

DRAFT PRELIMINARY ENGINEERING REPORT

Florida Department of Transportation

District One

SR 865 (San Carlos Blvd.)

Limits of Project: From North of Crescent Street to North of Hurricane Pass Bridge

Lee County, Florida

Financial Management Number: 433726-2-32-01

ETDM Number: 14124

Date: January 2022

The environmental review, consultation, and other actions required by applicable federal environmental laws for this project are being, or have been, carried out by FDOT pursuant to 23 U.S.C. § 327 and a Memorandum of Understanding dated December 14, 2016 and executed by FHWA and FDOT.

# PROFESSIONAL ENGINEER CERTIFICATION

## PRELIMINARY ENGINEERING REPORT

**Project:** SR 865 (San Carlos Boulevard) from North of Crescent Street to North of Hurricane Pass Bridge

**ETDM Number:** 14124

**Financial Project ID:** 433726-2-32-01

**Federal Aid Project Number:** D119-051-B

This preliminary engineering report contains engineering information that fulfills the purpose and need for the SR 865 (San Carlos Boulevard) Project Development & Environment Study from North of Crescent Street to North of Hurricane Pass Bridge in Lee County, Florida. I acknowledge that the procedures and references used to develop the results contained in this report are standard to the professional practice of transportation engineering as applied through professional judgment and experience.

I hereby certify that I am a registered professional engineer in the State of Florida practicing with WGI, Inc., and that I have prepared or approved the evaluation, findings, opinions, conclusions, or technical advice for this project.

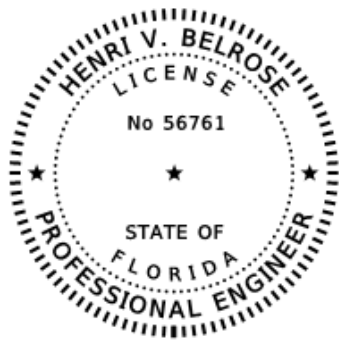

This item has been digitally signed and sealed by Henri V. Belrose, P.E. on the date adjacent to the seal.

Printed copies of this document are not considered signed and sealed and the signature must be verified on any electronic copies.

# Table of Contents

<b>Table of Contents</b> .....	<b>i</b>
<b>Appendices</b> .....	<b>iv</b>
<b>List of Tables</b> .....	<b>iv</b>
<b>Table of Figures</b> .....	<b>iv</b>
<b>1.0 Project Summary</b> .....	<b>1-1</b>
1.1 Project Description.....	1-1
1.2 Purpose & Need .....	1-3
1.2.1 Capacity/Transportation Demand: Improve Operational Performance.....	1-3
1.2.2 Social and Economic Demand: Improve Access to Community Features.....	1-3
1.2.3 Modal Interrelationships: Enhance Mobility Options and Multi-Modal Access.....	1-4
1.2.4 Safety: Enhance Safety for Vehicular and Non-Vehicular Transportation.....	1-4
1.3 Commitments .....	1-4
1.4 Alternatives Analysis Summary.....	1-4
1.5 Description of Preferred Alternative .....	1-4
1.6 List of Technical Documents .....	1-5
<b>2.0 Existing Conditions</b> .....	<b>2-1</b>
2.1 Roadway.....	2-1
2.2 Right-of-Way .....	2-1
2.3 Roadway Classification & Context Classification .....	2-1
2.4 Adjacent Land Use .....	2-2
2.5 Access Management Classification .....	2-2
2.6 Design and Posted Speeds .....	2-2
2.7 Vertical and Horizontal Alignment.....	2-3
2.8 Pedestrian Accommodations .....	2-4
2.9 Bicycle Facilities .....	2-4
2.10 Transit Facilities .....	2-5
2.11 Pavement Condition .....	2-5
2.12 Traffic Volumes and Operational Conditions.....	2-6
2.13 Intersection Layout and Traffic Control .....	2-6
2.14 Railroads.....	2-6
2.15 Crash Data and Safety Analysis .....	2-6

2.16	Drainage .....	2-7
2.17	Soils and Geotechnical Data.....	2-7
2.18	Utilities .....	2-7
2.19	Lighting.....	2-7
2.20	Signs .....	2-8
2.21	Aesthetic Features .....	2-8
2.22	Bridges and Structures.....	2-9
<b>3.0</b>	<b>Project Design Controls &amp; Criteria.....</b>	<b>3-1</b>
3.1	Roadway Context Classification .....	3-1
3.2	Design Control and Criteria.....	3-1
<b>4.0</b>	<b>Alternatives Analysis.....</b>	<b>4-1</b>
4.1	Previous Planning Studies .....	4-1
4.2	No-Build (No-Action) Alternative.....	4-1
4.3	Transportation Systems Management and Operations Alternative (TSM&O).....	4-2
4.4	Future Conditions.....	4-3
4.5	Build Alternative(s) .....	4-4
4.6	Comparative Alternatives Evaluation .....	4-4
4.7	Selection of the Preferred Alternative.....	4-6
<b>5.0</b>	<b>Project Coordination &amp; Public Involvement .....</b>	<b>5-1</b>
5.1	Agency Coordination.....	5-1
5.2	Public Involvement.....	5-1
<b>6.0</b>	<b>Design Features of the Preferred Alternative .....</b>	<b>6-1</b>
6.1	Engineering Details of the Preferred Alternative.....	6-1
6.1.1	Typical Sections.....	6-2
6.1.2	Bridges and Structures.....	6-4
6.1.3	Right-of-Way and Relocations .....	6-5
6.1.4	Horizontal and Vertical Geometry .....	6-5
6.1.5	Bicycle and Pedestrian Accommodations .....	6-5
6.1.6	Multi-Modal Accommodations.....	6-6
6.1.7	Access Management .....	6-6
6.1.8	Intersection and Interchange Concepts.....	6-6
6.1.9	Intelligent Transportation System and TSMO Strategies.....	6-6
6.1.10	Utilities.....	6-7

6.1.11	Drainage and Stormwater Management Facilities .....	6-8
6.1.12	Floodplain Analysis.....	6-9
6.1.13	Transportation Management Plan.....	6-10
6.1.14	Special Features .....	6-11
6.1.15	Design Variations and Design Exceptions .....	6-11
6.1.16	Cost Estimates.....	6-13
6.2	Summary of Environmental Impacts of the Preferred Alternative.....	6-13
6.2.1	Land Uses .....	6-13
6.2.2	Section 4(f).....	6-14
6.2.3	Cultural Resources .....	6-20
6.2.4	Wetlands .....	6-22
6.2.5	Protected Species and Habitat.....	6-22
6.2.6	Essential Fish Habitat .....	6-24
6.2.7	Highway Traffic Noise .....	6-25
6.2.8	Contamination .....	6-27

# Appendices

- Appendix A: Concept Roll Plots
- Appendix B: Construction Cost Estimate
- Appendix C: Draft Typical Section Package

## List of Tables

Table 1: Existing Horizontal Curve Data .....	2-3
Table 2: Recommended 2015 AADT and VPD for Peak Season .....	2-6
Table 3: Projected Average Daily Traffic by Year and Day of Week .....	2-6
Table 4: Design Criteria .....	3-2
Table 5: Alternatives Comparison Matrix .....	4-5

## Table of Figures

Figure 1: Project Location Map .....	1-2
Figure 2: Paint Color for Matanzas Pass Bridge .....	2-8
Figure 3: Painted/textured pavement for Times Square Mall and Fifth Street intersection.....	2-8
Figure 4: Beach Alternative 1 .....	4-7
Figure 5: Island Alternative 2 .....	4-8
Figure 6: Lee County's Seafarer's Alternative .....	4-9
Figure 7: Proposed Typical Section – Matanzas Pass Bridge .....	6-2
Figure 8: Proposed Typical Section – Main Street to Hurricane Pass Bridge.....	6-3
Figure 9: Proposed Typical Section – Hurricane Pass Bridge .....	6-3
Figure 10: Coastal Construction Line Location Map .....	6-11

## 1.0 Project Summary

### 1.1 Project Description

The Florida Department of Transportation (FDOT) District One is conducting a Project Development and Environment (PD&E) Study to evaluate and document proposed improvements along Estero Boulevard and San Carlos Boulevard (SR 865). The limits of the improvements are from north of Crescent Street to north of Hurricane Pass Bridge (also known as Hurricane Bay Bridge), in Lee County. In partnership with Lee County, LeeTran, and the Town of Fort Myers Beach, this project incorporates Lee County's Seafarers Alternative along Estero Boulevard from Crescent Street to Fifth Street. The total project length is approximately 1.2 miles.

Within the project's design plans, the Matanzas Pass Bridge will be modified to accommodate a shared-use path along the east side of the bridge. The existing southbound Bus/Bicycle-Only lane will be converted to a general use travel lane. San Carlos Boulevard from Main Street to Hurricane Bay Bridge will be restriped to accommodate bicycle lanes in each direction of travel. The existing southbound Right-Turn-Only lane approaching Main Street will be converted to a general use travel lane that will continue across the Matanzas Pass Bridge. A new traffic signal will be constructed at Main Street. The alternating signal at Prescott Street / Buttonwood Drive will be adjusted to operate as a conventional signal. The Hurricane Bay Bridge will be modified to accommodate bicycle lanes in each direction of travel and a barrier-protected sidewalk along the west side of the bridge.

The proposed improvements include adding bus bays in the eastbound (EB) and westbound (WB) directions between Crescent Street and Fifth Street; the reconfiguration of lanes along the Matanzas Pass Bridge to accommodate a new shared-use path along the west side of the bridge and restriping to include two southbound lanes and one northbound lane; new signals and modification to existing traffic signals and crosswalks, adding a bus bay on the southbound (SB) side of SR 865 (San Carlos Boulevard) south of the Main Street intersection and restriping the Hurricane Pass Bridge to accommodate bicycle lanes in each direction of travel and a barrier-separated shared use path along the west side of the bridge. The project will also include signing and pavement marking, installation of roadway lighting and intelligent transportation systems (ITS), and minor landscaping activities. The project was evaluated through FDOT's Efficient Transportation Decision Making (ETDM) process as project #14124.

In partnership with Lee County, LeeTran, and Town of Fort Myers Beach, the updated project design will incorporate Lee County's Seafarer's Alternative at the intersection of Estero Boulevard and Fifth Street. New traffic signals will be constructed at Fifth Street to replace the existing pedestrian crosswalk signals south of Fifth Street. Detailed descriptions of the alternatives considered, including the preferred alternative are provided in Section 4.0.





	<h3>Project Location Map</h3> <p>SR 865 (San Carlos Boulevard) from North of Crescent Street to North of Hurricane Pass Bridge</p> <p>FPID: 443726-2-32-01</p> <p>Lee County, Florida</p>	 Project Limits
	<small>Maps are for graphical purposes only. They do not represent a legal survey. While every effort has been made to ensure that these data are accurate and reliable within the limits of the process, WGI cannot assume liability for any damages caused by any errors or omissions in the data. WGI makes no warranty, expressed or implied, nor does the fact of distribution constitute such a warranty.</small>	<small>Map prepared by WGI, December 10, 2021 Data Source: Project limits provided by WGI, Basemap provided by ESRI Online Services.</small>

Figure 1: Project Location Map



## 1.2 Purpose & Need

The primary purpose of the SR 865 (San Carlos Boulevard) mobility improvement project is to provide additional travel options on a congested corridor, especially during the peak tourist season (January - April). The proposed project is also intended to promote emphasis for alternative transportation use and increase public transit ridership. The project will also enhance mobility and safety for vehicular and non-vehicular transportation and increase accessibility and connections between community points of interest. The need for the project is based on the following criteria:

### 1.2.1 Capacity/Transportation Demand: Improve Operational Performance

The project is expected to help relieve congestion caused by high traffic volumes accessing Fort Myers Beach and other community destinations, especially during peak season timeframes, by improving mobility and enhancing alternative modes of transportation. In 2013, the peak season weekday average daily traffic (PSWADT) for the project corridor was 25,397, and the corridor had a Level of Service (LOS) of "D". By year 2035, the project corridor is anticipated to reach a PSWADT of 31,011, surpassing the 29,000 AADT maximum level of capacity. It should be noted that the 2035 volume was anticipated with a mere 1% growth rate. Should that rate increase in the future, the traffic volume of the corridor would certainly exceed capacity.

While the posted speed limit on SR 865 (San Carlos Boulevard) within the proposed project limits ranges from 35 mph to 45 mph, the average speed within the corridor is around 12.9 mph. Existing average travel time comparisons in the corridor:

- Automobile (northbound) - 6.3 minutes
- Automobile (southbound) - 18.3 minutes
- Trolley (northbound) - 12.4 minutes
- Trolley (southbound) - 23.3 minutes

Additionally, an average of three to four public transit vehicles travel the corridor per hour with average midday headway times around 16.7 minutes. Each public transit vehicle can accommodate 32 seated and 23 standees (total 55 riders.) With the additional mobility improvements in the corridor, public transit could run more frequently per hour with reduced wait times.

### 1.2.2 Social and Economic Demand: Improve Access to Community Features

The mobility improvement project will enhance economic viability in the area by moving people more quickly and conveniently and with additional transportation options from the mainland to businesses and recreation opportunities around Fort Myers Beach. Community facilities in Fort Myers Beach include the American Legion - Post 274, Loyal Order of Moose Lodges, Compass Rose Boat Club, Estero Island Beach Accesses, and Fort Myers Beach Chamber of Commerce.

### 1.2.3 Modal Interrelationships: Enhance Mobility Options and Multi-Modal Access

SR 865 (San Carlos Boulevard) is identified as a primary pedestrian/bicycle corridor in the Lee County Bicycle Pedestrian Master Plan. This project identifies opportunities for new and improved bicycle and pedestrian facilities.

There are no existing dedicated bike lanes along SR 865, except on the Matanzas Bridge in the shared bus lane. Sidewalks are currently present on both sides of SR 865 (San Carlos Boulevard) from CR 869 (Summerlin Rd.) to Main Street. From Main Street to Estero Boulevard, sidewalks are limited to a pathway on the east side of the roadway separated from vehicular traffic by a low barrier wall. The proposed project will allow for better overall multi-modal access to retail, employment, and residences in the area.

### 1.2.4 Safety: Enhance Safety for Vehicular and Non-Vehicular Transportation

The SR 865 (San Carlos Boulevard) mobility improvements project will enhance safety for both vehicular and non-vehicular modes of transportation by identifying potential improvements at key intersections along the corridor with features such as roundabouts, improved signalization, and operational improvements. In 2010, there was one fatal crash within the 200' buffer of the project corridor and 36 nonfatal crashes. The corridor has a safety ratio of 1.36 (meaning that there are on average more crashes on this corridor than the State average for a similar facility type.)

## 1.3 Commitments

The FDOT will coordinate further with Lee County Parks and Recreation for the removal and relocation/replacement of existing park signage, landscaping, and sprinkler irrigation systems within the impacted area along the northern edge of the Crescent Beach Family Park.

Based on the use of Consultation Key couplet 12b to reach a MANLAA-Programmatic effect determination, the FDOT commits to implementing Florida Bonneted Bat BMPs 1, 3, 4 and 5 for this project.

## 1.4 Alternatives Analysis Summary

An *Operational Analysis Report* (OAR) was prepared in December 2018 to document and summarize the analysis of the traffic operations and develop feasible improvements for SR 865. Within the OAR, six build alternatives were evaluated. Of these, four were Beach Alternatives that included work within the Town of Fort Myers on Estero Island and the Matanzas Pass Bridge. Two were Island Alternatives which included work on San Carlos Island and improvements to Hurricane Pass Bridge.

Refer to Section 5 of the December 2018 OAR included in the FDOT SWEPT project file.

## 1.5 Description of Preferred Alternative

Several build alternatives were presented at a public meeting in February 2018. As a result, Beach Alternative 1 and Island Alternative 2 were recommended for design along the San Carlos Boulevard corridor from Estero Boulevard to north of Hurricane Pass Bridge.

Refer to Section 7 of the December 2018 OAR.

## 1.6 List of Technical Documents

- ETDM #14124 Programming Screen Summary Report, April 2015
- Project Traffic Report, July 2018
- Operational Analysis Report, December 2018
- Community Awareness Program, July 2019
- Pavement Survey and Evaluation Report, February 2020
- Contamination Screening Evaluation Report, March 2020; Revised January 2021
- Cultural Resource Assessment Survey, March 2020
- Addendum to the Cultural Resource Assessment Survey, October 2020
- Bridge Development Report – Matanzas Pass Bridge (#120088), May 2020
- Bridge Technical Memorandum – Hurricane Pass Bridge (#120089), May 2020
- Drainage Design Documentation, May 2020
- Drainage Documentation for the Intersection Improvements for SR 865, December 2020
- Natural Resources Evaluation Report, December 2020
- Preliminary Geotechnical Roadway Report, December 2020
- Water Quality Impact Evaluation, January 2021
- Noise Study Report – March 2021
- Section 4(f) Documentation, Date TBD
- Public hearing Transcript/Certification, Date TBD
- Comments and Coordination Report, Date TBD

## 2.0 Existing Conditions

### 2.1 Roadway

Within the project limits, Estero Boulevard from Crescent Street to the intersection at Fifth Street is a two-lane undivided roadway. From Estero Boulevard to Main Street, San Carlos Boulevard is primarily an elevated two-lane undivided urban minor arterial roadway with a dedicated southbound Bus/Bicycle-Only lane and a barrier-protected sidewalk on the east side of the bridge. From Main Street to north of Hurricane Pass Bridge, the roadway transitions to a four-lane divided minor arterial roadway with a two-way left-turn lane median and sidewalks on both sides of the roadway.

Refer to Section 2.1 of the December 2018 OAR.

### 2.2 Right-of-Way

The right-of-way (ROW) limits for this project are as follows:

- Estero Boulevard is centered within a typical 50'-60' ROW from Crescent Street to Fifth Street.
- SR 865 is centered within a typical 80'-85' ROW from Fifth Street to Matanzas Pass Bridge.
- Matanzas Pass Bridge has a 200' existing sovereign submerged lands easement for the main navigation channel.
- SR 865 is centered with an 80'-100' ROW from Matanzas Pass Bridge to Hurricane Pass Bridge.

For more details on ROW, refer to Appendix A, Concept Roll Plots.

### 2.3 Roadway Classification & Context Classification

SR 865 is an urban minor arterial within the study limits. Its context classification is Urban General (C4) from north of Crescent Street to Main Street and Suburban Commercial (C3C) from Main Street to north of Hurricane Pass Bridge.

Refer to Section 2.1.1 of the December 2018 OAR included.

## 2.4 Adjacent Land Use

Existing and future land uses were reviewed within the study area. Existing landward uses along the project corridor (and their approximate percentages) consist of: Commercial and Services (35.1%), Fixed Single-Family Units (11.8%), Mobile Home Units (11%), Marinas and Fish Camps (7.5%), Multiple Dwelling Units/High Rise (2.6%) and Roads and Highways (2.24%). Waterward of these areas, Bays and Estuaries (27.1%) and Mangrove Swamps (4.2%) occupy much of the project study area. Within the Estero Island portion, the Town of Fort Myers Beach Future Land Use Map (revised 1999) shows Low Density Residential, Mixed Residential, Boulevard, Pedestrian Commercial, Marina, Recreation, Wetlands and Tidal Water uses within and adjacent to the project area. Within the San Carlos Island and mainland portions, the Lee County Comprehensive Plan's (LeePlan) Future Land Use Map (dated June 2020) shows Industrial, Urban Community, Suburban, Public Facilities, with minor portions of Open Lands and Conservation Lands within and adjacent to the project area.

This project is consistent with the Transportation Element and Future Land Use Element of the Town of Fort Myers Beach Comprehensive Plan (as amended November 2009) and LeePlan Future Land Use Element Chapter II and Transportation Element 4 Chapter III (as amended through June 2020). As discussed previously in Section 1.3, this project is included in the Lee County MPO's 2045 LRTP Cost Feasible Plan and FY 2020/21 - FY 2024/25 TIP and FDOT's current 2021-2024 STIP.

The proposed project will continue to support the existing and future land uses within the project and surrounding areas. Significant land use changes are not anticipated to occur along the project corridor if the proposed project is implemented.

## 2.5 Access Management Classification

SR 865 is Access Class 4 from north of Crescent Street to Main Street and Access Class 7 from Main Street to north of Hurricane Pass Bridge.

Refer to Section 2.1.2 of the December 2018 OAR.

## 2.6 Design and Posted Speeds

The posted speed on SR 865 from the beginning of the study to approximately 350 feet north of Fifth Street is 25 mph. From north of Fifth Street to Main Street (over the Matanzas Pass Bridge) it increases to 35 mph. From Main Street to the end of the study, it is 45 mph.

Refer to Section 2.1.3 of the December 2018 OAR.

## 2.7 Vertical and Horizontal Alignment

SR 865 from Crescent Street to Fifth Street is primarily an east-west route with one curve turning to the northeast direction. SR 865 from Fifth Street to Prescott Street is a straight tangent oriented in the north-northeast direction. Along Hurricane Pass Bridge, the alignment curves to the north and remains a north-south corridor to the end of the project. The existing horizontal curve data is shown in Table 1 below.

Table 1: Existing Horizontal Curve Data

PC	PT	Degree of Curvature	Radius (ft.)	Exist. Curve Length (ft.)
<b>SR 865 (San Carlos Boulevard)</b>				
MP = 0.182	MP = 0.316	2° 00' 00"	2864.79	711.65
MP = 0.438	MP = 0.525	0° 30' 00"	11459.16	456.00
MP = 0.998	MP = 1.091	4° 00' 00"	1432.39	386.31

As-built plans are not available for determining the vertical alignment of SR 865 off the bridges. Based on field observation, the general terrain (off-bridge) is level with no excessive grades or vertical curvature to restrict stopping sight distance.

Over the Matanzas Pass Bridge, the bridge transitions from a full superelevation at 2.8% to a normal crown over Matanzas Pass, then back to a full superelevation of -2.8%. The slope of the lower station grade line is +6.0% and the slope of the higher station grade line is -6.0%; the vertical curve length is 800'.

Refer to Section 3.6 of the May 2020 *Bridge Development Report (BDR) for Matanzas Pass Bridge (#120088)* included in the FDOT SWEPT project file.

Over Hurricane Pass Bridge, the bridge transitions from a normal crown to a full superelevation at 2%. The slope of the lower station grade line is +1.0% and the slope of the higher station grade line is -1.0%; the vertical curve length is 300'.

Refer to Appendix I of the May 2020 *Bridge Technical Memorandum (BTM) for Hurricane Pass Bridge (#120088)* included in the FDOT SWEPT project file.

## 2.8 Pedestrian Accommodations

Sidewalks are available from Summerlin Rd. to north of the Hurricane Pass Bridge on both sides of the road with a pedestrian crossing prior to the bridge to divert pedestrians to the eastern side of the roadway. The sidewalk resumes on both sides after from Prescott Street/Buttwood Drive to Main Street, where the sidewalk on the western side ends and the eastern side carries over Matanzas Pass Bridge where, at the base of the bridge, sidewalks are available on both sides.

Due to the existing 6% slope of the Matanzas Pass Bridge, the structure is not currently compliant with ADA standards. As discussed in the Matanzas Pass Final Bridge Development Report (dated May 2020), the 8-foot shared use path proposed along the west side of the Matanzas Pass Bridge was reviewed for consistency with ADA requirements. These requirements include the evaluation of spacing and dimensions for landings, as well as providing a Latex Modified Concrete layer to existing deck surface. The potential implementation of these considerations resulted in impacts to bridge load rating and the function/location of bridge drainage features and disproportionate project cost impacts. As a result, a Design Variation was prepared to demonstrate that it is structurally impracticable to meet Americans with Disabilities Act (ADA) requirements (as described within 28 CFR Part 35, subsection 35.151) for this portion of the project. However, ADA requirements have been incorporated into the project design elsewhere within the project, as necessary.

Although the project limits are within the Estero-Bonita Corridor of the SUN Trail network (the statewide system of high-priority (strategic) paved trail corridors for bicyclists and pedestrians), as part of the Section 4(f) coordination for this project, Lee County's Deputy County Manager has confirmed that this feature is not currently a significant resource in meeting the recreational, park and trail objectives of Lee County and Fort Myers Beach.

Refer to Section 4.3 of the December 2018 OAR.

## 2.9 Bicycle Facilities

Bicycle lanes are only available on the SB shoulder of the Matanzas Pass Bridge as they are part of a sharrow with the dedicated trolley lane. Only a paved shoulder is provided along the NB lanes on Matanzas Pass Bridge. Along the Matanzas Pass Bridge NB sidewalk, bicyclists are instructed by signage to walk their bikes over the bridge on the sidewalk.

Refer to Section 4.3 of the December 2018 OAR.

## 2.10 Transit Facilities

Transit service is provided throughout the project. LeeTran Route 400 (Beach Park & Ride/Lovers Key) has several stops within the project limits. There is also an existing Park-N-Ride facility in the southwest quadrant of the SR 865/Main Street intersection. The project design plans do not show impacts at these facilities. Along Estero Boulevard, bus bays will be added in the EB and WB directions between Crescent Street and Fifth Street. Another bus bay will be added on the SB side of SR 865 south of the Main Street intersection. Passport, LeeTran's paratransit provider, services the project limits as an advanced reservation, origin-to-destination service for persons with disabilities who are unable to use the regular fixed-route public transit service due to their disability. Passport is designed to meet the ADA service criteria established by the federal government. Through the implementation of a maintenance of traffic (MOT) plan and the FDOT's Standard Specifications for Road and Bridge Construction, adverse impacts to local transit resources/providers are not anticipated.

Refer to Section 4.4 of the December 2018 OAR.

## 2.11 Pavement Condition

The pavement has a dense-graded friction course. The overall condition of this section is fair to poor with top-down cracks primarily ranging from light to medium cracks.

Refer to the February 2020 *Pavement Survey and Evaluation Report* included in the FDOT SWEPT project file.



## 2.12 Traffic Volumes and Operational Conditions

The July 2018 *Project Traffic Report (PTR)* documents existing conditions and the traffic analysis findings.

Refer to Section 3.1 and 3.4 of the December 2018 OAR.

Table 2: Recommended 2015 AADT and VPD for Peak Season

Roadway	From	To	Rec. AADT	Peak Season VPD	
			2015	Mon-Thur	Fri & Sat
Estero Blvd	Fifth St	Crescent St	17,900	20,900	21,900
SR 865	Main St	Fifth St	21,500	25,100	26,400
SR 865	Prescott St	Main St	22,700	26,500	27,800
SR 865	RV Park	Prescott St	25,300	29,600	31,000

Table 3: Projected Average Daily Traffic by Year and Day of Week

Roadway	From	To	2020			2040		
			ADT	Peak Season VPD		ADT	Peak Season VPD	
				Mon-Thur	Fri & Sat		Mon-Thur	Fri & Sat
Estero Blvd	Fifth St	Crescent St	18,000	21,000	22,100	18,500	21,600	22,700
SR 865	Main St	Fifth St	22,100	25,800	27,100	24,600	28,800	30,200
SR 865	Prescott St	Main St	23,400	27,300	28,700	26,400	30,900	32,400
SR 865	RV Park	Prescott St	25,900	30,300	31,800	29,000	33,900	35,600

## 2.13 Intersection Layout and Traffic Control

A signalized intersection is present at SR 865 (San Carlos Boulevard) and Prescott Street/Buttonwood Drive. This signal operates as an alternating signal allowing only one through lane at a time. Prescott Street/Buttonwood Drive has pedestrian crosswalk features on the south and east legs of the intersection. There are signalized pedestrian crossings north of Hurricane Pass Bridge and at Estero Boulevard from the Margaritaville Ft. Myers development site to Times Square shopping mall. All other intersections along SR 865 are unsignalized two-way stop controlled with stop signs on the minor crossing streets.

## 2.14 Railroads

There are no railroads in the vicinity of the project study area.

## 2.15 Crash Data and Safety Analysis

The City of Fort Myers Beach ranks in the top 25 percent of cities of comparable size by population in 1) Fatalities & Injuries, 2) Impaired Drivers, 3) Bicycle Related, 4) Motorcycle Related and 5) Pedestrian Related crash categories. Based on the crash data analysis, high crash rates were noted at the intersections of SR 865/Main Street and SR 865/Prescott Street/Buttonwood Drive.

Refer to Section 2.3 of the December 2018 OAR.

## 2.16 Drainage

Much of the existing stormwater management system is comprised of closed storm drain systems that collect and convey roadway runoff through a network of pipes, eventually flowing to Matanzas Pass or to a permitted stormwater pond (wet detention Pond 1) located east of San Carlos Boulevard just off Buttonwood Drive. The Matanzas Pass Bridge is drained by a combination of scuppers and barrier wall slots over the Matanzas Pass waterway and bridge deck inlets for all bridge spans located over existing roadways. The water from the existing deck inlets is routed through the existing pier columns and into the existing storm water system that ultimately discharges to Matanzas Pass. The Hurricane Pass Bridge drains runoff off the bridge towards and into roadway inlets adjacent to both ends of the bridge.

Refer to the “Existing Conditions” Section of the May 2020 *Drainage Design Documentation* included in the FDOT SWEPT project file.

## 2.17 Soils and Geotechnical Data

A preliminary subsurface soil exploration program for the subject project has been completed. Based on the Web Soil Survey, as prepared by the U.S. Department of Agriculture Natural Resources Conservation Service (NRCS), two soil types are present within the roadway project limits. Soil at this site consists of NRCS Soil Map Unit #7 – Matlacha gravelly fine sand-Urban land complex, 0-2 percent slopes and #59 – Urban Land, 0 to 2 percent slopes. The setting for this soil consists of hills, ridges, knolls, rises, and flatwoods on marine terraces. No information regarding permeability, drainage, or depth of normal seasonal high-water table was provided in the Web Soil Survey Report.

Refer to the December 2020 *Preliminary Geotechnical Roadway Report* included in the FDOT SWEPT project file.

## 2.18 Utilities

Utility identification was conducted with the use of as-built plans, field reconnaissance and Sunshine 811. Quality Level B designation of underground utilities will take place during final design. Potential locations of underground utility conflicts will be confirmed with Quality Level A test hole investigation during final design.

Roadway lighting is provided by internal conduits located within each concrete barrier and an external ITS/fiber conduit runs longitudinally along the east overhang of the bridge. However, existing sub-aqueous utilities have been identified in the vicinity to the western limits of the existing Matanzas Pass Bridge. All located utilities and applicable Utility Agent Owners (UAOs) are listed below:

- 20” HDPE Force Main – Lee County Utilities
- Gas Line – TECO Peoples Gas
- 18” HDPE Water Main – Town of Fort Myers Beach
- High Voltage Cable – Florida Power & Light (FPL)
- Fiber Optic Cable – Comcast, Century Link and Summit Broadband

## 2.19 Lighting

The SR 865 lighting system consists of single tubular upsweep arms and upsweep arms bolted onto existing electrical poles. The SR 865 lighting system is built out throughout the corridor.

Refer to Section 2.4 of the December 2018 OAR.

## 2.20 Signs

Signage along SR 865 (San Carlos Boulevard) within the project area is predominately made up of single-post, ground-mounted and bridge-mounted signs. There is two multi-post, ground-mounted sign at the Prescott Street/Buttonwood Drive intersection. There are two overhead sign structures between the Prescott Street/Buttonwood Drive intersection and Main Street and one at the north end of Hurricane Pass Bridge.

## 2.21 Aesthetic Features

Aesthetic features along SR 865 include gateway signage for San Carlos Island and Fort Myers Beach, blue paint selected for Matanzas Pass Bridge and retaining walls (Figure 2) and painted/textured pavement and sidewalks for Times Square Shopping Mall and pedestrian refuge islands (Figure 3).



*Figure 2: Paint Color for Matanzas Pass Bridge*



*Figure 3: Painted/textured pavement for Times Square Mall and Fifth Street intersection*

## 2.22 Bridges and Structures

There are two existing bridges along SR 865 within the limits of the study area: Matanzas Pass Bridge and Hurricane Pass Bridge.

The original SR 865 (San Carlos) Bridge (Structure No. 120088) over Matanzas Pass was constructed in 1980. Beyond typical maintenance improvements, the existing structure has not undergone any significant retrofits or operational improvements. Based on the bridge inspection report conducted by the Florida Department of Transportation in February 2018 the existing structure is in good condition. The bridge NBI Sufficiency Rating was 84. The Health Index was 38.58.

The existing typical section for the Matanzas Pass structure is comprised of one 11'-0" SB lane, one 11'-0" NB lane, a 12'-0" outside shoulder / dedicated SB bus lane, a 6'-0" NB shoulder and a 5'-10" pedestrian walkway. The critical existing load rating for Bridge 120088 is 0.70 for Design Inventory (HL-93) due to Service III (inventory) and the Operating Rating is 1.04.

The SR 865 (San Carlos Boulevard) bridge (Structure No. 120089) over Hurricane Pass was originally constructed in 1980 with a total bridge length of 350' comprised of 10 – 35'-0" simple spans. The original structure had a navigable clear width of 32'-0", a minimum vertical clearance of 6.02' and an overall bridge width of 49'-4". The original superstructure consists of 1'-6" deep voided concrete precast panels topped with a 2" minimum wearing surface. The original cast-in-place substructure consists of two end bents and 9 intermediate bents. All substructures are supported by a combination of plumb and battered 18" prestressed concrete piles.

In 1990, the Hurricane Pass Bridge was widened to the west 15'-9.5" and to the east 22'-0" to reach the current overall bridge width of 83'-0.5". All portions of the widened superstructure consist of 1'-6" cast-in-place concrete slabs, doveled into the original voided concrete precast panels.

The latest inspection report, dated April 2018, classifies the existing structure as scour critical. However, previously installed scour countermeasures (articulating concrete blocks) have been installed on the channel bottom from intermediate bent 5 through bent 9. The inspection report also lists the existing structure's NBI sufficiency rating of 81 and health index of 98.52.

Refer to *Bridge Development Report – Matanzas Pass Bridge (#120088)* and *Bridge Technical Memorandum – Hurricane Pass Bridge (#120089)*.

## 3.0 Project Design Controls & Criteria

### 3.1 Roadway Context Classification

SR 865 is an urban minor arterial within the study limits. Its context classification is Urban General (C4) from the north of Crescent Street to Main Street and Suburban Commercial (C3C) from Main Street to north of Hurricane Pass Bridge.

Refer to Section 2.1.1 of the December 2018 OAR.

### 3.2 Design Control and Criteria

Project limits are made up of SR 865 (San Carlos Boulevard) and Estero Boulevard. The project limits on Estero Boulevard are from Crescent Street to Fifth Street and maintained by Lee County. SR 865 (San Carlos Boulevard) begins at Fifth Street and is maintained by the Florida Department of Transportation (FDOT).

Applicable design criteria for San Carlos Boulevard come from:

- *FDOT Design Manual (FDM) 2021*
- *Standard Plans for Road and Bridge Construction - FY 2021-22*
- *FDOT Structures Manual 2021*
- *FDOT Drainage Manual 2021*

Applicable design criteria for Estero Boulevard come from:

- *FDOT Manual of Uniform Minimum Standards for Design, Construction and Maintenance for Streets and Highways (aka Florida Greenbook (FGB)) 2018.*

Table 4: Design Criteria

Design Element		SR 865 from north of Fifth Street to Main Street	SR 865 from Main Street to north of Hurricane Pass Bridge	Source
General	Access Management	4	7	
	Context Classification	C4	C3C	Context Classification Memo
	Control Vehicle	WB-62FL	WB-62FL	FDM 201.6.2
	Design Period	20 years	20 years	FDM 201.3
	Design Speed	35 mph	40 mph	FDM Table 201.5.1
	Design Vehicle	WB-40	WB-40	FDM 201.6
	Functional Classification	Urban Minor Arterial	Urban Minor Arterial	FDOT Straight Line Diagram
	Posted Speed	35 mph	40 mph	
Typical Section	Number of Lanes			
	Lane Width	10' min.	11' min.	FDM Table 210.2.1
	TWLTW Width	11'	12'	FDM Table 210.2.1
	Median Width	15.5'	22'	FDM Table 210.3.1
	Bicycle Lane Width	5'	5'	FDM 223.2.1.1
	Border Width	12'	14'	FDM Table 210.7.1
	Lateral Offset	1.5'	4'	FDM Table 215.2.2
	Sidewalk Width	6'	6'	FDM Table 222.2.1.1
	ROW Width			Existing ROW maps
Horizontal	Min. Stopping Sight Distance	250'	305'	FDM Table 210.11.1
	Max. Deflection w/o Curve	2°	2°	FDM 210.8.1
	Min. Length of Curve	525'	600'	FDM Table 210.8.1
	Max. Curvature (Min. Radius)	14° 15'	10° 45'	FDM Table 210.9.2, FGB Table 3-12
	Max. Superelevation	0.05	0.05	FDM 210.9
Vertical	Max. Grade	7	7	FDM Table 210.10.1, note (1)
	Max. Change in Grade w/o VC	0.9	0.8	FDM Table 210.10.2
	Base Clearance above BCWE	1'	2'	FDM 210.10.3(2)(a)
	Min. Crest Curve K	47'	70'	FDM Table 210.10.3
	Min. Sag Curve K	49'	64'	FDM Table 210.10.3
	Vertical Clearance	16.5'	16.5'	FDM Table 260.6.1

## 4.0 Alternatives Analysis

### 4.1 Previous Planning Studies

The flow of traffic in the Town of Ft Myers Beach has been the subject of over thirty-three studies to analyze vehicular and pedestrian traffic over the past twenty years; these studies were initiated by local agencies or municipalities. The FDOT was asked by the Lee County Metropolitan Planning Organization (MPO) to engage stakeholders and identify needs along SR 865 including solutions to address traffic congestion, safety and mobility.

FDOT conducted an operational analysis study for various alternatives. These are summarized in the December 2018 *Operational Analysis Report*. The recommended alternatives from that report were incorporated into the PD&E study and this Preliminary Engineering Report.

Refer to Section 1.2 of the December 2018 OAR.

### 4.2 No-Build (No-Action) Alternative

The No-Build Alternative maintains the existing conditions along SR 865. The No-Build Alternative will remain a viable alternative throughout the PD&E Study. Signals at Estero Boulevard/Crescent Street and Estero Boulevard/Old San Carlos Boulevard will be constructed by local agencies and are considered existing conditions for the purpose of this PD&E study.

#### Advantages of the No-Build Alternative

- No right of way needed.
- No design, right of way, or construction costs.
- No delays to motorists or inconveniences to property owners along the project corridor during construction.
- No construction impacts to the natural, physical, and social environment.

#### Disadvantages of the No-Build Alternative

- Does not meet the purpose and need of the project.
- Incompatible with the Lee County MPO Long Range Transportation Plan.
- The risk of crashes involving pedestrians or bicyclists will increase over time as vehicular, pedestrian and bicycle traffic volume increases on SR 865.
- Does not foster multi-modal transportation options for the community.

### 4.3 Transportation Systems Management and Operations Alternative (TSM&O)

A variety of analyses and studies were performed to find ways to improve traffic flow on SR 865 (San Carlos Boulevard). The subjects of these studies include the following:

- Traffic Signal Warrants
  - Signal warrant analyses were conducted at intersections along the corridor to see if traffic volumes or pedestrian volumes were high enough to warrant additional traffic signals.
  - Traffic signals to be implemented by others are recommended at the intersection of Estero Boulevard and Crescent Street and at the intersection of Old San Carlos Boulevard and Estero Boulevard.
  - Signals to be implemented with this project are warranted at SR 865 and Main Street and at SR 865 and Fifth Street.
- Roundabouts
  - Preliminary operational issues with the roundabouts proved the efficacy of the screening tool and the roundabouts were dropped from progressing to Step 2 Roundabout Screening.
- Sidewalk & Bike Lane Analysis
  - This analysis concluded that the FDOT should evaluate and develop roadway typicals and infrastructure improvements to facilitate bike lanes and continuous sidewalks on both sides of the facility.
  - As part of this project, the existing side walk on the NB side of SR 865 from Fifth Street to Main Street will be widened to shared use path width, bike lanes will be added from Main Street to Hurricane Pass Bridge and sidewalk will be added to the SB side of SR 865 from Prescott Street/Buttonwood Drive over Hurricane Pass Bridge.
- Transit Analysis
  - Barring the development of a parking garage or significant surface parking, the transit system cannot have much more impact. The recommendation is to develop parking opportunities to enable transit utilization.
  - No additional parking is included as part of this project.
- Parking Garage and People Mover
  - The recommendation for a parking garage is contingent on its construction along the west side of SR 865 from Prescott Street/Buttonwood Drive to Main Street, as it is the best opportunity to influence drivers to make the decision to avoid the congestion going over the Matanzas Pass Bridge; other locations were identified as not economically feasible or too distant from the congestion to influence the decision to utilize the garage.
  - The conveyance of individuals from the parking garage to Fort Myers Beach using automated electric vehicles is recommended based on capacities, operation and maintenance, and general costs.
  - No additional parking is included as part of this project.
- Reversible Lanes
  - Reversible lanes would not prove effective to implement for day-to-day operation and thus is not recommended as an infrastructure improvement.



- Southbound Tolling
  - The FDOT has recommended not to implement a southbound toll lane based on current policy and analysis showing no impact to traffic congestion.
- Wayfinding Parking Availability
  - Parking trailblazing signage would provide an opportunity to influence vehicle movements along the corridor and influence individuals reaching the base of the bridge headed southbound to consider turning right as opposed to the predominant through movement; the increased utilization of the right lane would lead to increased throughput over the bridge.
  - No signage related to Wayfinding Parking Availability is included in this project.
- Pedestrian Movements at Fifth Street / Estero Boulevard
  - The pedestrian movements through the intersection warranted review with traffic operations to determine the feasibility of a High intensity Activated crossWaK (HAWK) pedestrian crossing beacon in conjunction with the existing pedestrian crossing to the south of the intersection.
  - Since the SR 865/Fifth Street intersection warrants a fully signalized intersection, a HAWK beacon will not be included as part of this project.
- Pedestrian Overpass at the Pedestrian Crossing
  - A pedestrian overpass is recommended from a safety perspective, however, based on calculations, the overpass is not considered a cost feasible solution for traffic congestion relief as the current at-grade crossing appears to have negligible impact on traffic flow.
  - A pedestrian overpass will not be included as part of this project

Refer to Section 4 of the December 2018 OAR.

#### 4.4 Future Conditions

The design year for this project is 2040 and the maximum 2040 AADT is 26,400. In addition, two standalone projects (Pine Ridge Road Intersection Improvements and SR 865 Resurfacing, Restoration, and Rehabilitation (RRR) from Hurricane Pass Bridge to Summerlin Road) were evaluated and recommended in the OAR for implementation outside of this project as funds become available.

Refer to Sections 3.2, 3.4 and 5.3 of the December 2018 OAR and the July 2018 *Project Traffic Report* included in the FDOT SWEPT project file.

Margaritaville Resort broke ground in August of 2021, northeast of the San Carlos Boulevard/Estero Boulevard intersection. The property is bounded by these two facilities as well as Fifth Street and Crescent Street.

#### 4.5 Build Alternative(s)

Six build alternatives were evaluated and documented in the December 2018 OAR. Of these, four Beach Alternatives were evaluated that included work within the Town of Fort Myers on Estero Island and the Matanzas Pass Bridge. Two Island Alternatives were evaluated which included work on San Carlos Island and improvements to Hurricane Pass Bridge.

These alternatives aim to meet the purpose and need of this project by improving mobility, enhancing alternate modes of transportation, and improving safety for vehicular and non-vehicular traffic along the corridor. The common elements of the alternatives include barrier separated shared use paths, sidewalks, bicycle lanes, turn lane modifications, additional traffic signals, and improved pedestrian crossings at signalized intersections.

Refer to Section 5.1 and Appendices I, J, K, L, M, and N of the December 2018 OAR.

#### 4.6 Comparative Alternatives Evaluation

Beach Alternative 1 is the recommended alternative due to its ability to incorporate the right turn as the drop lane, its minimal impact to the surrounding area and the major cost savings when compared to the other three alternatives.

The main difference between the Island Alternatives was the approach to access management on the corridor and the number of phases in the signal at SR 865 and Main Street. Island Alternative 1 proposed the replacement of the center two way left turn lane with a raised median barrier and the elimination of left turns on the predominant movement at Main Street. The alternative's access management was deemed desirable but not necessary to achieve the goals of this project due to the public opposition expressed in public involvement. Additionally, commercial operations in the area expressed concern with truck operations in the corridor. Island Alternative 2 is the recommended alternative due to its ability to minimize impact to existing operations while still achieving the desired operational goals.

An Alternative Comparison Matrix is included below in Table 5.

Refer to Section 5.2 of the December 2018 OAR.

Table 5: Alternatives Comparison Matrix

	No Build Alternative	Beach Alternatives			Island Alternatives	
		Alternative 1	Alternative 2	Alternative 3	Alternative 1	Alternative 2
<b>Potential Business and Residential Relocations</b>						
Number of Business Impacts (parcels)	0	0	0	0	0	0
Number of Business Relocations	0	0	0	0	0	0
Number of Residential Impacts (parcels)	0	0	0	0	0	0
Number of Residential Relocations	0	0	0	0	0	0
Number of Outdoor Advertising Sign Relocations	0	0	0	0	0	0
<b>Natural/Cultural/Physical Environmental Effects</b>						
Archaeological Sites (potential impacts - high, medium, or low)	N/A	none	none	none	none	none
Historical Sites (potential impacts - high, medium, or low)	N/A	Low	Low	Low	Low	Low
Number of Section 4(f) Sites	0	1	1	1	0	0
Number of Noise Sensitive Sites Impacted	0	0	0	0	5	5
Direct Wetland Impacts (acres)	0	0	0	0	0	0
Secondary Wetland Impacts (acres)	0	0	0	0	0	0
Surface Water Impacts (acres)	0	0	0	0	0	0
Floodplain Impacts (acres)	0	0	0	0	0	0
Threatened and Endangered Species (potential impacts - high, medium, or low)	N/A	Low	Low	Low	Low	Low
Number of Contaminated Sites (rated low, medium, or high for potential impacts)	N/A	4 low / 1 medium / 4 high	4 low / 1 medium / 4 high	4 low / 1 medium / 4 high	1 low / 3 high	1 low / 3 high
<b>Cost Estimates</b>						
Construction	\$0	\$1,452,846	\$1,745,528	\$1,888,625	\$3,636,516	\$3,544,671
Final Design (12% of Construction)	\$0	\$174,342	\$209,463	\$226,635	\$436,382	\$425,360
Construction Engineering Inspection (12% of Construction)	\$0	\$174,342	\$209,463	\$226,635	\$436,382	\$425,360
Right-of-Way	\$0	\$0	\$3,700,000	\$2,070,000	\$0	\$0
Wetland Mitigation	\$0	\$0	\$0	\$0	\$0	\$0
Total Estimated Costs	\$0	\$1,801,529	\$5,864,455	\$4,411,895	\$4,509,279	\$4,395,392

Note: This table does not include an evaluation of the Seafarers Alternative.

#### 4.7 Selection of the Preferred Alternative

All of the build alternatives were presented at a public workshop in February 2018 and as a result, Beach Alternative 1 and Island Alternative 2 were recommended for design along the San Carlos Boulevard corridor from north of Crescent Street to north of Hurricane Pass Bridge (See Figures 4 and 5).

Refer to Section 7 of the December 2018 OAR.

In partnership with Lee County, LeeTran, and Town of Fort Myers Beach, this project will also incorporate Lee County's Seafarer's Alternative (see Figure 4) at the intersection of Estero Boulevard and Fifth Street. Lee County presented Seafarer's Alternative to Fort Myers Beach Town Council on March 2, 2020. Town Council consensus was to move forward with Lee County's intersection concept. This concept will meet the purpose and need of this project by improving traffic operations and safety, increasing access to alternate modes of transportation and enhancing safety for pedestrians traversing the intersection.

As part of Seafarer's Alternative, new traffic signals will be constructed at Fifth Street to replace the existing pedestrian crosswalk signals. The posted speed limit will remain 25 mph. Associated with the reconfiguration of the SR 865 intersection at Estero Boulevard/Fifth Street, a new bus bay is proposed to service LeeTran Route 400 (Beach Park & Ride/Lovers Key). The reconstructed intersection will reinforce the purpose and need of this project by enhancing public transit mobility, pedestrian safety, and providing opportunity areas for landscaping and other aesthetic features.

Beach Alternative 1



Estero Blvd. Intersection and Matanzas Bridge

Beach Alternative 1

Figure 4: Beach Alternative 1

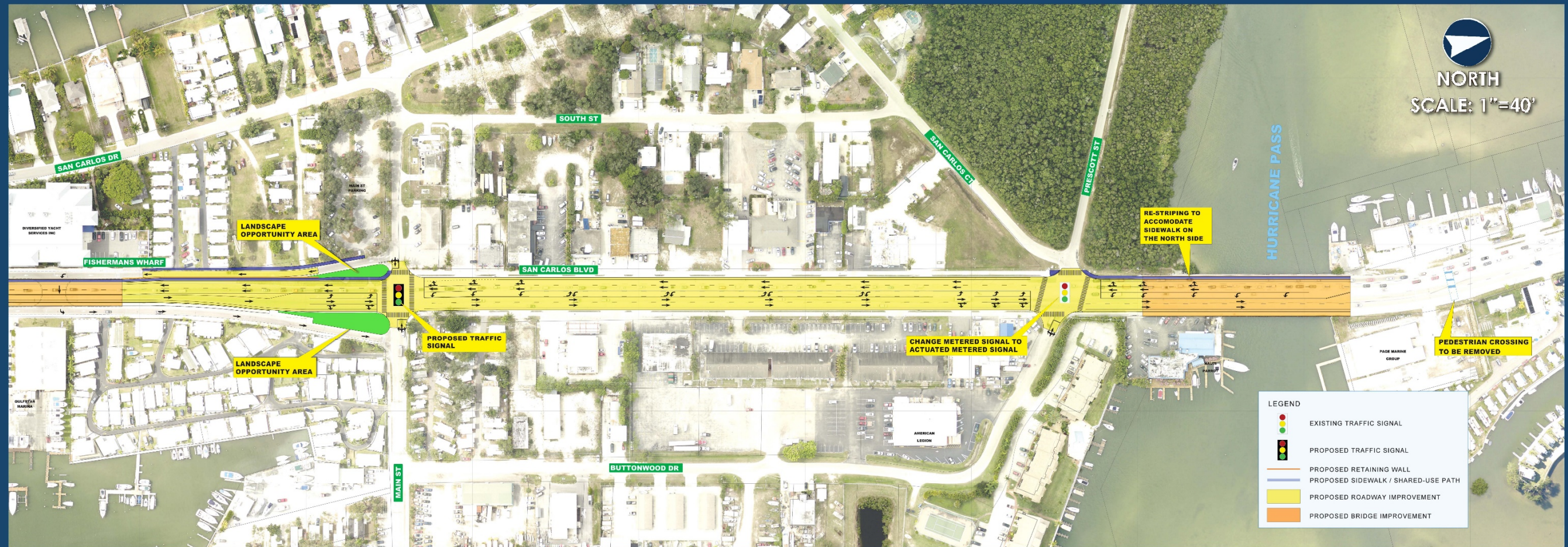

Main Street Intersection to Hurricane Pass Bridge

Island Alternative 2

Figure 5: Island Alternative 2

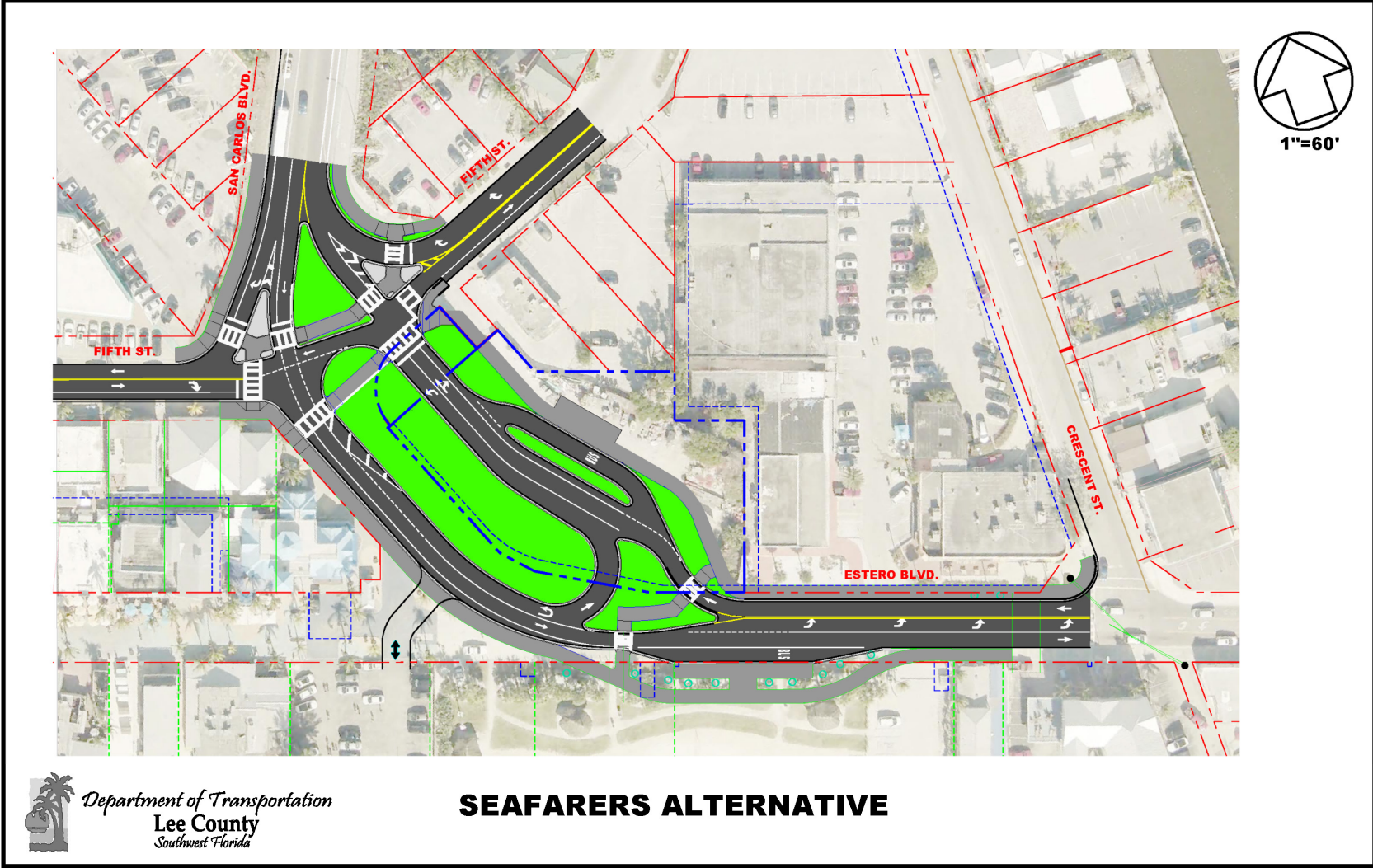

Figure 6: Lee County's Seafarer's Alternative

## 5.0 Project Coordination & Public Involvement

### 5.1 Agency Coordination

Through the ETDM process (project #14124), FDOT informed numerous federal, state, and local agencies of the project and its scope. The ETAT provided their comments on the project's purpose and need and issued their Degree of Effect (DOE) by resource area. Upon completion of the ETDM Programming Screen review, the *Programming Screen Summary Report* was developed and published on April 30, 2015 with FDOT's response to each DOE as well as discussion about the overall project. As a result of the ETDM screening, there were no substantial comments received.

Since 2015, fifteen (15) local stakeholder and agency coordination meetings were held with local government and key stakeholders which include: Lee County staff, Lee Metropolitan Planning Organization (MPO) and its committees, and the Town of Fort Myers Beach town council and its representatives to solicit input on the project.

Refer to Section 6.1 of the December 2018 OAR.

### 5.2 Public Involvement

A Public Meeting was held on February 27, 2018, at the Chapel by the Sea Presbyterian Church in Fort Myers Beach, to present graphics showing potential improvements being considered for the study area along with other project information. Public meeting invitation letters were e-mailed to all elected officials, appointed officials, and agency officials in the project area and invitation newsletters were mailed to property owners and other interested stakeholders. A total of 88 people signed in at the public meeting. A continuously running traffic simulation video and project brochures were provided in English and Spanish. Study team representatives assisted attendees by answering questions and addressing concerns about the proposed improvements. All attendees were given the opportunity to provide comments at the meeting or within the 10-day comment period. Four emails were submitted before the meeting, 35 comment forms were received at the meeting and 13 comments were received during the 10-day comment period following the meeting. Many of the comments stated a preference for a specific alternative along with some specific recommendations for refining the alternatives. In addition, comments included suggestions and concerns such as speeding and the existing speed limit on San Carlos Boulevard; request to consider a park & ride solution; request to install a traffic control device at the entrance/exit of Boardwalk Caper Condos to allow residents to enter and exit the complex, especially heading northbound on San Carlos Boulevard; adding bicycle lanes or shared-use lanes universally across the island; concerns that the U-turn at Prescott in alternative one will confuse motorists; request that pedestrian crosswalk near the base of the bridge be replaced with a pedestrian bridge; concerns that the project will not address the traffic jams experienced between Pine Ridge and Main Street. All of the comments received were taken into consideration in the development and refinement of the recommended project design.

Refer to Section 6.2 of the December 2018 OAR.



A comprehensive Public Involvement Plan was conducted for this project in compliance with the FDOT's *PD&E Manual*. The public, including disadvantaged populations present in the study area, were engaged through the methods outlined in the *Community Awareness Plan* (July 2019) for the project. In February of 2020, a newsletter was made available for the public regarding aspects of the design and other details pertaining to this project.

A public hearing is planned for February 3, 2022 in order to give interested persons an opportunity to express their views concerning the location, conceptual design, and social, economic, and environmental effects of the proposed project.

Additional details regarding the project's public involvement efforts can be found in the December 2018 *Operational Analysis Report* and the *Comments and Coordination Report* to be prepared under separate cover and included in the FDOT SWEPT project file.

## 6.0 Design Features of the Preferred Alternative

### 6.1 Engineering Details of the Preferred Alternative

Following a review of stakeholder comments and an engineering evaluation, Beach Alternative 1 and Island Alternative 2, along with the Matanzas Pass Bridge widening and Hurricane Pass Bridge improvements, have been selected as the Preferred Alternative to be advanced to the design phase for further refinement.

The preliminary design phase is being completed concurrently with the PD&E study and began as FPID 433726-2-32-01 in the fourth quarter of FY 2019.

In partnership with Lee County, LeeTran, and Town of Fort Myers Beach, this project will incorporate Lee County's Seafarer's Alternative at the intersection of Estero Boulevard and Fifth Street. The reconstructed intersection will enhance public transit mobility, pedestrian safety, and provide opportunity areas for landscaping and other aesthetic features.

FDOT is coordinating with the Town of Fort Myers Beach, Lee County, and Lee Tran on improvements throughout the project limits. Two projects will be implemented via the FDOT Local Agency Project (LAP) process. Lee County is developing plans for a new traffic signal at the intersection of Estero Boulevard and Crescent Street. The Town of Fort Myers Beach is developing plans for a new traffic signal at the intersection of Estero Boulevard and Old San Carlos Boulevard. These two projects will be constructed by local agencies separate from the SR 865 (San Carlos Boulevard) project.

On Matanzas Pass Bridge, the existing southbound Bus/Bicycle-Only lane will be converted to a general use travel lane and the existing sidewalk will be widened to create a shared use path. San Carlos Boulevard from Main Street to Hurricane Pass Bridge will be restriped to accommodate bicycle lanes in each direction of travel. The existing southbound Right-Turn-Only lane approaching Main Street will be converted to a general use travel lane that will continue across the Matanzas Pass Bridge. A new traffic signal will be constructed at Main Street.

The alternating signal at Prescott Street/Buttwood Drive will be adjusted to operate as a conventional signal. The Hurricane Pass Bridge will be modified to accommodate bicycle lanes in each direction of travel and a barrier-protected sidewalk along the west side of the bridge.

### 6.1.1 Typical Sections

The Preferred Alternative (Beach Alternative 1) includes milling and resurfacing SR 865 from Fifth Street to Main Street. It also includes the reconstruction of Estero Boulevard from north of Crescent Street to Fifth Street (Seafarer’s Alternative).

Over Matanzas Pass Bridge, the existing transit only lane would be converted to a general use lane giving the bridge two SB lanes and one NB lane. The existing 5’-10” sidewalk will be widened to create a 8’-5” shared use path. Figure 7 shows the proposed typical section.

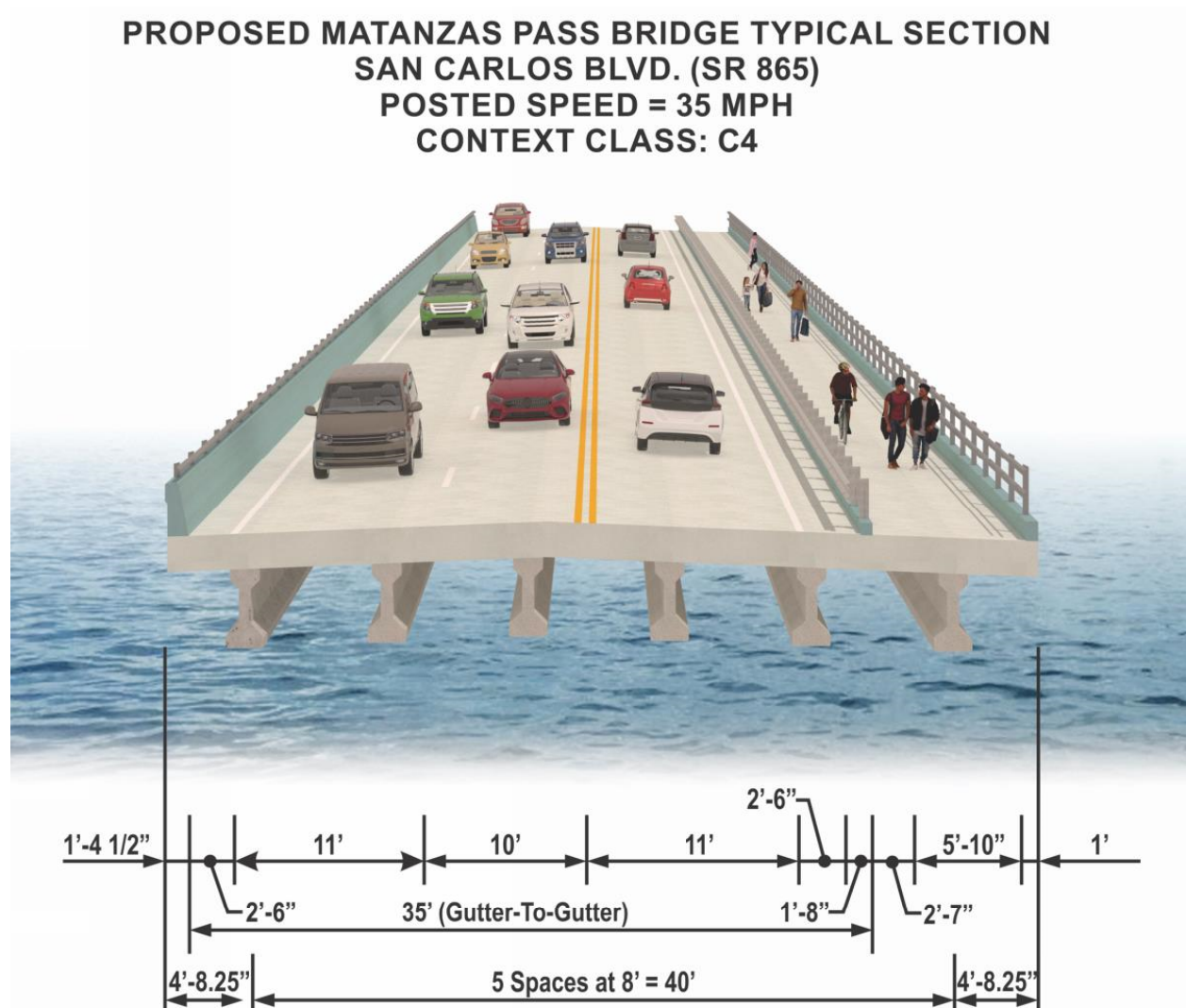
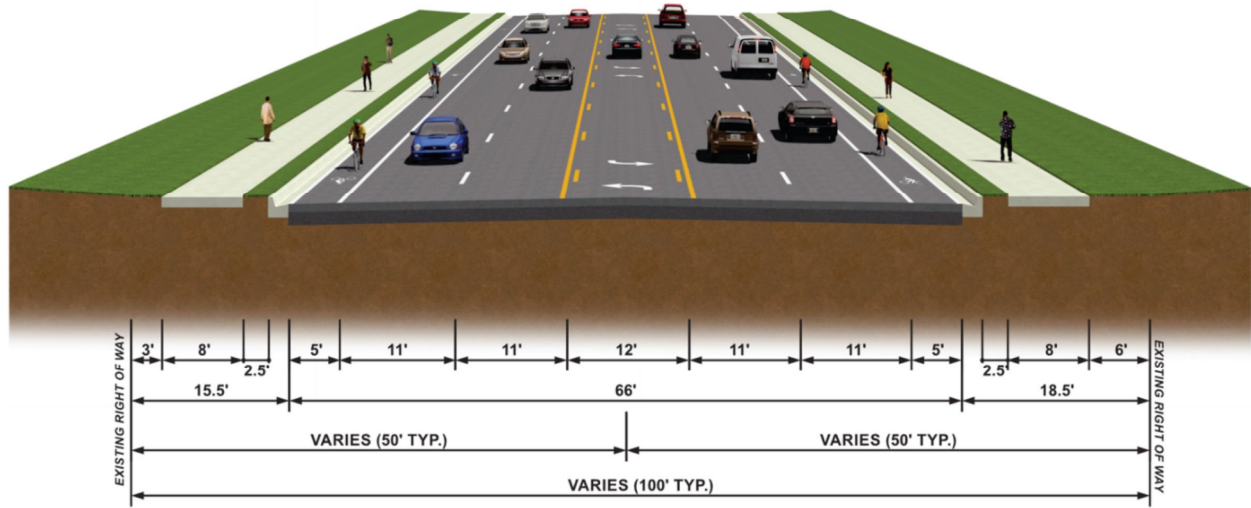

Figure 7: Proposed Typical Section – Matanzas Pass Bridge

The Preferred Alternative (Island Alternative 2) includes milling and resurfacing SR 865 from Main Street to north of Hurricane Pass Bridge to add bike lanes; see Figures 8 and 9 for typical sections. SR 865 would be widened to the west to accommodate two SB lanes and a sidewalk onto the Matanzas Pass Bridge south of Main Street. Southbound Fisherman’s Wharf frontage road will have to be shifted to accommodate the SR 865 widening.

Refer to Appendix C: Draft Typical Section Package.

**PROPOSED TYPICAL SECTION  
SAN CARLOS BLVD. (SR 865)  
FROM MAIN ST. TO HURRICANE BAY BRIDGE  
POSTED SPEED = 40 MPH  
CONTEXT CLASS: C3C**



*Figure 8: Proposed Typical Section – Main Street to Hurricane Pass Bridge*

**PROPOSED HURRICANE PASS BRIDGE SECTION  
SAN CARLOS BLVD. (SR 865)  
POSTED SPEED = 40 MPH  
CONTEXT CLASS: C3C**

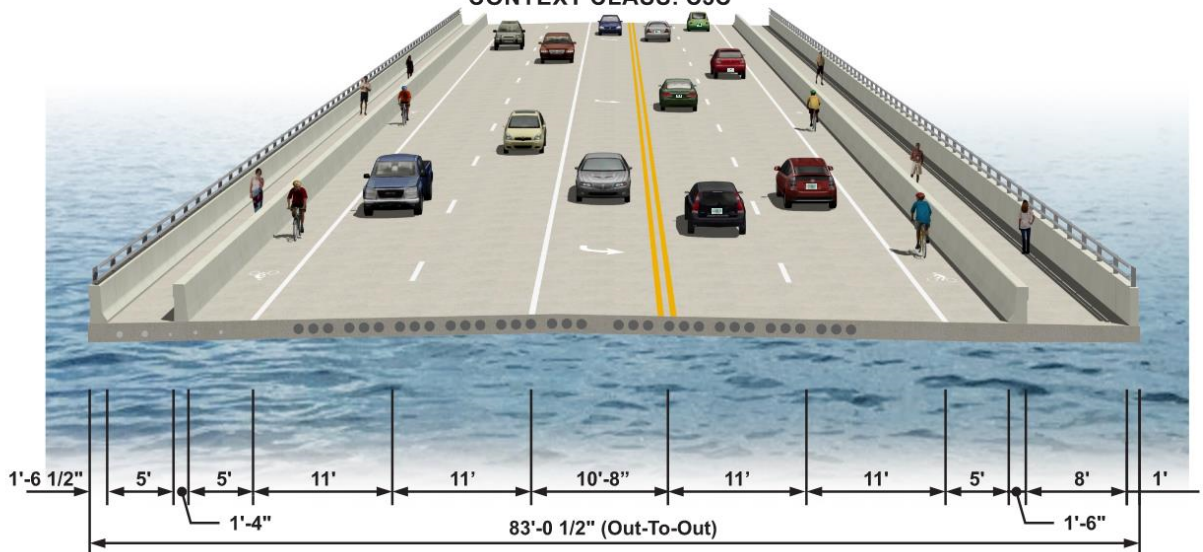

*Figure 9: Proposed Typical Section – Hurricane Pass Bridge*

### 6.1.2 Bridges and Structures

Work on Matanzas Pass Bridge (#120088) between Estero Island and San Carlos Island includes the reconfiguration of existing lanes. The existing transit only lane would be converted to a general use lane giving the bridge two SB lanes and one NB lane. Also included in this project will be the installation of guardrail and barrier wall that will separate a new shared use path from the northbound travel lanes.

Additionally, this project will add a new sidewalk along the west side of the Hurricane Pass Bridge and bike lanes.

Bridge improvements for the SR 856 (San Carlos Boulevard) bridge over Hurricane Pass (#120088) include: installing a permanent rigid concrete barrier, replacing existing expansion joints, and milling/resurfacing the roadway to meet the proposed typical section. All bridge construction activities will occur within the footprint of the existing bridge, therefore no additional slab construction, or foundation installation will be required at Hurricane Pass. The proposed rigid concrete barrier will be constructed by drilling  $\frac{3}{4}$ " diameter x 9" deep dowel holes into the existing 18" thick cast-in-place flat slab structure. All holes will be cleaned, and #5 dowels will be epoxied into each hole to anchor the barrier system. The excess deck thickness will block any epoxy from spilling into the waterway below and all excess epoxy will be removed after dowel placement. All existing bridge expansion joints will be placed with a poured joint with backer rod system and all milling/resurfacing operations will replace the existing 2" thick bridge surface.

Refer to Section 5.3.3 of the December 2018 OAR, the May 2020 Bridge Development Report – Matanzas Pass Bridge (#120088), and the May 2020 Bridge Technical Memo – Hurricane Pass Bridge (#120089).

### 6.1.3 Right-of-Way and Relocations

The proposed improvements will use the existing alignment of SR 865 and portions of three adjacent parcels. The total ROW required for the proposed improvements is approximately 0.94 acres in the vicinity of the Estero Boulevard/Fifth Street intersection to accommodate the Seafarer's Alternative improvements. This ROW will be required as follows: Lee County's Crescent Beach Family Park (0.14 acres), Lee County's vacant Seafarer's Parcel (0.73 acres) and one vacant parcel (0.07 acres) to be donated by the Town of Fort Myers Beach. There will be no change in ownership for the impacted portion of Crescent Beach Family Park (south of the Estero Boulevard). Within two vacant parcels north of Estero Boulevard, currently vacant land will be converted to transportation ROW. As the project is not widening SR 865 (i.e., for additional traffic capacity), additional ROW is not needed for stormwater management facilities (ponds) or proposed floodplain compensation sites. No residential or business relocations will result from the proposed improvements and a Conceptual Stage Relocation Plan was not prepared.

### 6.1.4 Horizontal and Vertical Geometry

The horizontal and vertical geometry for SR 865 will remain the same as existing conditions.

Estero Boulevard will be adjusted to match geometry presented in the Seafarer's Alternative.

Refer to Appendix A: Concept Roll Plots included in the SWEPT project file.

### 6.1.5 Bicycle and Pedestrian Accommodations

The Preferred Alternative includes removal of the existing pedestrian signal and crosswalk between Crescent Street and Fifth Street. A new signal will be added at Fifth Street and existing pedestrian signals will be replaced. New sidewalks in this area will be consistent with the new Seafarer's layout. This layout also includes NB and SB sharrows for bicyclist use.

This project also includes the reconfiguration of the lanes on Matanzas Pass Bridge between Estero Island and San Carlos Island. The reconfiguration will accommodate a shared use path on the northbound side of SR 865, thus, filling existing sidewalk gap between the islands. No dedicated bike lanes will be included within this section.

The Preferred Alternative includes milling and resurfacing SR 865 between Main Street and Prescott Street/ Buttonwood Drive to add bike lanes. The bike lanes will continue on to the Hurricane Pass Bridge to the end of the project. Sidewalk continuity will be provided across the west side of Hurricane Pass Bridge from Prescott Street/Buttonwood Drive.

#### 6.1.6 Multi-Modal Accommodations

As part of this project, the existing transit only lane would be converted to a general use lane giving the Matanzas Pass Bridge two SB lanes and one NB lane.

Bus stop locations will be adjusted and include bus pads at the request of LeeTran. Along Estero Boulevard, bus bays will be added in the NB and SB directions between Crescent Street and Fifth Street. Another bus bay will be added on the SB side of SR 865 (San Carlos Boulevard), south of the Main Street intersection. This bus bay provides connectivity with the LeeTran Park and Ride lot in the SW quadrant of the Main Street intersection.

Since resurfacing/construction operations affecting existing bus stops will occur at night, there are no expected interruptions in existing transit service.

#### 6.1.7 Access Management

SR 865 is Access Class 4 from the north of Crescent Street to Main Street and Access Class 7 from Main Street to north of Hurricane Pass Bridge. This project will not impact these classifications.

As part of the Preferred Alternative (Seafarers Alternative), a U-turn lane is being added south of Fifth Street to allow southbound travelers to turn around and exit the beach if they desire.

#### 6.1.8 Intersection and Interchange Concepts

The seasonal nature of the study area showed that during the non-peak season, the signalized intersections functioned at a level of service (LOS) “D” or better.

Additionally, as a part of the Preferred Alternative, the SB right turn only lane on SR 865 (San Carlos Boulevard) north of Main Street will become a combined through-right turn lane. This reconfiguration can be done because of the widening of Matanzas Pass Bridge and SR 865 south of Main Street at the proposed bus stop location.

Refer to Section 5.1.2.2 of the December 2018 OAR.

As part of the Preferred Alternative, the intersection of Fifth Street and Estero Boulevard will be reconstructed consistent with Lee County’s Seafarer’s Alternative to enhance public transit mobility, pedestrian safety, and provide opportunity areas for landscaping and other aesthetic features.

Refer to Section 4.7 of this document and Appendix A: Concept Roll Plots.

#### 6.1.9 Intelligent Transportation System and TSMO Strategies

There will be an expansion of the existing ITS infrastructure that currently terminates at Pine Ridge Road to the Fifth Street intersection. This expansion will incorporate all signals south of Pine Ridge Road into Lee County’s ATMS network.

As part of the Preferred Alternative, the alternating signal at Prescott Street/Buttonwood Drive will be adjusted to operate as a conventional signal. New signals will be added at Main Street and Fifth Street.

Signals at Estero Boulevard/Crescent Street and Estero Boulevard/Old San Carlos Boulevard will be constructed by local agencies and are considered existing conditions for the purpose of this PD&E study.

Refer to Appendix A: Concept Roll Plots.

#### 6.1.10 Utilities

Due to the proposed construction only occurring on the west side of the Matanzas Pass Bridge, no located, existing utilities are anticipated to be affected by the bridge widening. All proposed concrete barriers will include embedded conduits for the project's proposed ITS system and provide roadway lighting for the widened structure. Summit Broadband has requested a minimum of 1" – 2" diameter conduit to extend along the length of the bridge. As the project develops to final design, all conduit requests will be coordinated with FDOT and structure details will be provided as necessary to allow for adequate conduit runs.

Externally mounted utilities on the Hurricane Pass Bridge will be undisturbed. Comcast and Century Link have facilities inside conduits embedded in the bridge deck. Dowels for the proposed barrier separating the travel lanes from the new pedestrian path will not damage the existing embedded conduits.

Proposed lighting and signal mast arms will be reviewed for compliance with OSHA and NEC requirements for minimum offset from energized lines during final design. Light poles may require special design pole-arm combination to avoid overhead energized lines.

Proposed work at the Fifth Street intersection, Main Street intersection, and Prescott Street/Buttonwood Drive intersection poses the potential for underground utility conflicts with drainage installations, light pole foundations, or signal pole foundations.

With the reconfiguration of the Fifth Street intersection, Lee County requires existing PVC mains beneath new roadways, turn lanes, acceleration lanes, deceleration lanes, or driveways to be encased in split steel casing pipe with bell restraints and casing spacers. A determination on constructing the casings under a Utility Work by Highway Contractor Agreement will be made during final design.

Project design will seek to avoid and minimize impacts to existing utilities and the FDOT's coordination with potentially affected utility owners will continue throughout the Design and Construction phases. Disruptions to service and utility relocations will be minimized to the greatest extent feasible.



#### 6.1.11 Drainage and Stormwater Management Facilities

The areas along the Matanzas Bridge and the Hurricane Pass Bridge that fail to meet spread criteria are located within cross slope transitions. To alleviate these spread issues, scuppers and twelve-inch-long slots will be added to the barrier wall. Drain grates will also be installed at the beginning of the shared use path and throughout the path on the west end of the Matanzas Pass Bridge to capture the storm water runoff. Historic drainage discharge locations will remain.

The first flooding location involves two curb inlets that flood regularly underneath the north end of the Matanzas Pass Bridge. The cause of the flooding is believed to be an existing undersized pipe with an adverse slope. Per coordination meeting with FDOT on June 17, 2020, the existing 15" RCP will be replaced in kind. If a utility conflict is discovered during construction, only the crushed portion of the pipe will be replaced. The second flooding location is associated with the storm drain system located along Fisherman's Wharf, just south of Main Street. The proposed improvements will more effectively drain all the Matanzas Pass Bridge runoff into an inlet located within the limits of the new bus bay; this will eliminate any excess runoff from draining into Fisherman's Wharf.

The roadway improvements presented in the Seafarer's Alternative will use the existing drainage system as its base, with additional inlets strategically placed to collect and convey stormwater runoff from the roadway improvements to the existing outfall. Slotted trench drains have been implemented within the proposed drop-curb to address the spread and collection of stormwater runoff in the areas of the bus turnouts.

At the intersection of Estero Boulevard and Fifth Street the proposed median will contain an 8-ft. landscaped buffer and a shallow retention area that will collect stormwater runoff from the roadway via a flume. This small retention area will hold over 400 cubic feet of storage. The stormwater runoff will stage up several inches before discharging into an existing ditch bottom inlet and into the existing storm drain conveyance system. Although there is a minor increase in impervious area at this intersection, there will be a reduction in the overall stormwater runoff volume into the existing storm drain system due to the proposed retention area. The retention area will also provide some water treatment.

Refer to the "Proposed Conditions" and "Results and Conclusions" sections of the May 2020 *Drainage Design Documentation*.

### 6.1.12 Floodplain Analysis

Floodplain impacts resulting from the project were evaluated pursuant to Executive Order 11988 of 1977, Floodplain Management. The results of this evaluation are documented in the Drainage Design Documentation (May 2020), available in the project file.

The project is located within Federal Emergency Management Agency (FEMA) Flood Insurance Rate Map (FIRM) panel 12071C0554F (effective August 28, 2008) in Lee County. The FIRM map shows that the project is located entirely within the 100-year floodplain within Zones AE (1% annual chance of flooding) and Zone VE (greater than 1% annual chance of flood). These floodplains are due to coastal storm surge potential from the Gulf of Mexico, Matanzas Pass and Hurricane Pass. On Estero Island, floodplain elevations range from approximately 16 feet NAVD 1988 along the south side of SR 865 near Crescent Beach Family Park to 10 feet NAVD 1988 along the east side of the Matanzas Pass Bridge. On San Carlos Island, floodplain elevations range from approximately 13 feet NAVD 1988 along the west side of the Matanzas Pass Bridge to 9 feet NAVD 1988 at Buttonwood Drive. North of the Hurricane Pass Bridge, the floodplain elevation is approximately 12 feet NAVD 1988.

Although the project is anticipated to occur primarily within the existing SR 865 right-of-way, some minor floodplain encroachment may be required to accommodate the proposed mobility improvements. These encroachments will be minimal as the proposed improvements follow the existing roadway and bridges within the coastal floodplain. Flood elevations and risks will not be increased since there are no proposed improvements that will be a significant change in roadway elevation from existing conditions. Due to the broad coastal nature of the local floodplain, no floodplain compensation measures are proposed.

Replacement drainage structures for this project are limited to hydraulically equivalent structures which are not expected to increase the backwater surface elevations. The limitations to the hydraulic equivalency being proposed are basically due to restrictions imposed by the geometrics of design, existing development, cost feasibility, or practicability. An alternative encroachment location is not considered since it does not meet the project's purpose and need or is economically unfeasible. Since flooding conditions in the project area are inherent in the topography or are a result of other outside contributing sources, and there is no practical alternative to eradicate flooding problems in any significant amount, existing flooding may be improved in some areas, but may continue in other areas. However, the proposed improvements will not result in adverse flooding or floodplain impacts in the project vicinity.

Furthermore, the project will not affect existing flood heights or floodplain limits. There will be no significant change in the potential for interruption or termination of emergency service or emergency evacuation routes as the result of construction of this project. Therefore, it has been determined that this encroachment is not significant.

Refer to the "Proposed Conditions" and "Results and Conclusions" sections of the May 2020 *Drainage Design Documentation*.

### 6.1.13 Transportation Management Plan

As part of the Transportation Management Plan for the Preferred Alternative, construction will be done outside of peak beach season and during night-time hours to minimize down time, excessive congestion, and pedestrian/bicyclist safety concerns. Additionally, night-time lane closures are anticipated for milling, resurfacing, and re-striping. For portions of the Seafarer's Alternative, off-peak detours are anticipated.

The preliminary sequence of construction is included below:

- Phase 1
  - Construct roadway widening and drainage improvements at Main Street intersection.
  - Install Main Street signals, mainline lighting, and ITS.
  - Install barrier wall across Matanzas Pass Bridge.
  - Install barrier wall on Hurricane Pass Bridge.
- Phase 2
  - Open SB SR 865 to two lanes across Matanzas Pass Bridge.
  - Construct Seafarers Alternative.
  - Install Fifth Street signals.
- Phase 3
  - Mill and resurface.
  - Install final signing and place final pavement markings.

#### 6.1.14 Special Features

Portions of the Seafarer's Alternative project area along Estero Boulevard from Crescent Street to Fifth Street are on the seaward side of the Coastal Construction Control Line (CCCL). See Figure 10 for Coastal Construction Line limits. Work done in this area must be permitted through the Florida Department of Environmental Protection (FDEP). This process will be completed as part of the project's environmental permitting process.

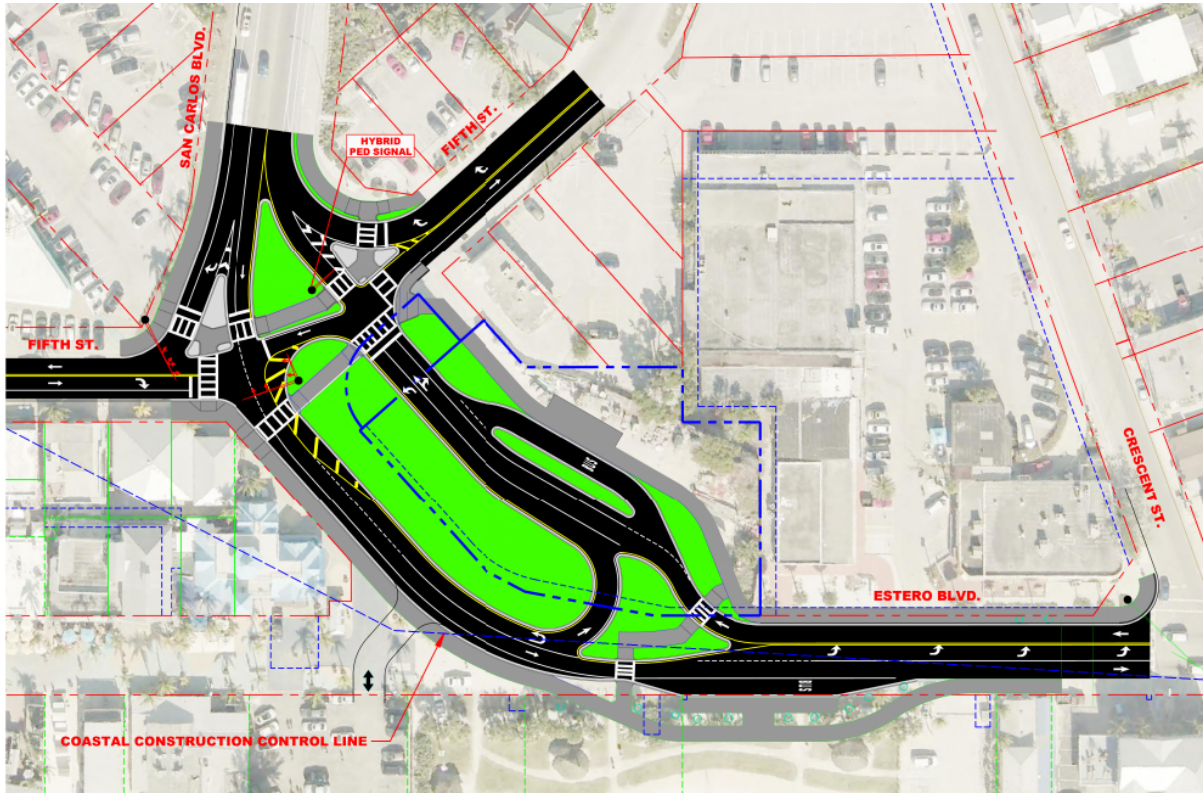

Figure 10: Coastal Construction Line Location Map

#### 6.1.15 Design Variations and Design Exceptions

The following items are anticipated to require approval of a Design Variation Memorandum:

- 5' Bicycle lane width (from Main Street to the end of the project)
- 10'-8" Auxiliary lane width (left turn lane on Hurricane Pass Bridge)
- 5' Sidewalk width (on Hurricane Pass Bridge)
- 8'-5" Shared use path width (on Matanzas Pass Bridge)
- 2'-6" Bridge shoulder width (on Matanzas Pass Bridge)

Matanzas Pass Bridge exceeds maximum 5% longitudinal grade, however this bridge potentially qualifies for and ADA exemption.

Per ADA Standards for Transportation Facilities, Chapter 2, Scoping:

- § 202.4 Alterations Affecting Primary Function Areas. In addition to the requirements of 202.3, an alteration that affects or could affect the usability of or access to an area containing a primary function shall be made so as to ensure that, to the maximum extent feasible, the path of travel to the altered area, including the rest rooms, telephones, and drinking fountains serving the altered area, are readily accessible to and usable by individuals with disabilities, unless such alterations are disproportionate to the overall alterations in terms of cost and scope as determined under criteria established by the Attorney General. In existing transportation facilities, an area of primary function shall be as defined under regulations published by the Secretary of the Department of Transportation or the Attorney General.
- § Advisory 202.4 Alterations Affecting Primary Function Areas. An area of a building or facility containing a major activity for which the building or facility is intended is a primary function area. Department of Justice ADA regulations state, "Alterations made to provide an accessible path of travel to the altered area will be deemed disproportionate to the overall alteration when the cost exceeds 20% of the cost of the alteration to the primary function area." (28 CFR 36.403 (f)(1)). See also Department of Transportation ADA regulations, which use similar concepts in the context of public sector transportation facilities (49 CFR 37.43 (e)(1)).

Based on the additional cost and loading provided by meeting the ADA requirements of this existing facility, this bridge would potentially qualify for exemption from ADA requirements per 202.4 above. Assuming a construction cost of \$35/SY and a material cost of \$125/SY, the total cost along the tangent section of the bridge will be approximately 22% of the total project cost.

Refer to the May 2020 *Bridge Development Report – Matanzas Pass Bridge (#120088)* included in the FDOT SWEPT project file.

#### 6.1.16 Cost Estimates

A present-day construction cost estimate was developed for the Preferred Alternative in the December 2018 OAR. This estimate has been updated to include the cost of Beach Alternative 1, Island Alternative 2, Seafarers Alternative, and modified costs for improvements to Matanzas Pass Bridge. The projected construction, design, CEI, and Right-of-Way costs are as follows:

Construction: \$5,489,592.05

Design (12% of Construction): \$658,751.05

CEI (12% of Construction): \$658,751.05

Right-of-Way Costs: \$0

Total: \$6,807,094.15

Refer to Appendix B: Construction Cost Estimate.

## 6.2 Summary of Environmental Impacts of the Preferred Alternative

### 6.2.1 Land Uses

The proposed improvements will use the existing alignment of SR 865 and portions of three adjacent parcels. The total ROW required for the proposed improvements is approximately 0.94 acres in the vicinity of the Estero Boulevard/Fifth Street intersection to accommodate the Seafarer's Alternative improvements. Within two parcels north of Estero Boulevard, currently vacant land will be converted to transportation ROW. The impacted portion of Crescent Beach Family Park will remain under Lee County ownership. The Section 4(f) review is discussed in Section 6.2.2. The proposed project will continue to support the existing and future land uses within the project and surrounding areas. Significant land use changes are not anticipated to occur along the project corridor if the proposed project is implemented.

This project is consistent with the Transportation Element and Future Land Use Element of the Town of Fort Myers Beach Comprehensive Plan (as amended November 2009) and LeePlan Future Land Use Element Chapter II and Transportation Element 4 Chapter III (as amended through June 2020). As discussed previously in Section 1.3, this project is included in the Lee County MPO's 2045 LRTP Cost Feasible Plan and FY 2020/21 - FY 2024/25 TIP and FDOT's current 2021-2024 STIP.

### 6.2.2 Section 4(f)

The following evaluation was conducted pursuant to Section 4(f) of the U.S. Department of Transportation Act of 1966, as amended, and 23 CFR Part 774.

Seven potential resources within the project limits were evaluated. Summaries for these resources are provided in the following paragraphs. Pending the conclusion of coordination, full documentation including maps, figures and final FDOT determinations will be provided in the Cultural Resources Attachment.

#### **Crescent Beach Family Park**

The Crescent Beach Family Park (1100 Estero Boulevard) is a 2.2-acre public recreational park within the Town of Fort Myers Beach. The park property was purchased by Lee County in 2010 and is managed by Lee County Parks and Recreation. The park sits at the foot of the Matanzas Pass Bridge on the south side of Estero Boulevard along a 400-foot stretch of beach. The property is used for outdoor recreation and beach access by the public.

The northern half of the park property contains three covered picnic areas with two picnic tables/benches each, a pervious walking path and decorative landscaping consisting of shell/rock, numerous palm trees, shrubs, ferns and bunch grasses served by a sprinkler irrigation system. The eastern portion of the park contains a parking area with two designated handicap parking spaces, one parking space dedicated for County/police vehicles and two portable restrooms. The southern half of the park is predominantly open space with beach sand, including two sand volleyball courts. There are four beach access points at the park's southern border (including one ADA-accessible ramp), one bicycle rack and various trash and recycling receptacles throughout the park.

Associated with the proposed Seafarer's Alternative improvements at Estero Blvd. and Fifth Street, a new bus bay is proposed within the SR 865 right-of-way to service LeeTran Route 400 (Beach Park & Ride/Lovers Key). This bus bay will require the relocation of the existing 12-foot sidewalk, roadway lighting, park signage, landscaping and irrigation along the south side of the roadway. With the reconfiguration of the Estero Boulevard/Fifth Street intersection, the proposed improvements will impact approximately 0.14 acres within the northern fringe of Crescent Beach Family Park. The improvements will require the removal and relocation of existing landscaping (approximately 23 palm trees and several miscellaneous shrubs, ferns and bunch grasses) and sprinkler irrigation systems along the northern edge of the park. Although this impact footprint comprises approximately 6.4% of the park's total acreage, the amenities or portions of amenities impacted are not significant to the overall public recreational use/enjoyment of the overall park property. Given the urban setting of the corridor in which the park is located, there are no significant impacts to the aesthetics or viewshed associated with the park property. Significant highway traffic noise impacts were not identified at/within this park.

Based on the evaluation conducted, the FDOT has presumed the significance of the Crescent Beach Family Park. Based on the nature of the impacts, the FDOT is presenting a preliminary "de minimis" impact determination at the public hearing. The public is being provided the opportunity to review and provide comments on these impacts at the public hearing. Following the hearing, FDOT District One will complete coordination with Lee County and submit the final coordination for FDOT OEM's review/approval of the final "de minimis" determination in conjunction with their review and approval of this Type 2 CE document.

The FDOT will coordinate further with Lee County Parks and Recreation for the removal and relocation/replacement of existing park signage, landscaping, and sprinkler irrigation systems within the impacted area along the northern edge of the Crescent Beach Family Park.

### **Seafarer's Parcel**

Preliminary research encountered geographic information system (GIS) data (i.e., the Lee County Property Appraiser GIS website and the "Florida Parks and Recreational Facilities Boundaries in Florida - 2019" layer maintained by the University of Florida GeoPlan Center) which labels Lee County's Seafarers parcel (1113 Estero Boulevard, see Attachment 1) as a "park" resource. This parcel, owned by Lee County, is necessary for the Seafarers Alternative improvements at the intersection of Estero Boulevard and Fifth Street. Coordination with County staff indicated that this vacant property has never been used for public recreation purposes and is not planned for future recreational purposes. A field review conducted on October 12, 2020 confirms that the entire perimeter of this parcel is fenced and the western entrance is explicitly signed with the Lee County logo as "private property" and for "official use only". As the official with jurisdiction (OWJ), Lee County provided their concurrence dated January 20, 2021 that this resource is not significant in meeting the recreational objectives of Lee County and the Fort Myers Beach area. Therefore, the provisions of Section 4(f) do not apply to the Seafarer's Parcel.

### **Estero-Bonita "Trail" Segment**

Per the FDOT Shared Use Nonmotorized (SUN) Trail database, the Estero-Bonita "trail" corridor is shown as an existing trail running along the northbound (east) side of SR 865 (San Carlos Boulevard/ Estero Boulevard) from approximately 250 feet south of Pine Ridge Road (north end) in Fort Myers Beach, Florida to County Road 887/Old US 41 Road in Bonita Springs. This total "trail" corridor is 18.62 miles in length. The proposed improvements from north of the Hurricane Pass Bridge to Crescent Street will affect approximately 1.2 miles of the overall corridor. This feature is a sidewalk/shared use pathway available for public use within the road existing SR 865 ROW. The primary purpose of this feature is to facilitate the movement of pedestrians over the Matanzas Pass Bridge and allow both bicycle and pedestrian users to cross the Hurricane Pass Bridge.

From the south end of the project to the Main Street intersection, the existing "trail" segment consists of a 5'-10" sidewalk used to convey pedestrian traffic across the Matanzas Pass Bridge. Due to the narrow width throughout this section, bicyclists may travel along the northbound roadway shoulder or are instructed by signage to walk their bikes along the sidewalk over the bridge. From Main Street to the north end of the project, the sidewalk width widens to 8 feet and there are no apparent restrictions for bicycle users. Neither trail markers nor designation signs are present within the project limits. There are no other amenities evident to suggest an intended recreation (i.e., non-transportation) use.

Within the project limits, the Estero-Bonita "trail" segment runs along the northbound (east) side of SR 865 (San Carlos Boulevard/Estero Boulevard) from Crescent Street to north of the Hurricane Pass Bridge. Public access is available at the SR 865 intersection at Fifth Street (in Fort Myers Beach on Estero Island), throughout most of San Carlos Island (except for bridge portions) and along SR 865 north of the Hurricane Pass Bridge.



The sidewalk and shared path facilities crossing the east side of the Matanzas Pass and Hurricane Pass bridges, respectively, are the only such features permitting pedestrian and bicycle movement from Estero Island and San Carlos Island to the mainland. There are numerous other facilities available to pedestrians and bicyclists on Estero Island. The only other bridge off Estero Island is the Big San Carlos Pass Bridge which connects to Lovers Key, approximately 5.8 miles southeast of the project study area. The Big San Carlos Pass, which is similarly under study for proposed improvements, contains substandard width sidewalks and no dedicated bicycle facilities (i.e., bicyclists must share the SR 865 travel lanes with motorists).

Although this "trail" feature appears to meet current ADA requirements at the major intersection crossings, there are no interim landing areas on the Matanzas Pass Bridge to provide rest areas for disabled users to adjust/recover on the steep uphill/downhill portions of the bridge.

As the official with jurisdiction (OWJ), Lee County provided their concurrence dated January 20, 2021 that this resource is not significant in meeting the recreational objectives of Lee County and the Fort Myers Beach area. Therefore, the provisions of Section 4(f) do not apply to the Estero-Bonita "trail" segment.

#### **Matanzas Pass Bridge South Fishing Pier**

The Matanzas Pass South Fishing Pier (1151 First Street) is a 0.03-acre recreational facility located on Estero Island just off of First Street under the south side of the SR 865 bridge over the Matanzas Pass waterway. This 7.5-foot wide pier facility extends approximately 200 feet in length from the southern seawall under the bridge to nearly the southern navigational fender within the waterway and is used for saltwater fishing. There is a paved "pay by space" parking lot at the south end (approximately 14 spaces) and the pier's amenities include a portable restroom, an information kiosk, bicycle racks and trash/recycling/fishing line receptacles. These amenities service the fishing pier but are part of separate resource easement/lease agreement. The property is used by the public for the purposes of saltwater fishing, wildlife viewing and sight-seeing.

The fishing pier was constructed by the FDOT in conjunction with the 1980 replacement of the Matanzas Pass Bridge under FDOT Project # 12530-3614. This resource and the underlying landward portions are owned by the FDOT, while the waterward portions are Sovereign Submerged Lands (SSLs) owned by the State of Florida Trustees of the Internal Improvement Trust Fund (TIITF) and used via easement.

Access to the Matanzas Bridge South Fishing Pier is provided by First Street under the southern landward portion of Matanzas Pass/north end of Estero Island. The pier is also accessible by the small dock at the shoreline. This park serves the local land uses which are primarily commercial and services, single- and multi-family residential and vacation/rental properties. The facility uses lights under the existing bridge and appears to be open at night. There is no fee at this time.

The bridge construction (minor widening along the west/southbound side) will occur well above the Matanzas Bridge South Fishing Pier and there will be no change in the vertical geometry (i.e., low-member elevation) of the bridge of the bridge. Although the work duration will be temporary (i.e., less than the time needed for construction of the project) and there will be no change in the ownership of the land, a floating barge is anticipated to be needed for debris collection and minor construction activities adjacent to the channel, which could temporarily interfere with the ability to use the west side

of the fishing pier. Parking under the west side of the bridge within the pay lot is anticipated to be similarly impacted. The Matanzas Bridge South Fishing Pier was constructed as part of the construction of the SR 865 bridge over Matanzas Pass under FDOT Project # 12530-3614.

Per 23 CFR 774.11 (i), when a property is formally reserved for a future transportation facility before or at the same time a park, recreation area, or wildlife and waterfowl refuge is established, and concurrent or joint planning or development of the transportation facility and the Section 4(f) resource occurs, then any resulting impacts of the transportation facility will not be considered a use as defined in 23 CFR 774.17. Therefore, Section 4(f) does not apply to the Matanzas Bridge South Fishing Pier.

### **Matanzas Pass Bridge South Dinghy Dock**

The Matanzas Pass Bridge South Dinghy Dock (1151 First Street) is an approximately 15 feet wide x 65 long (975 square feet) recreational facility located on Estero Island just off of First Street under the south side of the SR 865 bridge over the Matanzas Pass waterway. This feature occurs under and adjacent to the FDOT's Matanzas Pass Bridge South Fishing Pier. This dock is used by the public for the purposes of saltwater fishing and boating.

The dock includes an ADA-compliant wooden and metal walkway and handrails railings on both sides, along with boat fenders and tie-off rails. As allowed by an existing FDOT lease agreement, there is a paved "pay by space" parking lot (approximately 14 spaces), a portable restroom, an information kiosk, bicycle racks and trash/recycling/fishing line receptacles adjacent to the south side the dock.

The dock, adjacent parking lot and amenities are managed by the Town of Fort Myers Beach Public Works via a 25-year "vehicle parking and landscape beautification" lease agreement with the FDOT for the construction of the parking lot just south of the pier and the dinghy dock under/adjacent to the pier. This lease began August 15, 2000 and expires August 14, 2025. The FDOT owns the underlying landward portions, while the waterward portions are SSLs owned by the State of Florida TIIF and used via easement. The lease agreement allows the Town access across the FDOT's property to construct, repair and maintain the dock, as well as access to the water to use the dock. Per coordination with the Town of Fort Myers, this facility provides a public transportation function due to the interplay of the mooring field users anchored in the Matanzas Pass waterway and downtown businesses, as well as a public recreational function.

The bridge construction (minor widening along the west/southbound side) will occur well above the Matanzas Pass Bridge South Dinghy Dock and there will be no change in the vertical geometry (i.e., low-member elevation) of the bridge. Although the work duration will be temporary (i.e., less than the time needed for construction of the project) and there will be no change in the ownership of the land, a floating barge is anticipated to be needed for debris collection and minor construction activities adjacent to the channel, which could temporarily interfere with the ability to use the dock on the west side of the fishing pier. Parking under the west side of the bridge within the pay lot is anticipated to be similarly impacted. The Matanzas Pass Bridge South Dinghy Dock is allowed by the 25-year "vehicle parking and landscape beautification" lease agreement with the FDOT. This lease agreement specifically clarifies that the underlying use of landward portions is as a transportation facility.

Per 23 CFR 774.11 (i), when a property is formally reserved for a future transportation facility before or at the same time a park, recreation area, or wildlife and waterfowl refuge is established, and concurrent

or joint planning or development of the transportation facility and the Section 4(f) resource occurs, then any resulting impacts of the transportation facility will not be considered a use as defined in 23 CFR 774.17. Therefore, Section 4(f) does not apply to the Matanzas Bridge South Dinghy Dock.

### **Matanzas Pass Bridge North Fishing Pier**

The Matanzas Pass Bridge North Fishing Pier (700 Fishermans Wharf Drive) is a 0.37-acre recreational facility located on San Carlos Island just off of Fishermans Wharf Drive under the north side of the SR 865 bridge over the Matanzas Pass waterway. The pier structure encompasses approximately 1,875 square feet (0.04 acre), with the remaining acreage as the parking lot. This 7.5-foot wide pier facility extends approximately 240 feet in length from the northern seawall under the bridge to nearly the northern navigational fender within the waterway and is used for saltwater fishing, wildlife viewing and sight-seeing. There is a dirt parking lot at the north end of this facility that provides limited parking for approximately 12 vehicles, an information kiosk and trash/fishing line receptacles.

The fishing pier was constructed by the FDOT in conjunction with the 1980 replacement of the Matanzas Pass Bridge under FDOT Project # 12530-3614. This resource is managed by the Lee County Parks and Recreation. The FDOT owns the underlying landward portions, while the waterward portions are SSLs owned by the State of Florida TITF and used via easement.

Access to the Matanzas Pass Bridge North Fishing Pier is provided by Fishermans Wharf Drive at the north end of Matanzas Pass/south end of San Carlos Island. This park serves the local land uses which include some single-family residential and vacation/rental properties. The facility uses lights under the existing bridge and appears to be open at night. There is no fee at this time.

The bridge construction (minor widening along the west/southbound side) will occur well above the Matanzas Bridge Fishing North Pier and there will be no change in the vertical geometry (i.e., low-member elevation) of the bridge.

Although the work duration will be temporary (i.e., less than the time needed for construction of the project) and there will be no change in the ownership of the land, a floating barge is anticipated to be needed for debris collection and minor construction activities adjacent to the channel, which could temporarily interfere with the ability to use the west side of the fishing pier. Parking within the lot under the west side of the bridge may be similarly impacted. The Matanzas Bridge North Fishing Pier was constructed as part of the 1980 construction of the SR 865 bridge over Matanzas Pass under FDOT Project #12530-3614.

Per 23 CFR 774.11 (i), when a property is formally reserved for a future transportation facility before or at the same time a park, recreation area, or wildlife and waterfowl refuge is established, and concurrent or joint planning or development of the transportation facility and the Section 4(f) resource occurs, then any resulting impacts of the transportation facility will not be considered a use as defined in 23 CFR 774.17. Therefore, Section 4(f) does not apply to the Matanzas Bridge North Fishing Pier.

### **Great Calusa Blueway Paddling Trail**

The Great Calusa Blueway Paddling Trail occurs within Hurricane Bay, just south of the project's northern limit. The portion of the Great Calusa Blueway Paddling Trail is within Phase 1 of the overall Great Calusa Blueway network within Lee County, which includes 97 miles of marked paddling trails in Phase 1 & 2 and 90 miles of unmarked paddling trails along rivers and tributaries in Phase 3. This paddling trail is also considered as Segment 12 (Pine Island/Estero Bay segment) of the Florida Circumnavigational Paddling Trail. Lee County manages this public use trail for saltwater paddling, fishing, wildlife viewing, sightseeing and other passive recreation activities. There are no other designated paddling trails within or immediately adjacent to the project limits.

Lee County manages this public use trail. The lands underlying the Hurricane Bay waterway are owned as SSLs by the State of Florida TITF under Florida Statute 253.03 and Chapter 18-21 Florida Administrative Code (FAC). This trail is loosely defined and does not have a definite width or location within the Hurricane Bay waterway. There are no amenities specific to this paddling trail within or immediately adjacent to the project limits. The only in-channel features are navigational aids for motorized boats and watercraft.

All four quadrants of Hurricane Bay within the project limits are private property, so access within the project limits is limited slightly. However, given the numerous boat docks and marina within the Estero Bay area, there are extensive opportunities for public access to this paddling trail. The nearest public park access points are at Lee County's Bunche Beach and Bowditch Regional Park facilities which are 1.3 miles northwest and 0.97 miles west of the Hurricane Pass Bridge, respectively. There are no posted/known restrictions on the public's use of this paddling trail. Based on a review of available bridge plans, the vertical clearance of the Hurricane Pass Bridge typically ranges from 6.02 to 6.62 feet above the mean high-water elevation (1.43 feet North American Vertical Datum/NAVD 1988). Usage of the paddling trail under the bridge could be limited during storm or high-water events and/or strong currents.

As the official with jurisdiction (OWJ), Lee County provided their concurrence dated January 20, 2021 for the significance of this resource in meeting the recreational objectives of Lee County and the San Carlos Island community.

The Great Calusa Blueway Paddling Trail crosses under the SR 865 Hurricane Pass Bridge. All proposed improvements on SR 865 at this location will occur on the bridge deck. There will be no in-water work or alterations to the horizontal or vertical geometry of the existing bridge at this location. Therefore, there will be no "use" of the Great Calusa Blueway Paddling Trail. Based on the evaluation conducted, the FDOT has determined that there will be no Section 4(f) "use" to the Great Calusa Blueway Paddling Trail.

### 6.2.3 Cultural Resources

The evaluation of the project's potential involvement with historical and archaeological resources was documented in the *Cultural Resource Assessment Survey* (dated March 2020) and an addendum to the *Cultural Resource Assessment Survey* (dated October 2020). Both documents are available within the SWEPT project file.

The historical/architectural APE includes the footprint of construction within the existing ROW and immediately adjacent parcels on the west side of SR 865 as contained within 150-feet from the centerline of the roadway. In addition, historic resources located on immediately adjacent parcels in areas where new traffic signals are proposed (Estero Boulevard and Crescent Street; Estero Boulevard/SR 865/Fifth Street; Estero Boulevard and Old San Carlos Boulevard; and SR 865 and Main Street) were recorded and evaluated.

No previously recorded historic resources were located within the APE. As a result of field survey, 39 newly identified historic resources (8LL02650-8LL02684, 8LL02706-9) were recorded and evaluated. The architectural styles represented include 11 Masonry Vernacular (8LL02650, 8LL02651, 8LL02653-55; 8LL02659; 8LL02661; 8LL02672, 8LL02673, 8LL02676; 8LL02679), eight Frame Vernacular (8LL02658; 8LL02660; 8LL02666; 8LL02678; 8LL02680; 8LL02682-84), two Industrial Vernacular (8LL02677; 8LL02681), five Commercial (8LL02652, 8LL02656, 8LL02657, 8LL02674, 8LL02675), nine mobile homes (no style) (8LL02662-65; 8LL02667-71); as well as four building complex resource groups (8LL02706-9) constructed between approximately 1939 and 1972. These resources are common examples of their respective architectural styles without significant historical associations. Therefore, none appear eligible for listing in the National Register of Historic Places (NRHP), either individually or as part of a historic district.

The archaeological APE was defined as the area contained within the footprint of construction where the proposed design changes are to occur. Background research and a review of the Florida Master Site File (FMSF) and the NRHP indicated that one previously recorded archaeological site is located within the project APE. This site, 8LL00777, the San Carlos Island Site, is a shell midden recorded in 1987 as the result of an informant interview (FMSF). The State Historic Preservation Officer (SHPO) has not evaluated the site. A review of relevant site location information for environmentally similar areas within Charlotte, Hendry, and Lee Counties including the Lee County Archaeological Sensitivity Map indicated a moderate potential for prehistoric archaeological sites. However, the APE was determined to have a low to very low potential for prehistoric archaeological sites due to the tidal and partially inundated soils and infill. There was also a low potential for historic archaeological sites. The results of background research and archaeological field survey, including excavation of 41 shovel tests and surface reconnaissance found no evidence of 8LL00777 and did not identify any prehistoric or historic archaeological sites within the APE.

Based on the results of the background research and field survey, there are no significant historic properties within the APE. Therefore, the project will have no effect on any prehistoric or historic archaeological sites or historic resources that are listed, eligible, or that appear to be potentially eligible for listing in the NRHP. These findings were submitted to the State Historic Preservation Officer (SHPO) on March 24, 2020. The SHPO provided their concurrence with these findings on April 13, 2020.

The Addendum to the *Cultural Resource Assessment Survey* was subsequently prepared to include additional project area associated with the proposed Seafarer's Alternative intersection concept at Estero Boulevard and Fifth Street. This effort applied the same historical/architectural and archaeological APE buffers. As a result of the historical/architectural field survey, three historic resources (8LL02835-8LL02837) were newly identified, recorded, and evaluated within the APE. These resources included three Commercial style buildings along Estero Boulevard constructed between approximately 1947 and 1972. These resources are common examples of their respective architectural styles. Overall, the newly identified historic resources have been altered, lack sufficient architectural features, and are not significant embodiments of a type, period, or method of construction. In addition, background research did not reveal any historic associations with significant persons and/or events. Thus, the resources do not appear eligible for listing in the NRHP, either individually or as a part of a historic district. Based on the background research and survey results, including the excavation of seven shovel tests, no archaeological sites that are listed, eligible for listing, or that appear potentially eligible for listing in the NRHP were located within the APE.

Given the results of background research and field survey documented within the Addendum to the *Cultural Resource Assessment Survey*, no cultural resources that are listed, eligible for listing, or that appear potentially eligible for listing in the NRHP were located within the APE. Therefore, the proposed undertaking will not be involved with cultural resources. These determinations were submitted to the SHPO on October 22, 2020. On November 17, 2020, the SHPO provided their determination that the proposed project will have no effect to historic properties listed, potentially eligible, or eligible for listing, on the NRHP. The CRAS, CRAS Update and SHPO coordination were submitted to the Seminole Tribe of Florida's Tribal Historic Preservation Office (THPO) for their files on March 1, 2021. Within this submittal, the THPO was provided the opportunity for comment and stated no objection with the project findings. The SHPO and THPO concurrence letters are included within the SWEPT project file.

#### 6.2.4 Wetlands

As documented within the December 2020 *Natural Resource Evaluation* (NRE) for this project, the boundaries of all wetlands and other surface waters within the 500-foot study area corridor were approximated using both a desktop and field review. Jurisdictional wetlands and surface waters identified within the project study area consist of estuarine habitats common to the Matanzas Pass and Hurricane Pass waterbodies. These habitats include open water and mangrove forests; none of which will be impacted as a result of project activities. No jurisdictional delineations/determinations were conducted.

Based on the evaluation completed, the results of this PD&E study indicate that the roadway improvements and safety considerations proposed by this project are not anticipated to result in wetland or surface water impacts. Impacts to local wetlands have been avoided as a result of selection of the proposed alignment and design considerations.

The NRE was submitted on January 27, 2021 to the following agencies for review and concurrence with the various natural resource findings outlined in the NRE: USFWS, NMFS, USACE, USEPA, SFWMD, FWC, FDEP and FDACS.

In accordance with EO 11990, the FDOT has undertaken all actions to minimize the destruction, loss, or degradation of wetlands, and to preserve and enhance the natural and beneficial values of wetlands in carrying out the agency's responsibilities. Since no impacts resulting from the proposed alignment are anticipated to wetlands or surface waters, no compensatory wetland mitigation is required.

#### 6.2.5 Protected Species and Habitat

A 500-foot project study area (i.e., 250 feet east and west of the SR 865 centerline) was assessed for the presence of suitable habitat for federal- and state-listed and protected species in accordance with 50 CFR Part 402 of the Endangered Species Act (ESA) of 1973, as amended, Chapters 5B-40: *Preservation of Native Flora of Florida* and 68A-27, FAC, *Rules Relating to Endangered or Threatened Species*, and the FDOT PD&E Manual. The results of this evaluation were documented within the December 2020 NRE prepared for the project and included in the FDOT SWEPT project file.

Literature reviews, agency database searches and field reviews for these species and their suitable habitat were conducted within and adjacent to the project corridor. Sixteen (16) federal-listed species, twelve (12) state-listed species, and several protected non-listed species were determined to have a likelihood for utilization of habitats within or adjacent to the study area based on database and literature research, and field evaluations of the project area and adjacent habitats and general wildlife surveys conducted by qualified scientists in September 2019, February 2020, and November 2020. Two federally-protected species, the Florida bonneted bat and common bottlenose dolphin, were documented during corridor field survey efforts. Effects determinations for the various federal- and state-protected species are presented in the following paragraphs and the rationale for these determinations is found in the NRE document.

### **Federally-Listed Species**

The FDOT recommended findings of *may affect, not likely to adversely affect* for the smalltooth sawfish, loggerhead sea turtle, Kemp's Ridley sea turtle, green sea turtle, eastern indigo snake, American alligator, American crocodile, Florida bonneted bat and West Indian manatee. Findings of *no effect* were recommended for the Florida scrub-jay, red knot, piping plover, wood stork, Eastern black rail, aboriginal prickly-apple, and beautiful pawpaw.

### **USFWS Critical Habitat**

The project is within designated Critical Habitat for two species. While the study area lies within NMFS-designated smalltooth sawfish and USFWS-designated West Indian manatee Critical Habitat, the proposed action will not result in destruction or adverse modification of critical habitat for either species. The project is outside of any local Critical Habitat polygons for the piping plover. The proposed critical habitat designation/rulemaking process for the Florida bonneted bat is in progress. However, critical habitat has not been officially designated and the entire project lies outside of any units currently being considered for critical habitat.

### **State-Listed Species**

The FDOT recommended *no adverse effect* anticipated findings for the little blue heron, reddish egret, roseate spoonbill, tricolored heron, and least tern. Findings of *no effect* anticipated were recommended for the gopher tortoise, Florida sandhill crane, Florida burrowing owl, snowy plover, American oystercatcher, black skimmer and southeastern American kestrel.

### **Otherwise Protected Species**

Therefore, the FDOT has provided a finding of no adverse effect anticipated for the bald eagles (protected under the federal Bald and Golden Eagle Protection Act and Migratory Bird Treaty Act), the common bottlenose dolphin (protected under the federal Marine Mammal Protection Act) and roosting bat species (protected from take in Florida under state rules 68A-4.001 and 68A-9.010, FAC).

Following coordination with the applicable resource agencies (discussed previously in Section 6.2.4), minor modifications were made to effect determinations for several species as follows:

- NMFS: changing the Endangered Species Act Section 7 effect determinations for the smalltooth sawfish and swimming sea turtles (green, loggerhead, and Kemp's Ridley) from *may affect, not likely to adversely affect* to *no effect*.
- USFWS: changing the Endangered Species Act Section 7 effect determinations for the green, loggerhead, and Kemp's Ridley sea turtles and the eastern indigo snake from *may affect, not likely to adversely affect* to *no effect*.

Based on the use of the USFWS Consultation Key couplet 12b to reach a MANLAA-Programmatic effect determination for the Florida bonneted bat, the FDOT commits to implementing Best Management Practices (BMPs) 1, 3, 4 and 5 for this project.

The agency coordination, including USFWS, NMFS and FWC concurrence letters are included within the SWEPT project file.



### 6.2.6 Essential Fish Habitat

An Essential Fish Habitat (EFH) Assessment has been prepared and consultation has been completed in accordance with the Magnuson-Stevens Fishery Conservation and Management Act (MSFCMA). It has been determined that this project will not have adverse effects to EFH.

Essential Fish Habitat (EFH) and Habitat Areas of Particular Concern (HAPC) are designated by the National Oceanic and Atmospheric Administration (NOAA), NMFS and the regional fishery management councils for species managed under the Magnuson-Stevens Fishery Conservation and Management Act as amended (MSA). The MSA established eight Fishery Management Councils (FMCs) across the country that are tasked with creating and amending Fishery Management Plans (FMPs). Certain estuarine habitats within the project area are designated as EFH as identified in the 2005 generic amendment of the FMPs for the Gulf of Mexico. The generic amendment was prepared by the Gulf of Mexico FMC as required by the 1998 amendment to the MSA.

The proposed project is located within an area designated as EFH for three FMPs: Gulf of Mexico, Coastal Migratory Pelagic, and Highly Migratory Species management plans. NOAA Fisheries has identified and described EFH for 60 managed species within the project study area. These include the red drum, 43 managed reef species, 4 managed shrimp species, 3 managed coastal migratory pelagic species, and 9 managed highly migratory species. Of the sixty managed fisheries species identified, many are likely to occur nearshore at only one life stage (typically early development stages). Additional discussion of the life stage(s) and associated habitat(s) where individual species commonly occur for each EFH are provided in the NRE available in the project file.

Within the study area, EFH occurs within Matanzas Pass and Hurricane Bay. A review of designated EFH identified a single species, the royal red shrimp, as having a potential for occurrence in the project study of "none" because of the lack of suitable habitat at any life stage. Thirty-one (31) managed reef species, two managed shrimp species, one managed coastal migratory pelagic species, and four managed highly migratory species were determined to have a "low" potential for occurrence in the project study area. This determination was made based on the presence of suitable habitat within the project study area at one or more life stages. One red drum species, ten managed reef species, one managed shrimp species, two managed coastal migratory pelagic species, and five managed highly migratory species were determined to have a "moderate" potential for occurrence in the project study area. This determination was made based on the presence of suitable habitat within the project study area at one or more life stages and the species previously documented nearby.

No managed species were determined to have a "high" potential for occurrence in the project study area. This determination was made based on the presence of suitable habitat within the project study area at one or more life stages and direct observation during field visits. In their January 29, 2021 e-mail response, the NMFS stated that they were satisfied with the content of the NRE and believe that with the implementation of BMPs, that any impacts to NMFS trust resources (including EFH) will be minimal.

As all construction will take place on the existing bridge deck at both waterways, impacts to EFH are not anticipated as a result of this project.

### 6.2.7 Highway Traffic Noise

A *Noise Study Report* (NSR) was prepared in March 2021 (available in the project file) for the proposed project using methodology established by the FDOT in the PD&E Manual and the *Traffic Noise Modeling and Analysis Practitioners Handbook*. The NSR utilized the project design plans for the proposed improvements. The objectives of the NSR were to identify noise-sensitive sites adjacent to the project corridor, to evaluate the existing and future traffic noise levels at the sites with the proposed improvements, and to evaluate the need for and effectiveness of noise abatement measures. Additional objectives include the evaluation of construction noise and vibration impacts, and the identification of noise "contours", which are provided to assist local authorities in exercising land use control over the remaining undeveloped lands, so as to avoid development of lands for use by incompatible activities adjacent to the roadways within the local jurisdictions.

Predicted 2015 Existing, 2040 Design Year No-Build, and 2040 Design Year Build condition traffic noise levels were calculated using validated Traffic Noise Model (TNMv2.5) models for discrete noise-sensitive receptors (based on land use and activity categories) throughout the project corridor. The TNM propagates sound energy, in one-third octave bands, between highways and nearby receptors, taking into account the intervening ground's acoustical characteristics and topography, and rows of buildings. The study area was divided into 76 distinct noise sensitive common noise environments (CNEs) within the project limits (see NSR Appendix B). In addition to four field measurement sites, 245 receptor locations were modeled within these 76 CNEs. Substantial noise increase impacts (i.e., a >15 db(A) increase over existing conditions) are not predicted at any of these 245 receptors. A total of 73 CNEs were found to have no noise impacts for the proposed improvements. Three (3) CNEs consisting of six receptors (comprised of Noise Abatement Criteria (NAC) land use categories B and E) were found to be impacted by the proposed improvements. Of the three impacted CNE's, CNE 37 (a two-story residential building unit at the Sportsman's Cove Yacht & Racquet Club) and CNE 42 (Maria's Smokehouse and Seafood restaurant) were determined to be isolated impacted receptors. Abatement would not be feasible at either location as FDOT policy states that noise abatement must provide a benefit at a minimum of two impacted receptors per location.

Future 2040 build-condition noise levels were modelled to approach or exceed the applicable NAC for 4 sites at CNE 26, which represents the Sunnyland Mobile Home Park adjacent to the northeastern quadrant of the SR 865/Main Street intersection on San Carlos Island. For this CNE, a potential noise barrier was analyzed. Based on preliminary findings, it was determined that a 124' long and 8' tall noise barrier is needed to meet the feasible noise reduction criteria and reasonable noise reduction design goal. Upon further examination, it was determined that factors such as existing utilities, right of way acquisition, drainage, and maintenance of the noise barrier would be factors that may impact the feasibility by requiring additional costs. A more detailed cost estimate was completed of the items needed for the CNE 26 potential noise barrier that would be additional from the highway improvement project. These items include removal and replacing of the existing sidewalk for construction purposes, drainage needs, right of way acquisition, and utility relocation, if deemed necessary.

A noise barrier 8 to 16 feet in height, located approximately 12' from the existing edge of pavement within the right of way, meets the feasible and reasonable insertion loss criteria. However, with these additional items, the total cost of the noise barrier is \$288,501.69. Based on two benefitted receptors, the reasonable cost effectiveness criteria is exceeded with a cost per benefitted receptor of \$144,250.84, which exceeds FDOT's cost-feasible threshold of less than \$42,000 per benefitted receptor.

CNE 42 represents the Maria's Smokehouse and Seafood screened dining area enclosure and is located on the soundbound side of SR 865, north of Hurricane Pass. 2040 future build-condition hourly equivalent sound levels meet or exceed the applicable NAC at 5 noise-sensitive receptors.

A noise barrier was evaluated following FDOT Special Land Use procedures. The noise barrier at heights ranging from 8-22 ft. would provide a benefit to all of the impacted area and meet the noise reduction design goal. For a 10 ft. noise barrier to be cost reasonable, 41 people need to use the facility per day for one hour. The seating capacity of the screened in dining area is about 40 persons; with about 10 tables and 40 chairs for accommodating patrons. It is assumed that use of 10 person per hour during the lunch hours of 11am to 1pm, then dinner hours 5 pm to 7 pm it is possible for the person-hours requirement to be met at every noise barrier height.

To meet safety requirements, such as access sight distance, a set back from each access point would be needed to provide horizontal sight distance of a stopped vehicle being able to view traffic on the mainline and safely proceed onto SR 865. In addition, in order to meet clear zone safety requirements, the noise barrier would need to be constructed along the backside of the sidewalk. This would place the potential noise barrier approximately 4 feet from the front of the building. The proximity to the building would require substantial impacts to the building during construction. Therefore, construction of the noise barrier would not be feasible without impacting the building. In addition, factors such as existing utilities, right of way acquisition, drainage, and maintenance of the noise barrier could impact the feasibility and might require additional costs.

Based on the noise analyses performed to date, there are no feasible and reasonable solutions available to mitigate the noise impacts at CNEs 26, 37 and 42. No noise barriers are recommended for further consideration.

The predominant construction activities associated with the SR 865 improvement project are expected to be earth removal, hauling, grading, and paving. Construction vehicles and activities such as usage of impact hammers (jack hammers, hoe rams, etc.) may create sporadic, temporary, but disruptive construction noise and/or vibration impacts to nearby sensitive receptors. Construction of the proposed project may cause temporary noise and/or vibration impacts to nearby developed land uses. If additional land uses are developed in the vicinity of the proposed project prior to construction, then additional construction noise and vibration impacts could occur. It anticipated that application of the FDOT's Standard Specifications for Road and Bridge Construction will minimize potential construction noise and vibration impacts. However, should unanticipated noise or vibration concerns, issues, or impacts arise during project construction, the Project Manager, in concert with the District Noise Specialist and the Contractor, will investigate additional methods of controlling these impacts.

### 6.2.8 Contamination

A Level I contamination evaluation was conducted for the study and the *Contamination Screening Evaluation Report* (CSER) (revised January 2021) was prepared under separate cover pursuant to FHWA's Technical Advisory T 6640.8A and the *FDOT PD&E Manual*. The CSER is available in the project file. The Level I assessment was conducted to identify and evaluate sites containing hazardous materials, petroleum products, or other sources of potential environmental contamination along the SR 865 project corridor. The CSER included standard environmental site assessment practices of reviewing records of regulatory agencies, site reconnaissance, literature review, and personal interviews of individuals and business owners within the limits of the project. For purposes of this report, the contamination study area encompasses the right of way and properties within 500 feet of the corridor, non-landfill solid waste sites within 1,000 feet, and Superfund sites within one-half mile of the project.

Based on a document and site review, a total of 17 sites were identified for potential contamination involvement within and adjacent to the project study area. Of these, 8 sites were ranked "High", 1 site was ranked "Medium", 6 sites were ranked "Low", and 2 sites were ranked "No Risk" for potential contamination.

For the sites ranked "Low" and "No Risk" no further action is required at this time. These sites/facilities have the potential to impact the proposed project, based on select variables these have been determined to have low risk to the project at this time. Variables that may change the risk ranking include a facility's non-compliance to environmental regulations, new discharges to the soil or groundwater, and modifications to current permits. Should any of these variables change, assessment of these facilities shall be conducted during subsequent project development phases.

A summary of the information on the "High" and "Medium"-risk sites is provided in Table 2, page 20 within the CSER. More detailed information for each facility is provided in the CSER. All High and Medium risk sites are directly adjacent to the recommended improvements. A portion of the "High"-risk parcel identified at 1113 Estero Boulevard (former Exxon #6719) will be used for the Seafarer's Alternative (reconstruction of the Estero Boulevard/Fifth Street intersection). The West Coast Surf Shop parcel (1035 Estero Boulevard) is also a "High"-risk site immediately adjacent to this intersection reconstruction. No ROW will be acquired from this parcel or any other "High" or "Medium" sites along the project limits. For those locations with a risk ranking of "High" or "Medium", the FDOT will conduct Level II screening prior to construction commencement if it is determined during the project's design that construction activities could be in their vicinity or if the site will be subject to right-of-way acquisition. The results will be summarized in a Level 2 Impact to Construction Report (L2-ICR). Future project design plans will contain marked contamination polygons and general notes as applicable. The FDOT will oversee any remediation activities necessary.

Based on the work proposed for the Matanzas Pass and Hurricane Pass bridges, a NESHAP asbestos survey and screening for metals-based coatings (MBCs) were conducted for each bridge as part of this PD&E study. Although testing found no asbestos-containing materials (ACMs), bridge plans for both bridges indicate there may be asbestos-containing components that were inaccessible for testing. ACMs might be encountered during construction. No metal components with suspect metals-based coatings were identified by the survey for the SR 865 bridge over Matanzas Pass. However, the survey for the SR 865 bridge over Hurricane Pass indicated metals-based coatings were identified in the paint chip sample collected from the blue water pipeline along the west side of the bridge. With the proposed improvements remaining within the limits of the existing Hurricane Pass Bridge, this water pipeline is not anticipated to be impacted.

Based on the results of these asbestos surveys, no further testing is recommended at this time. It should be noted that suspect materials, in addition to those identified during this survey could exist within the structure in areas not accessible to inspectors at the time of the survey. Should suspect materials other than those which were identified during this survey be uncovered during the renovation or demolition process, those materials should be assumed to be ACM until sampling and analysis can confirm or refute their asbestos content. Regarding MBCs, for bridges constructed in 1980 or earlier, PD&E Manual Chapter 20 states the following: “Based on the age of each bridge, lead-based coating shall be assumed to be present within faying surfaces of splices and top flanges embedded in concrete decks as well as other surfaces. Abatement plans for handling, management and removal of asbestos-containing materials and lead-based coating must be prepared before demolition, modification, or rehabilitation of the bridge.”

***APPENDIX A***  
***CONCEPT ROLL PLOTS***

---

# San Carlos Boulevard (SR 865)

from North of Crescent Street to North of Hurricane Bay Bridge

# Project Development and Environment Study



District One | Lee County  
FPID: 433726-1-32-01

Beach Alternative 1

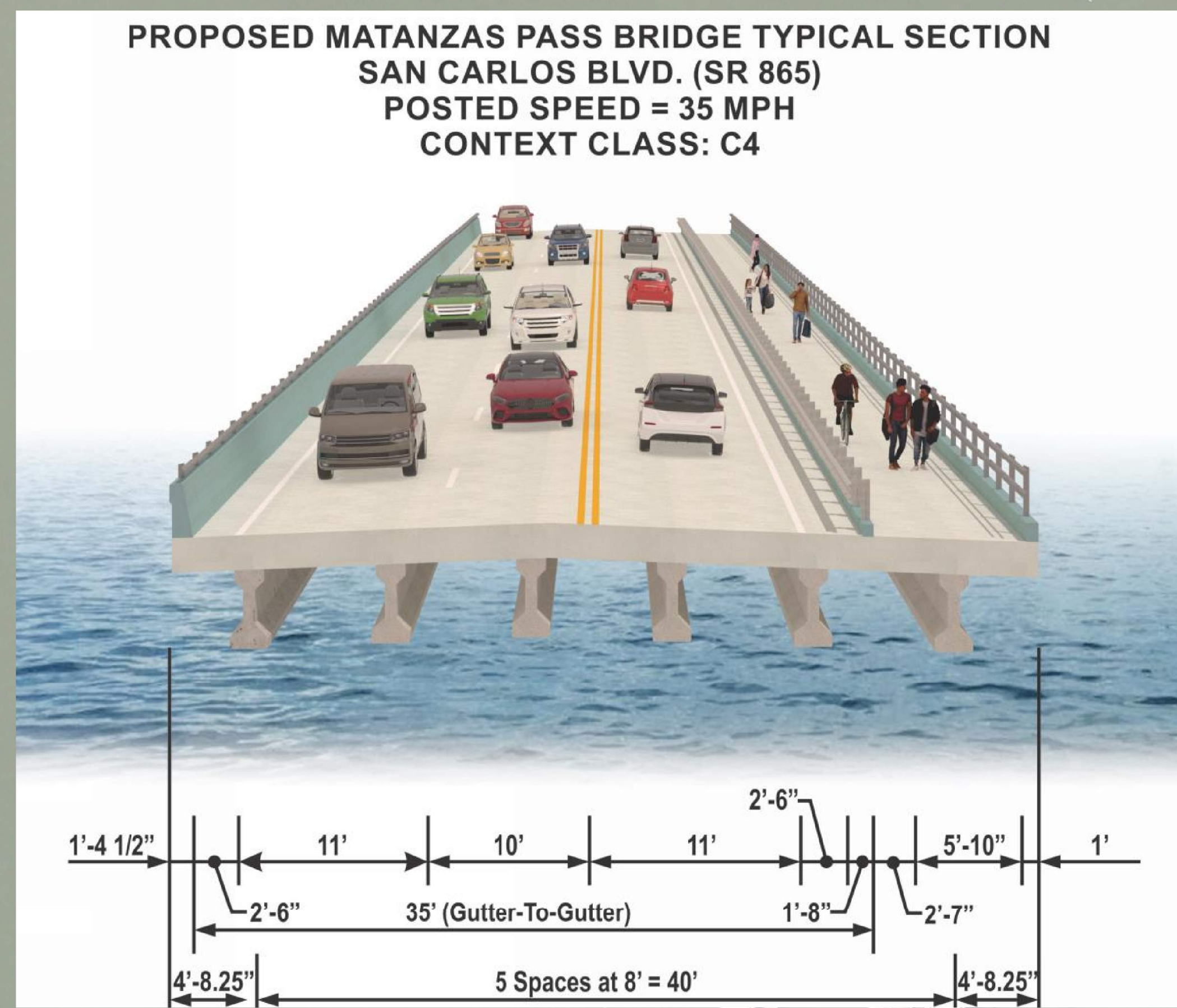

**LEGEND**

	EXISTING SIDEWALK		PROPOSED R/W
	PROPOSED SIDEWALK/SHARED-USE PATH		EXISTING PROPERTY LINE
	PROPOSED BRIDGE SIDEWALK		EXISTING EASEMENT
	PROPOSED ROADWAY IMPROVEMENT		WETLAND LIMIT
	PROPOSED BRIDGE IMPROVEMENT		HIGH CONTAMINATION RISK
	PROPOSED BARRIER WALL		MEDIUM CONTAMINATION RISK
	PROPOSED GUARDRAIL		LOW CONTAMINATION RISK
	EXISTING R/W		BUS/TROLLEY STOP

## Fifth Street Intersection and Matanzas Pass Bridge

*Preferred Alternative*

# San Carlos Boulevard (SR 865)

from North of Crescent Street  
to North of Hurricane Bay Bridge

# Project Development and Environment Study

Island Alternative 2



**Main Street Intersection to Hurricane Bay Bridge**

*Preferred Alternative*



***APPENDIX B***  
***CONSTRUCTION COST ESTIMATE***

---

### Florida Department of Transportation Working Detail Cost Estimate

Proposal: T1830

Estimate Total:\* \$5,489,592.05 (A only)

Letting ID:

Construction Days: 0

Estimated By: Gena Batman (PG132GB)

Proposal Letting Date:

Primary County: LEE

Run By: Gena Batman (PG132GB)

Fin Proj #	Federal Aid	County	Project Name	Work Type	Letting Date	Project Total **
43372625201	N/A	LEE	SR 865 (SAN CARLOS) FROM N CRESCENT ST TO N OF HURRICANE PASS BRIDGE - INTERSECTION IMPROVEMENT	X4 - Widening & Resurfacing	2/22/2023 12:00:00 AM	\$5,489,592.05

\* excludes Non-Bid Items

\*\* includes Non-Bid Items

Alternate Description	Category Alternate Set	Category Alternate Member	Item Alternate Set	Item Alternate Member	Total*	Include
					\$5,489,592.05	√

\* excludes Non-Bid Items

Obs	Item Number	Item Description	Supplemental Description	T Spec	Unit	Quantity	Unit Price	Extended Amount	Low Cost
	0101 1	MOBILIZATION	43372625201		LS	1.000	\$448,781.00	\$448,781.00	√
	0102 1	MAINTENANCE OF TRAFFIC	43372625201		LS - DA	1.000	\$411,726.00	\$411,726.00	√
	0102 60	WORK ZONE SIGN			ED	6670.000	\$0.24	\$1,600.80	√
	0102 71 15	TEMPORARY BARRIER, F&I, ANCHORED			LF	2453.000	\$27.87	\$68,365.11	√
	0102 74 1	CHANNELIZING DEVICE- TYPES I, II, DI, VP, DRUM, OR LCD			ED	8100.000	\$0.10	\$810.00	√
	0102 99	PORTABLE CHANGEABLE MESSAGE SIGN, TEMPORARY			ED	172.000	\$10.82	\$1,861.04	√
	0102115	TYPE III BARRICADE			ED	480.000	\$0.29	\$139.20	√
	0102913 21	REMOVABLE TAPE, WHITE, SOLID 6"			GM	1.400	\$9,858.40	\$13,801.76	√
	0102913 31	REMOVABLE TAPE, YELLOW, SOLID, 6"			GM	1.180	\$9,553.97	\$11,273.68	√
	0104 10 3	SEDIMENT BARRIER			LF	1113.000	\$1.65	\$1,836.45	√
	0104 18	INLET PROTECTION SYSTEM			EA	16.000	\$114.43	\$1,830.88	√
	0107 1	LITTER REMOVAL			AC	4.690	\$32.25	\$151.25	√
	0107 2	MOWING			AC	0.800	\$62.44	\$49.95	√
	0108 1	MONITOR EXISTING STRUCTURES-INSPECTION AND SETTLEMENT MONITORING	43372625201	P	LS	1.000	\$15,000.00	\$15,000.00	√
	0110 1 1	CLEARING & GRUBBING	43372625201		LS - AC	0.440	\$66,617.51	\$29,311.70	√
	0110 3	REMOVAL OF EXISTING STRUCTURES/BRIDGES	43372625201		LS - SF	2143.000	\$45.25	\$96,970.75	√
	0110 4 10	REMOVAL OF EXISTING CONCRETE			SY	1755.000	\$23.64	\$41,488.20	√
	0120 1	REGULAR EXCAVATION			CY	3825.000	\$9.94	\$38,020.50	√
	0120 6	EMBANKMENT			CY	2389.000	\$14.55	\$34,759.95	√
	0160 4	TYPE B STABILIZATION			SY	1350.000	\$23.44	\$31,644.00	√
	0285710	OPTIONAL BASE, BASE GROUP 10			SY	1752.000	\$29.17	\$51,105.84	√
	0327 70 5	MILLING EXISTING ASPHALT PAVEMENT, 2" AVG DEPTH			SY	24078.000	\$3.08	\$74,160.24	√
	0327 70 6	MILLING EXISTING ASPHALT PAVEMENT, 1 1/2" AVG DEPTH			SY	803.000	\$7.84	\$6,295.52	√
	0334 1 13	SUPERPAVE ASPHALTIC CONC, TRAFFIC C			TN	174.000	\$192.25	\$33,451.50	√

Obs	Item Number	Item Description	Supplemental Description	T Spec	Unit	Quantity	Unit Price	Extended Amount	Low Cost
	0337 7 83	ASPHALT CONCRETE FRICTION COURSE,TRAFFIC C, FC-12.5, PG 76-22			TN	2898.000	\$131.47	\$381,000.06	√
	0400 0 11	CONCRETE CLASS NS, GRAVITY WALL INDEX 400-011			CY	160.000	\$913.40	\$146,144.00	√
	0400 4 4	CONCRETE CLASS IV, SUPERSTRUCTURE			CY	426.400	\$988.71	\$421,585.94	√
	0415 1 4	REINFORCING STEEL - BRIDGE SUPERSTRUCTURE			LB	23417.000	\$1.20	\$28,100.40	√
	0425 1203	INLETS, CURB, TYPE 9, J BOT, <10'			EA	1.000	\$8,660.63	\$8,660.63	√
	0425 1321	INLETS, CURB, TYPE P-2, <10'			EA	1.000	\$8,495.94	\$8,495.94	√
	0425 1361	INLETS, CURB, TYPE P-6, <10'			EA	1.000	\$6,127.18	\$6,127.18	√
	0425 1525	INLETS, DITCH BOTTOM, TYPE C, PARTIAL			EA	1.000	\$3,703.41	\$3,703.41	√
	0425 1711	INLETS, GUTTER, TYPE V, <10'			EA	3.000	\$5,286.59	\$15,859.77	√
	0425 2 41	MANHOLES, P-7, <10'			EA	2.000	\$4,594.61	\$9,189.22	√
	0425 2 43	MANHOLES, P-7, PARTIAL			EA	1.000	\$2,940.75	\$2,940.75	√
	0425 2 91	MANHOLES, J-8, <10'			EA	1.000	\$8,397.49	\$8,397.49	√
	0425 2 93	MANHOLES, J-8, PARTIAL			EA	1.000	\$4,750.03	\$4,750.03	√
	0425 11	MODIFY EXISTING DRAINAGE STRUCTURE		P	EA	2.000	\$7,390.72	\$14,781.44	√
	0430174112	PIPE CULVERT, OPTIONAL MATERIAL, ROUND, 12"SD			LF	8.000	\$166.31	\$1,330.48	√
	0430174115	PIPE CULVERT, OPTIONAL MATERIAL, ROUND, 15"SD			LF	153.000	\$65.59	\$10,035.27	√
	0430174118	PIPE CULVERT, OPTIONAL MATERIAL, ROUND, 18"SD			LF	42.000	\$112.95	\$4,743.90	√
	0430174124	PIPE CULVERT, OPTIONAL MATERIAL, ROUND, 24"SD			LF	8.000	\$174.59	\$1,396.72	√
	0436 1 1	TRENCH DRAIN, STANDARD			LF	288.000	\$292.92	\$84,360.96	√
	0458 1 11	BRIDGE DECK EXPANSION JOINT, NEW CONSTRUCTION, F&I POURED JOINT WITH BACKER ROD			LF	532.000	\$56.93	\$30,286.76	√
	0458 1 21	BRIDGE DECK EXPANSION JOINT, REHABILITATION, POURED JOINT WITH BACKER ROD			LF	810.000	\$63.21	\$51,200.10	√
	0460 71 2	METAL TRAFFIC RAILING, STEEL POST AND RAIL		A	LF	2143.000	\$115.47	\$247,452.21	√
	0515 1 2	PIPE HANDRAIL - GUIDERAIL, ALUMINUM			LF	40.000	\$64.17	\$2,566.80	√
	0515 4 1	BULLET RAIL, SINGLE RAIL			LF	390.000	\$58.91	\$22,974.90	√
	0515 4 2	BULLET RAIL, DOUBLE RAIL			LF	207.000	\$57.18	\$11,836.26	√

Obs	Item Number	Item Description	Supplemental Description	T Spec	Unit	Quantity	Unit Price	Extended Amount	Low Cost
	0520 1 7	CONCRETE CURB & GUTTER, TYPE E			LF	696.000	\$27.52	\$19,153.92	√
	0520 1 10	CONCRETE CURB & GUTTER, TYPE F			LF	2191.000	\$31.34	\$68,665.94	√
	0520 2 4	CONCRETE CURB, TYPE D			LF	562.000	\$27.94	\$15,702.28	√
	0520 2 8	CONCRETE CURB, TYPE RA			LF	266.000	\$37.53	\$9,982.98	√
	0520 70	CONCRETE TRAFFIC SEPARATOR, SPECIAL- VARIABLE WIDTH		P	SY	180.000	\$99.51	\$17,911.80	√
	0521 72 43	SHOULDER CONCRETE BARRIER, CURB AND GUTTER BARRIER			LF	716.000	\$267.99	\$191,880.84	√
	0521 72 44	SHOULDER CONCRETE BARRIER, 44" PIER PROTECTION BARRIER/CRASH WALL			LF	160.000	\$441.59	\$70,654.40	√
	0522 1	CONCRETE SIDEWALK AND DRIVEWAYS, 4" THICK			SY	1703.000	\$53.15	\$90,514.45	√
	0522 2	CONCRETE SIDEWALK AND DRIVEWAYS, 6" THICK			SY	784.000	\$58.11	\$45,558.24	√
	0527 2	DETECTABLE WARNINGS			SF	382.000	\$33.27	\$12,709.14	√
	0550 10222	FENCING, TYPE B, 5.1-6.0, W/ VINYL COATING			LF	675.000	\$25.32	\$17,091.00	√
	0550 60623	FENCE GATE, TYPE B VINYL, DOUBLE, 12.1 -18.0' OPENING			EA	2.000	\$2,520.00	\$5,040.00	√
	0570 1 2	PERFORMANCE TURF, SOD			SY	1973.000	\$4.60	\$9,075.80	√
	0630 2 11	CONDUIT, FURNISH & INSTALL, OPEN TRENCH			LF	4957.000	\$12.92	\$64,044.44	√
	0630 2 11	CONDUIT, FURNISH & INSTALL, OPEN TRENCH			LF	107.000	\$12.94	\$1,384.58	√
	0630 2 11	CONDUIT, FURNISH & INSTALL, OPEN TRENCH			LF	928.000	\$12.93	\$11,999.04	√
	0630 2 12	CONDUIT, FURNISH & INSTALL, DIRECTIONAL BORE			LF	935.000	\$25.68	\$24,010.80	√
	0630 2 12	CONDUIT, FURNISH & INSTALL, DIRECTIONAL BORE			LF	10966.000	\$25.65	\$281,277.90	√
	0630 2 12	CONDUIT, FURNISH & INSTALL, DIRECTIONAL BORE			LF	400.000	\$25.68	\$10,272.00	√
	0630 2 14	CONDUIT, FURNISH & INSTALL, ABOVEGROUND			LF	15.000	\$33.70	\$505.50	√
	0630 2 15	CONDUIT, FURNISH & INSTALL, BRIDGE MOUNT			LF	475.000	\$34.53	\$16,401.75	√
	0630 2 65	CONDUIT, REMOVE, BRIDGE MOUNT			LF	505.000	\$5.80	\$2,929.00	√
	0632 7 1	SIGNAL CABLE- NEW OR RECONSTRUCTED INTERSECTION, FURNISH & INSTALL			PI	3.000	\$7,357.31	\$22,071.93	√
	0633 1121	FIBER OPTIC CABLE, F&I, UNDERGROUND,2-12 FIBERS			LF	1073.000	\$3.23	\$3,465.79	√

Obs	Item Number	Item Description	Supplemental Description	T Spec	Unit	Quantity	Unit Price	Extended Amount	Low Cost
	0633 1123	FIBER OPTIC CABLE, F&I, UNDERGROUND,49-96 FIBERS			LF	16655.000	\$3.63	\$60,457.65	√
	0633 2 31	FIBER OPTIC CONNECTION, INSTALL, SPLICE			EA	242.000	\$43.87	\$10,616.54	√
	0633 2 32	FIBER OPTIC CONNECTION, INSTALL, TERMINATION			EA	84.000	\$101.73	\$8,545.32	√
	0633 3 11	FIBER OPTIC CONNECTION HARDWARE, F&I, SPLICE ENCLOSURE			EA	7.000	\$948.41	\$6,638.87	√
	0633 3 14	FIBER OPTIC CONNECTION HARDWARE, F&I, BUFFER TUBE FAN OUT KIT			EA	7.000	\$97.36	\$681.52	√
	0633 3 16	FIBER OPTIC CONNECTION HARDWARE, F&I, PATCH PANEL- FIELD TERMINATED			EA	5.000	\$870.85	\$4,354.25	√
	0633 3 51	FIBER OPTIC CONNECTION HARDWARE, ADJUST/MODIFY SPLICE ENCLOSURE			EA	1.000	\$555.99	\$555.99	√
	0634 4600	SPAN WIRE ASSEMBLY, REMOVE- POLES REMAIN			PI	2.000	\$1,560.06	\$3,120.12	√
	0635 2 11	PULL & SPLICE BOX, F&I, 13" x 24" COVER SIZE			EA	58.000	\$820.16	\$47,569.28	√
	0635 2 11	PULL & SPLICE BOX, F&I, 13" x 24" COVER SIZE			EA	7.000	\$820.49	\$5,743.43	√
	0635 2 11	PULL & SPLICE BOX, F&I, 13" x 24" COVER SIZE			EA	39.000	\$820.27	\$31,990.53	√
	0635 2 12	PULL & SPLICE BOX, F&I, 24" X 36" COVER SIZE			EA	16.000	\$1,603.05	\$25,648.80	√
	0635 2 13	PULL & SPLICE BOX, F&I, 30" X 60" RECTANGULAR OR 36" ROUND COVER SIZE			EA	7.000	\$3,386.58	\$23,706.06	√
	0639 1121	ELECTRICAL POWER SERVICE, F&I, UNDERGROUND, METER FURNISHED BY POWER COMPANY			AS	2.000	\$3,140.32	\$6,280.64	√
	0639 1122	ELECTRICAL POWER SERVICE, F&I, UNDERGROUND, METER PURCHASED BY CONTRACTOR			AS	2.000	\$3,225.72	\$6,451.44	√
	0639 2 1	ELECTRICAL SERVICE WIRE, FURNISH & INSTALL			LF	425.000	\$7.54	\$3,204.50	√
	0639 2 1	ELECTRICAL SERVICE WIRE, FURNISH & INSTALL			LF	511.000	\$7.54	\$3,852.94	√
	0639 3 11	ELECTRICAL SERVICE DISCONNECT, F&I, POLE MOUNT			EA	2.000	\$1,446.93	\$2,893.86	√
	0639 3 11	ELECTRICAL SERVICE DISCONNECT, F&I, POLE MOUNT			EA	2.000	\$1,446.93	\$2,893.86	√
	0641 2 11	PRESTRESSED CONCRETE POLE, F&I, TYPE P-II PEDESTAL			EA	1.000	\$1,703.45	\$1,703.45	√
	0641 2 12	PRESTRESSED CONCRETE POLE, F&I, TYPE P-II SERVICE POLE			EA	3.000	\$1,657.54	\$4,972.62	√
	0641 2 13	PRESTRESSED CONCRETE POLE, F&I, TYPE P-III			EA	2.000	\$8,634.97	\$17,269.94	√

Obs	Item Number	Item Description	Supplemental Description	T Spec	Unit	Quantity	Unit Price	Extended Amount	Low Cost
	0646 1 11	ALUMINUM SIGNALS POLE, PEDESTAL			EA	23.000	\$1,615.94	\$37,166.62	√
	0646 1 12	ALUMINUM SIGNALS POLE, FURNISH & INSTALL PEDESTRIAN DETECTOR POST			EA	3.000	\$1,574.51	\$4,723.53	√
	0649 21 1	STEEL MAST ARM ASSEMBLY, FURNISH AND INSTALL, SINGLE ARM 30'			EA	1.000	\$37,074.75	\$37,074.75	√
	0649 21 8	STEEL MAST ARM ASSEMBLY, FURNISH AND INSTALL, DOUBLE ARM 50'-40'			EA	1.000	\$68,558.03	\$68,558.03	√
	0649 21 13	STEEL MAST ARM ASSEMBLY, FURNISH AND INSTALL, DOUBLE ARM 60'-50'			EA	2.000	\$68,650.87	\$137,301.74	√
	0650 1 14	VEHICULAR TRAFFIC SIGNAL, FURNISH & INSTALL ALUMINUM, 3 SECTION, 1 WAY			AS	19.000	\$1,073.16	\$20,390.04	√
	0650 1 16	VEHICULAR TRAFFIC SIGNAL, FURNISH & INSTALL ALUMINUM, 4 SECTION, 1 WAY			AS	2.000	\$1,502.90	\$3,005.80	√
	0653 1 11	PEDESTRIAN SIGNAL, FURNISH & INSTALL LED COUNTDOWN, 1 WAY			AS	22.000	\$735.10	\$16,172.20	√
	0653 1 12	PEDESTRIAN SIGNAL, FURNISH & INSTALL LED COUNTDOWN, 2 WAYS			AS	1.000	\$1,282.12	\$1,282.12	√
	0660 2106	LOOP ASSEMBLY, F&I, TYPE F			AS	12.000	\$1,109.77	\$13,317.24	√
	0660 3 11	VEHICLE DETECTION SYSTEM-MICROWAVE, FURNISH & INSTALL CABINET EQUIPMENT			EA	1.000	\$5,800.83	\$5,800.83	√
	0660 3 12	VEHICLE DETECTION SYSTEM-MICROWAVE, FURNISH & INSTALL, ABOVE GROUND EQUIPMENT			EA	1.000	\$8,341.06	\$8,341.06	√
	0660 4 11	VEHICLE DETECTION SYSTEM- VIDEO, FURNISH & INSTALL CABINET EQUIPMENT			EA	1.000	\$15,014.85	\$15,014.85	√
	0660 4 12	VEHICLE DETECTION SYSTEM- VIDEO, FURNISH & INSTALL ABOVE GROUND EQUIPMENT			EA	4.000	\$4,627.55	\$18,510.20	√
	0663 1111	SIGNAL PRIORITY AND PREEMPTION SYSTEM, F&I, OPTICAL, CABINET ELECTRONICS			EA	1.000	\$6,102.64	\$6,102.64	√
	0663 1112	SIGNAL PRIORITY AND PREEMPTION SYSTEM, F&I, OPTICAL, DETECTOR			EA	2.000	\$1,773.33	\$3,546.66	√
	0665 1 11	PEDESTRIAN DETECTOR, FURNISH & INSTALL, STANDARD			EA	13.000	\$242.08	\$3,147.04	√
	0665 1 12	PEDESTRIAN DETECTOR, FURNISH & INSTALL, ACCESSIBLE			EA	11.000	\$1,379.61	\$15,175.71	√
	0665 1 60	PEDESTRIAN DETECTOR, REMOVE-POLE/PEDESTAL TO REMAIN			EA	1.000	\$53.68	\$53.68	√
	0670 5110	TRAFFIC CONTROLLER ASSEMBLY, F&I, NEMA			AS	2.000	\$32,850.72	\$65,701.44	√
	0670 5400	TRAFFIC CONTROLLER ASSEMBLY, MODIFY		P	AS	2.000	\$2,206.55	\$4,413.10	√
	0676 2111	ITS CABINET, FURNISH & INSTALL, POLE MOUNT, 336, 24" W X 36" H X 20" D			EA	2.000	\$6,710.00	\$13,420.00	√



Obs	Item Number	Item Description	Supplemental Description	T Spec	Unit	Quantity	Unit Price	Extended Amount	Low Cost
	0682 1113	ITS CCTV CAMERA, F&I, DOME PTZ ENCLOSURE - PRESSURIZED, IP, HIGH DEFINITION			EA	3.000	\$8,213.66	\$24,640.98	√
	0684 1 1	MANAGED FIELD ETHERNET SWITCH, FURNISH & INSTALL			EA	4.000	\$3,754.46	\$15,017.84	√
	0685 1 11	UNINTERRUPTIBLE POWER SUPPLY, FURNISH AND INSTALL, LINE INTERACTIVE			EA	3.000	\$5,571.98	\$16,715.94	√
	0685 1 13	UNINTERRUPTIBLE POWER SUPPLY, FURNISH AND INSTALL, LINE INTERACTIVE WITH CABINET			EA	2.000	\$8,302.03	\$16,604.06	√
	0695 1 1	TRAFFIC MONITORING SITE VEHICLE SENSOR-NON-WEIGHT, FURNISH & INSTALL			EA	4.000	\$1,497.73	\$5,990.92	√
	0695 6 12	TRAFFIC MONITORING SITE INDUCTIVE LOOP ASSEMBLY, FURNISH & INSTALL, 2 LOOPS			EA	4.000	\$1,511.92	\$6,047.68	√
	0695 7132	TRAFFIC MONITORING SITE CABINET, FURNISH & INSTALL, TYPE 3, PEDESTAL MOUNT			EA	1.000	\$5,580.92	\$5,580.92	√
	0695 8 11	TRAFFIC MONITORING SITE COMMUNICATIONS MODEM FURNISH & INSTALL			EA	1.000	\$5,441.27	\$5,441.27	√
	0700 1 11	SINGLE POST SIGN, F&I GROUND MOUNT, UP TO 12 SF			AS	20.000	\$399.87	\$7,997.40	√
	0700 1 13	SINGLE POST SIGN, F&I GROUND MOUNT, 21-30 SF			AS	5.000	\$1,802.75	\$9,013.75	√
	0700 1 31	SINGLE POST SIGN, F&I BRIDGE MOUNT INDEX 11870/700-012, UP TO 12 SF			AS	18.000	\$2,486.03	\$44,748.54	√
	0700 1 50	SINGLE POST SIGN, RELOCATE			AS	5.000	\$265.70	\$1,328.50	√
	0700 1 60	SINGLE POST SIGN, REMOVE			AS	45.000	\$37.54	\$1,689.30	√
	0700 2 50	MULTI- POST SIGN, GROUND MOUNT, RELOCATE			AS	1.000	\$4,345.79	\$4,345.79	√
	0700 3201	SIGN PANEL, FURNISH & INSTALL OVERHEAD MOUNT, UP TO 12 SF			EA	11.000	\$668.72	\$7,355.92	√
	0700 3204	SIGN PANEL, FURNISH & INSTALL OVERHEAD MOUNT, 31-50 SF			EA	2.000	\$1,858.89	\$3,717.78	√
	0700 3604	SIGN PANEL, REMOVE, 31-50 SF			EA	2.000	\$223.11	\$446.22	√
	0700 4610	OVERHEAD STATIC SIGN STRUCTURE, REMOVE CANTILEVER			EA	1.000	\$6,803.99	\$6,803.99	√
	0700 5 21	INTERNALLY ILLUMINATED SIGN, FURNISH & INSTALL OVERHEAD MOUNT, UP TO 12 SF			EA	2.000	\$3,090.68	\$6,181.36	√
	0700 5 22	INTERNALLY ILLUMINATED SIGN, FURNISH & INSTALL, OVERHEAD MOUNT, 12-18 SF			EA	2.000	\$3,373.48	\$6,746.96	√
	0710 90	PAINTED PAVEMENT MARKINGS, FINAL SURFACE	43372625201		LS	1.000	\$10,563.37	\$10,563.37	√

Obs	Item Number	Item Description	Supplemental Description	T Spec	Unit	Quantity	Unit Price	Extended Amount	Low Cost
	0711 11102	THERMOPLASTIC, STANDARD, WHITE, SOLID, 8" FOR INTERCHANGE AND URBAN ISLAND			GM	0.010	\$5,296.62	\$52.97	√
	0711 11123	THERMOPLASTIC, STANDARD, WHITE, SOLID, 12" FOR CROSSWALK AND ROUNDABOUT			LF	1087.000	\$2.66	\$2,891.42	√
	0711 11125	THERMOPLASTIC, STANDARD, WHITE, SOLID, 24" FOR STOP LINE AND CROSSWALK			LF	1295.000	\$5.09	\$6,591.55	√
	0711 11141	THERMOPLASTIC, STANDARD, WHITE, 2-4 DOTTED GUIDELINE/ 6-10 GAP EXTENSION, 6"			GM	0.110	\$1,439.43	\$158.34	√
	0711 11160	THERMOPLASTIC, STANDARD, WHITE, MESSAGE OR SYMBOL			EA	28.000	\$106.28	\$2,975.84	√
	0711 11170	THERMOPLASTIC, STANDARD, WHITE, ARROW			EA	30.000	\$61.34	\$1,840.20	√
	0711 16101	THERMOPLASTIC, STANDARD-OTHER SURFACES, WHITE, SOLID, 6"			GM	1.170	\$4,352.50	\$5,092.43	√
	0711 16131	THERMOPLASTIC, STANDARD-OTHER SURFACES, WHITE, SKIP, 6",10-30 SKIP OR 3-9 LANE DROP			GM	0.160	\$1,308.41	\$209.35	√
	0711 16231	THERMOPLASTIC, STANDARD-OTHER SURFACES, YELLOW, SKIP, 6"			GM	1.020	\$1,306.64	\$1,332.77	√
	0711 17 1	THERMOPLASTIC, REMOVE EXISTING THERMOPLASTIC PAVEMENT MARKINGS-SURFACE TO REMAIN			SF	166.000	\$2.43	\$403.38	√
	0713103101	PERMANENT TAPE, WHITE, SOLID, 6" FOR CONCRETE BRIDGES			GM	0.690	\$29,718.66	\$20,505.88	√
	0713103201	PERMANENT TAPE, YELLOW, SOLID, 6" FOR CONCRETE BRIDGES			GM	1.050	\$29,858.94	\$31,351.89	√
	0713103231	PERMANENT TAPE, YELLOW, 10-30 SKIP/ 3-9 DOTTED, 6" FOR CONCRETE SURFACES			GM	0.260	\$7,336.75	\$1,907.56	√
	0713103331	PERMANENT TAPE, BLACK, SKIP/DOTTED, 6" FOR CONCRETE SURFACES			GM	4.240	\$7,234.27	\$30,673.30	√
	0715 1 12	LIGHTING CONDUCTORS, F&I, INSULATED, NO.8 - 6			LF	24212.000	\$2.29	\$55,445.48	√
	0715 1 60	LIGHTING CONDUCTORS, REMOVE & DISPOSE, CONTRACTOR OWNS			LF	11150.000	\$0.40	\$4,460.00	√
	0715 4 11	LIGHT POLE COMPLETE, FURNISH & INSTALL STANDARD POLE STANDARD FOUNDATION, 30' MOUNTING HEIGHT			EA	3.000	\$5,944.29	\$17,832.87	√
	0715 4 13	LIGHT POLE COMPLETE, FURNISH & INSTALL STANDARD POLE STANDARD FOUNDATION, 40' MOUNTING HEIGHT			EA	29.000	\$6,733.42	\$195,269.18	√
	0715 5 31	LUMINAIRE & BRACKET ARM- ALUMINUM, FURNISH & INSTALL NEW LUMINAIRE AND ARM ON NEW/EXISTING POLE			EA	5.000	\$2,747.64	\$13,738.20	√
	0715 7 11	LOAD CENTER, F&I, SECONDARY VOLTAGE			EA	3.000	\$15,555.97	\$46,667.91	√

Obs	Item Number	Item Description	Supplemental Description	T Spec	Unit	Quantity	Unit Price	Extended Amount	Low Cost
	0715 7 41	LOAD CENTER, REMOVE, SECONDARY VOLTAGE			EA	3.000	\$814.66	\$2,443.98	√
	0715 11125	LUMINAIRE, F&I, UNDER DECK, WALL MOUNT			EA	7.000	\$1,530.30	\$10,712.10	√
	0715 11128	LUMINAIRE, F&I, UNDER DECK, FLOOD			EA	1.000	\$1,145.63	\$1,145.63	√
	0715 11211	LUMINAIRE, F&I- REPLACE EXISTING LUMINAIRE ON EXISTING POLE/ARM, ROADWAY, COBRA HEAD			EA	30.000	\$1,286.70	\$38,601.00	√
	0715 21 2	LIGHTING REPAIRS AND RETROFITS, LED RETROFIT KIT FOR EXISTING LUMINAIRE		P	EA	3.000	\$1,309.66	\$3,928.98	√
	0999 25	INITIAL CONTINGENCY AMOUNT, DO NOT BID	43372625201		LS	1.000	\$54,351.00	\$54,351.00	√
							Total:	\$5,489,592.05	

Project Name: SR 865 (SAN CARLOS) FROM N  
CRESCENT ST TO N OF HURRICANE PASS  
BRIDGE - INTERSECTION IMPROVEMENT

County: 12 - LEE

Federal Aid: N/A

Letting Date: 2/22/2023 12:00:00 AM

District: 01

Project Work Type: X4 - Widening & Resurfacing

**Project Alternate Summary**

Alternate Description	Category Alternate Set	Category Alternate Member	Item Alternate Member	Item Alternate Member	Total	Low Cost
					\$5,489,592.05	√

Project Detail

Project Number: 43372625201

Category: 0100 Structures

Obs	Item Number	Item Description	Supplemental Description	T Spec	Fund	Unit	Quantity	Unit Price	Extended Amount	Low Cost
	0108 1	MONITOR EXISTING STRUCTURES-INSPECTION AND SETTLEMENT MONITORING	43372625201	P		LS	1.00	\$15,000.00	\$15,000.00	√
	0110 3	REMOVAL OF EXISTING STRUCTURES/BRIDGES	43372625201			LS - SF	2143.00	\$45.25	\$96,970.75	√
	0400 4 4	CONCRETE CLASS IV, SUPERSTRUCTURE				CY	380.40	\$988.71	\$376,105.28	√
	0415 1 4	REINFORCING STEEL - BRIDGE SUPERSTRUCTURE				LB	13240.00	\$1.20	\$15,888.00	√
	0458 1 11	BRIDGE DECK EXPANSION JOINT, NEW CONSTRUCTION, F&I POURED JOINT WITH BACKER ROD				LF	532.00	\$56.93	\$30,286.76	√
	0460 71 2	METAL TRAFFIC RAILING, STEEL POST AND RAIL		A		LF	2143.00	\$115.47	\$247,452.21	√
0100 Structures Total									\$781,703.00	

Project Number: 43372625201

Category: 0101 Structures

Obs	Item Number	Item Description	Supplemental Description	T Spec	Fund	Unit	Quantity	Unit Price	Extended Amount	Low Cost
	0400 4 4	CONCRETE CLASS IV, SUPERSTRUCTURE				CY	46.00	\$988.71	\$45,480.66	√
	0415 1 4	REINFORCING STEEL - BRIDGE SUPERSTRUCTURE				LB	10177.00	\$1.20	\$12,212.40	√
	0458 1 21	BRIDGE DECK EXPANSION JOINT, REHABILITATION, POURED JOINT WITH BACKER ROD				LF	810.00	\$63.21	\$51,200.10	√
	0515 4 1	BULLET RAIL, SINGLE RAIL				LF	390.00	\$58.91	\$22,974.90	√
0101 Structures Total									\$131,868.06	

Project Number: 43372625201

Category: 0200 Roadway

Obs	Item Number	Item Description	Supplemental Description	T Spec	Fund	Unit	Quantity	Unit Price	Extended Amount	Low Cost
	0101 1	MOBILIZATION	43372625201			LS	1.00	\$448,781.00	\$448,781.00	√
	0102 1	MAINTENANCE OF TRAFFIC	43372625201			LS - DA	1.00	\$411,726.00	\$411,726.00	√
	0102 60	WORK ZONE SIGN				ED	6670.00	\$0.24	\$1,600.80	√
	0102 71 15	TEMPORARY BARRIER, F&I, ANCHORED				LF	2453.00	\$27.87	\$68,365.11	√
	0102 74 1	CHANNELIZING DEVICE- TYPES I, II, DI, VP, DRUM, OR LCD				ED	8100.00	\$0.10	\$810.00	√
	0102 99	PORTABLE CHANGEABLE MESSAGE SIGN, TEMPORARY				ED	172.00	\$10.82	\$1,861.04	√
	0102115	TYPE III BARRICADE				ED	480.00	\$0.29	\$139.20	√
	0102913 21	REMOVABLE TAPE, WHITE, SOLID 6"				GM	1.40	\$9,858.40	\$13,801.76	√
	0102913 31	REMOVABLE TAPE, YELLOW, SOLID, 6"				GM	1.18	\$9,553.97	\$11,273.68	√
	0104 10 3	SEDIMENT BARRIER				LF	1113.00	\$1.65	\$1,836.45	√
	0104 18	INLET PROTECTION SYSTEM				EA	16.00	\$114.43	\$1,830.88	√
	0107 1	LITTER REMOVAL			N	AC	4.69	\$32.25	\$151.25	√
	0107 2	MOWING			N	AC	0.80	\$62.44	\$49.95	√
	0110 1 1	CLEARING & GRUBBING	43372625201			LS - AC	0.44	\$66,617.51	\$29,311.70	√
	0110 4 10	REMOVAL OF EXISTING CONCRETE				SY	1755.00	\$23.64	\$41,488.20	√
	0120 1	REGULAR EXCAVATION				CY	3825.00	\$9.94	\$38,020.50	√
	0120 6	EMBANKMENT				CY	2389.00	\$14.55	\$34,759.95	√
	0160 4	TYPE B STABILIZATION				SY	1350.00	\$23.44	\$31,644.00	√
	0285710	OPTIONAL BASE, BASE GROUP 10				SY	1752.00	\$29.17	\$51,105.84	√
	0327 70 5	MILLING EXISTING ASPHALT PAVEMENT, 2" AVG DEPTH				SY	24078.00	\$3.08	\$74,160.24	√
	0327 70 6	MILLING EXISTING ASPHALT PAVEMENT, 1 1/2" AVG DEPTH				SY	803.00	\$7.84	\$6,295.52	√
	0334 1 13	SUPERPAVE ASPHALTIC CONC, TRAFFIC C				TN	174.00	\$192.25	\$33,451.50	√
	0337 7 83	ASPHALT CONCRETE FRICTION COURSE, TRAFFIC C, FC-12.5, PG 76-22				TN	2898.00	\$131.47	\$381,000.06	√
	0400 0 11	CONCRETE CLASS NS, GRAVITY WALL INDEX 400-011				CY	160.00	\$913.40	\$146,144.00	√
	0425 1203	INLETS, CURB, TYPE 9, J BOT, <10'				EA	1.00	\$8,660.63	\$8,660.63	√
	0425 1321	INLETS, CURB, TYPE P-2, <10'				EA	1.00	\$8,495.94	\$8,495.94	√
	0425 1361	INLETS, CURB, TYPE P-6, <10'				EA	1.00	\$6,127.18	\$6,127.18	√
	0425 1525	INLETS, DITCH BOTTOM, TYPE C, PARTIAL				EA	1.00	\$3,703.41	\$3,703.41	√
	0425 1711	INLETS, GUTTER, TYPE V, <10'				EA	3.00	\$5,286.59	\$15,859.77	√
	0425 2 41	MANHOLES, P-7, <10'				EA	2.00	\$4,594.61	\$9,189.22	√
	0425 2 43	MANHOLES, P-7, PARTIAL				EA	1.00	\$2,940.75	\$2,940.75	√

Obs	Item Number	Item Description	Supplemental Description	T Spec	Fund	Unit	Quantity	Unit Price	Extended Amount	Low Cost
	0425 2 91	MANHOLES, J-8, <10'				EA	1.00	\$8,397.49	\$8,397.49	√
	0425 2 93	MANHOLES, J-8, PARTIAL				EA	1.00	\$4,750.03	\$4,750.03	√
	0425 11	MODIFY EXISTING DRAINAGE STRUCTURE		P		EA	2.00	\$7,390.72	\$14,781.44	√
	0430174112	PIPE CULVERT, OPTIONAL MATERIAL, ROUND, 12"SD				LF	8.00	\$166.31	\$1,330.48	√
	0430174115	PIPE CULVERT, OPTIONAL MATERIAL, ROUND, 15"SD				LF	153.00	\$65.59	\$10,035.27	√
	0430174118	PIPE CULVERT, OPTIONAL MATERIAL, ROUND, 18"SD				LF	42.00	\$112.95	\$4,743.90	√
	0430174124	PIPE CULVERT, OPTIONAL MATERIAL, ROUND, 24"SD				LF	8.00	\$174.59	\$1,396.72	√
	0436 1 1	TRENCH DRAIN, STANDARD				LF	288.00	\$292.92	\$84,360.96	√
	0515 1 2	PIPE HANDRAIL - GUIDERAIL, ALUMINUM				LF	40.00	\$64.17	\$2,566.80	√
	0515 4 2	BULLET RAIL, DOUBLE RAIL				LF	207.00	\$57.18	\$11,836.26	√
	0520 1 7	CONCRETE CURB & GUTTER, TYPE E				LF	696.00	\$27.52	\$19,153.92	√
	0520 1 10	CONCRETE CURB & GUTTER, TYPE F				LF	2191.00	\$31.34	\$68,665.94	√
	0520 2 4	CONCRETE CURB, TYPE D				LF	562.00	\$27.94	\$15,702.28	√
	0520 2 8	CONCRETE CURB, TYPE RA				LF	266.00	\$37.53	\$9,982.98	√
	0520 70	CONCRETE TRAFFIC SEPARATOR, SPECIAL-VARIABLE WIDTH		P		SY	180.00	\$99.51	\$17,911.80	√
	0521 72 43	SHOULDER CONCRETE BARRIER, CURB AND GUTTER BARRIER				LF	716.00	\$267.99	\$191,880.84	√
	0521 72 44	SHOULDER CONCRETE BARRIER, 44" PIER PROTECTION BARRIER/CRASH WALL				LF	160.00	\$441.59	\$70,654.40	√
	0522 1	CONCRETE SIDEWALK AND DRIVEWAYS, 4" THICK				SY	1703.00	\$53.15	\$90,514.45	√
	0522 2	CONCRETE SIDEWALK AND DRIVEWAYS, 6" THICK				SY	784.00	\$58.11	\$45,558.24	√
	0527 2	DETECTABLE WARNINGS				SF	382.00	\$33.27	\$12,709.14	√
	0550 10222	FENCING, TYPE B, 5.1-6.0, W/ VINYL COATING				LF	675.00	\$25.32	\$17,091.00	√
	0550 60623	FENCE GATE, TYPE B VINYL, DOUBLE, 12.1-18.0' OPENING				EA	2.00	\$2,520.00	\$5,040.00	√
	0570 1 2	PERFORMANCE TURF, SOD				SY	1973.00	\$4.60	\$9,075.80	√
	0999 25	INITIAL CONTINGENCY AMOUNT, DO NOT BID	43372625201		N	LS	1.00	\$54,351.00	\$54,351.00	√
0200 Roadway Total									\$2,657,076.67	

Project Number: 43372625201

Category: 0300 Signing

Obs	Item Number	Item Description	Supplemental Description	T Spec	Fund	Unit	Quantity	Unit Price	Extended Amount	Low Cost
	0700 1 11	SINGLE POST SIGN, F&I GROUND MOUNT, UP TO 12 SF				AS	20.00	\$399.87	\$7,997.40	√
	0700 1 13	SINGLE POST SIGN, F&I GROUND MOUNT, 21-30 SF				AS	5.00	\$1,802.75	\$9,013.75	√
	0700 1 31	SINGLE POST SIGN, F&I BRIDGE MOUNT INDEX 11870/700-012, UP TO 12 SF				AS	18.00	\$2,486.03	\$44,748.54	√
	0700 1 50	SINGLE POST SIGN, RELOCATE				AS	5.00	\$265.70	\$1,328.50	√
	0700 1 60	SINGLE POST SIGN, REMOVE				AS	45.00	\$37.54	\$1,689.30	√
	0700 2 50	MULTI- POST SIGN, GROUND MOUNT, RELOCATE				AS	1.00	\$4,345.79	\$4,345.79	√
	0700 3201	SIGN PANEL, FURNISH & INSTALL OVERHEAD MOUNT, UP TO 12 SF				EA	11.00	\$668.72	\$7,355.92	√
	0700 3204	SIGN PANEL, FURNISH & INSTALL OVERHEAD MOUNT, 31-50 SF				EA	2.00	\$1,858.89	\$3,717.78	√
	0700 3604	SIGN PANEL, REMOVE, 31-50 SF				EA	2.00	\$223.11	\$446.22	√
	0700 4610	OVERHEAD STATIC SIGN STRUCTURE, REMOVE CANTILEVER				EA	1.00	\$6,803.99	\$6,803.99	√
	0700 5 21	INTERNALLY ILLUMINATED SIGN, FURNISH & INSTALL OVERHEAD MOUNT, UP TO 12 SF				EA	2.00	\$3,090.68	\$6,181.36	√
	0700 5 22	INTERNALLY ILLUMINATED SIGN, FURNISH & INSTALL, OVERHEAD MOUNT, 12-18 SF				EA	2.00	\$3,373.48	\$6,746.96	√
	0710 90	PAINTED PAVEMENT MARKINGS, FINAL SURFACE	43372625201			LS	1.00	\$10,563.37	\$10,563.37	√
	0711 11102	THERMOPLASTIC, STANDARD, WHITE, SOLID, 8" FOR INTERCHANGE AND URBAN ISLAND				GM	0.01	\$5,296.62	\$52.97	√
	0711 11123	THERMOPLASTIC, STANDARD, WHITE, SOLID, 12" FOR CROSSWALK AND ROUNDABOUT				LF	1087.00	\$2.66	\$2,891.42	√
	0711 11125	THERMOPLASTIC, STANDARD, WHITE, SOLID, 24" FOR STOP LINE AND CROSSWALK				LF	1295.00	\$5.09	\$6,591.55	√
	0711 11141	THERMOPLASTIC, STANDARD, WHITE, 2-4 DOTTED GUIDELINE/ 6-10 GAP EXTENSION, 6"				GM	0.11	\$1,439.43	\$158.34	√
	0711 11160	THERMOPLASTIC, STANDARD, WHITE, MESSAGE OR SYMBOL				EA	28.00	\$106.28	\$2,975.84	√
	0711 11170	THERMOPLASTIC, STANDARD, WHITE, ARROW				EA	30.00	\$61.34	\$1,840.20	√
	0711 16101	THERMOPLASTIC, STANDARD-OTHER SURFACES, WHITE, SOLID, 6"				GM	1.17	\$4,352.50	\$5,092.43	√
	0711 16131	THERMOPLASTIC, STANDARD-OTHER SURFACES, WHITE, SKIP, 6",10-30 SKIP OR 3 -9 LANE DROP				GM	0.16	\$1,308.41	\$209.35	√
	0711 16231	THERMOPLASTIC, STANDARD-OTHER SURFACES, YELLOW, SKIP, 6"				GM	1.02	\$1,306.64	\$1,332.77	√



Obs	Item Number	Item Description	Supplemental Description	T Spec	Fund	Unit	Quantity	Unit Price	Extended Amount	Low Cost
	0711 17 1	THERMOPLASTIC, REMOVE EXISTING THERMOPLASTIC PAVEMENT MARKINGS-SURFACE TO REMAIN				SF	166.00	\$2.43	\$403.38	√
	0713103101	PERMANENT TAPE, WHITE, SOLID, 6" FOR CONCRETE BRIDGES				GM	0.69	\$29,718.66	\$20,505.88	√
	0713103201	PERMANENT TAPE, YELLOW, SOLID, 6" FOR CONCRETE BRIDGES				GM	1.05	\$29,858.94	\$31,351.89	√
	0713103231	PERMANENT TAPE, YELLOW, 10-30 SKIP/ 3-9 DOTTED, 6" FOR CONCRETE SURFACES				GM	0.13	\$7,336.75	\$953.78	√
	0713103231	PERMANENT TAPE, YELLOW, 10-30 SKIP/ 3-9 DOTTED, 6" FOR CONCRETE SURFACES				GM	0.13	\$7,336.75	\$953.78	√
	0713103331	PERMANENT TAPE, BLACK, SKIP/DOTTED, 6" FOR CONCRETE SURFACES				GM	2.12	\$7,234.27	\$15,336.65	√
	0713103331	PERMANENT TAPE, BLACK, SKIP/DOTTED, 6" FOR CONCRETE SURFACES				GM	2.12	\$7,234.27	\$15,336.65	√
0300 Signing Total									\$216,925.76	

Project Number: 43372625201

Category: 0400 Lighting

Obs	Item Number	Item Description	Supplemental Description	T Spec	Fund	Unit	Quantity	Unit Price	Extended Amount	Low Cost
	0630 2 11	CONDUIT, FURNISH & INSTALL, OPEN TRENCH				LF	4957.00	\$12.92	\$64,044.44	√
	0630 2 12	CONDUIT, FURNISH & INSTALL, DIRECTIONAL BORE				LF	400.00	\$25.68	\$10,272.00	√
	0630 2 15	CONDUIT, FURNISH & INSTALL, BRIDGE MOUNT				LF	475.00	\$34.53	\$16,401.75	√
	0630 2 65	CONDUIT, REMOVE, BRIDGE MOUNT				LF	505.00	\$5.80	\$2,929.00	√
	0635 2 11	PULL & SPLICE BOX, F&I, 13" x 24" COVER SIZE				EA	39.00	\$820.27	\$31,990.53	√
	0715 1 12	LIGHTING CONDUCTORS, F&I, INSULATED, NO.8 - 6				LF	24212.00	\$2.29	\$55,445.48	√
	0715 1 60	LIGHTING CONDUCTORS, REMOVE & DISPOSE, CONTRACTOR OWNS				LF	11150.00	\$0.40	\$4,460.00	√
	0715 4 11	LIGHT POLE COMPLETE, FURNISH & INSTALL STANDARD POLE STANDARD FOUNDATION, 30' MOUNTING HEIGHT				EA	3.00	\$5,944.29	\$17,832.87	√
	0715 4 13	LIGHT POLE COMPLETE, FURNISH & INSTALL STANDARD POLE STANDARD FOUNDATION, 40' MOUNTING HEIGHT				EA	29.00	\$6,733.42	\$195,269.18	√
	0715 5 31	LUMINAIRE & BRACKET ARM- ALUMINUM, FURNISH & INSTALL NEW LUMINAIRE AND ARM ON NEW/EXISTING POLE				EA	5.00	\$2,747.64	\$13,738.20	√
	0715 7 11	LOAD CENTER, F&I, SECONDARY VOLTAGE				EA	3.00	\$15,555.97	\$46,667.91	√

Obs	Item Number	Item Description	Supplemental Description	T Spec	Fund	Unit	Quantity	Unit Price	Extended Amount	Low Cost
	0715 7 41	LOAD CENTER, REMOVE, SECONDARY VOLTAGE				EA	3.00	\$814.66	\$2,443.98	√
	0715 11125	LUMINAIRE, F&I, UNDER DECK, WALL MOUNT				EA	7.00	\$1,530.30	\$10,712.10	√
	0715 11128	LUMINAIRE, F&I, UNDER DECK, FLOOD				EA	1.00	\$1,145.63	\$1,145.63	√
	0715 11211	LUMINAIRE, F&I- REPLACE EXISTING LUMINAIRE ON EXISTING POLE/ARM, ROADWAY, COBRA HEAD				EA	30.00	\$1,286.70	\$38,601.00	√
	0715 21 2	LIGHTING REPAIRS AND RETROFITS, LED RETROFIT KIT FOR EXISTING LUMINAIRE		P		EA	3.00	\$1,309.66	\$3,928.98	√
0400 Lighting Total									\$515,883.05	

Project Number: 43372625201

Category: 0500 Signalization

Obs	Item Number	Item Description	Supplemental Description	T Spec	Fund	Unit	Quantity	Unit Price	Extended Amount	Low Cost
	0630 2 11	CONDUIT, FURNISH & INSTALL, OPEN TRENCH				LF	928.00	\$12.93	\$11,999.04	√
	0630 2 12	CONDUIT, FURNISH & INSTALL, DIRECTIONAL BORE				LF	935.00	\$25.68	\$24,010.80	√
	0632 7 1	SIGNAL CABLE- NEW OR RECONSTRUCTED INTERSECTION, FURNISH & INSTALL				PI	3.00	\$7,357.31	\$22,071.93	√
	0634 4600	SPAN WIRE ASSEMBLY, REMOVE- POLES REMAIN				PI	2.00	\$1,560.06	\$3,120.12	√
	0635 2 11	PULL & SPLICE BOX, F&I, 13" x 24" COVER SIZE				EA	58.00	\$820.16	\$47,569.28	√
	0639 1122	ELECTRICAL POWER SERVICE, F&I, UNDERGROUND, METER PURCHASED BY CONTRACTOR				AS	2.00	\$3,225.72	\$6,451.44	√
	0639 2 1	ELECTRICAL SERVICE WIRE, FURNISH & INSTALL				LF	425.00	\$7.54	\$3,204.50	√
	0639 3 11	ELECTRICAL SERVICE DISCONNECT, F&I, POLE MOUNT				EA	2.00	\$1,446.93	\$2,893.86	√
	0641 2 11	PRESTRESSED CONCRETE POLE, F&I, TYPE P-II PEDESTAL				EA	1.00	\$1,703.45	\$1,703.45	√
	0641 2 12	PRESTRESSED CONCRETE POLE, F&I, TYPE P-II SERVICE POLE				EA	3.00	\$1,657.54	\$4,972.62	√
	0641 2 13	PRESTRESSED CONCRETE POLE, F&I, TYPE P-III				EA	2.00	\$8,634.97	\$17,269.94	√
	0646 1 11	ALUMINUM SIGNALS POLE, PEDESTAL				EA	23.00	\$1,615.94	\$37,166.62	√
	0646 1 12	ALUMINUM SIGNALS POLE, FURNISH & INSTALL PEDESTRIAN DETECTOR POST				EA	3.00	\$1,574.51	\$4,723.53	√

Obs	Item Number	Item Description	Supplemental Description	T Spec	Fund	Unit	Quantity	Unit Price	Extended Amount	Low Cost
	0649 21 1	STEEL MAST ARM ASSEMBLY, FURNISH AND INSTALL, SINGLE ARM 30'				EA	1.00	\$37,074.75	\$37,074.75	√
	0649 21 8	STEEL MAST ARM ASSEMBLY, FURNISH AND INSTALL, DOUBLE ARM 50'-40'				EA	1.00	\$68,558.03	\$68,558.03	√
	0649 21 13	STEEL MAST ARM ASSEMBLY, FURNISH AND INSTALL, DOUBLE ARM 60'-50'				EA	2.00	\$68,650.87	\$137,301.74	√
	0650 1 14	VEHICULAR TRAFFIC SIGNAL, FURNISH & INSTALL ALUMINUM, 3 SECTION, 1 WAY				AS	19.00	\$1,073.16	\$20,390.04	√
	0650 1 16	VEHICULAR TRAFFIC SIGNAL, FURNISH & INSTALL ALUMINUM, 4 SECTION, 1 WAY				AS	2.00	\$1,502.90	\$3,005.80	√
	0653 1 11	PEDESTRIAN SIGNAL, FURNISH & INSTALL LED COUNTDOWN, 1 WAY				AS	22.00	\$735.10	\$16,172.20	√
	0653 1 12	PEDESTRIAN SIGNAL, FURNISH & INSTALL LED COUNTDOWN, 2 WAYS				AS	1.00	\$1,282.12	\$1,282.12	√
	0660 2106	LOOP ASSEMBLY, F&I, TYPE F				AS	12.00	\$1,109.77	\$13,317.24	√
	0660 4 11	VEHICLE DETECTION SYSTEM- VIDEO, FURNISH & INSTALL CABINET EQUIPMENT				EA	1.00	\$15,014.85	\$15,014.85	√
	0660 4 12	VEHICLE DETECTION SYSTEM- VIDEO, FURNISH & INSTALL ABOVE GROUND EQUIPMENT				EA	4.00	\$4,627.55	\$18,510.20	√
	0663 1111	SIGNAL PRIORITY AND PREEMPTION SYSTEM, F&I, OPTICAL, CABINET ELECTRONICS				EA	1.00	\$6,102.64	\$6,102.64	√
	0663 1112	SIGNAL PRIORITY AND PREEMPTION SYSTEM, F&I, OPTICAL, DETECTOR				EA	2.00	\$1,773.33	\$3,546.66	√
	0665 1 11	PEDESTRIAN DETECTOR, FURNISH & INSTALL, STANDARD				EA	13.00	\$242.08	\$3,147.04	√
	0665 1 12	PEDESTRIAN DETECTOR, FURNISH & INSTALL, ACCESSIBLE				EA	11.00	\$1,379.61	\$15,175.71	√
	0665 1 60	PEDESTRIAN DETECTOR, REMOVE-POLE/PEDESTAL TO REMAIN				EA	1.00	\$53.68	\$53.68	√
	0670 5110	TRAFFIC CONTROLLER ASSEMBLY, F&I, NEMA				AS	2.00	\$32,850.72	\$65,701.44	√
	0670 5400	TRAFFIC CONTROLLER ASSEMBLY, MODIFY		P		AS	2.00	\$2,206.55	\$4,413.10	√
	0685 1 13	UNINTERRUPTIBLE POWER SUPPLY, FURNISH AND INSTALL, LINE INTERACTIVE WITH CABINET				EA	2.00	\$8,302.03	\$16,604.06	√
	0695 1 1	TRAFFIC MONITORING SITE VEHICLE SENSOR-NON-WEIGHT, FURNISH & INSTALL				EA	4.00	\$1,497.73	\$5,990.92	√
	0695 6 12	TRAFFIC MONITORING SITE INDUCTIVE LOOP ASSEMBLY, FURNISH & INSTALL, 2 LOOPS				EA	4.00	\$1,511.92	\$6,047.68	√
	0695 7132	TRAFFIC MONITORING SITE CABINET, FURNISH & INSTALL, TYPE 3, PEDESTAL MOUNT				EA	1.00	\$5,580.92	\$5,580.92	√

Obs	Item Number	Item Description	Supplemental Description	T Spec	Fund	Unit	Quantity	Unit Price	Extended Amount	Low Cost
	0695 8 11	TRAFFIC MONITORING SITE COMMUNICATIONS MODEM FURNISH & INSTALL				EA	1.00	\$5,441.27	\$5,441.27	√
0500 Signalization Total									\$655,589.22	

Project Number: 43372625201

Category: 0550 Intelligent Transportation System

Obs	Item Number	Item Description	Supplemental Description	T Spec	Fund	Unit	Quantity	Unit Price	Extended Amount	Low Cost
	0630 2 11	CONDUIT, FURNISH & INSTALL, OPEN TRENCH				LF	107.00	\$12.94	\$1,384.58	√
	0630 2 12	CONDUIT, FURNISH & INSTALL, DIRECTIONAL BORE				LF	10966.00	\$25.65	\$281,277.90	√
	0630 2 14	CONDUIT, FURNISH & INSTALL, ABOVEGROUND				LF	15.00	\$33.70	\$505.50	√
	0633 1121	FIBER OPTIC CABLE, F&I, UNDERGROUND,2-12 FIBERS				LF	1073.00	\$3.23	\$3,465.79	√
	0633 1123	FIBER OPTIC CABLE, F&I, UNDERGROUND,49-96 FIBERS				LF	16655.00	\$3.63	\$60,457.65	√
	0633 2 31	FIBER OPTIC CONNECTION, INSTALL, SPLICE				EA	242.00	\$43.87	\$10,616.54	√
	0633 2 32	FIBER OPTIC CONNECTION, INSTALL, TERMINATION				EA	84.00	\$101.73	\$8,545.32	√
	0633 3 11	FIBER OPTIC CONNECTION HARDWARE, F&I, SPLICE ENCLOSURE				EA	7.00	\$948.41	\$6,638.87	√
	0633 3 14	FIBER OPTIC CONNECTION HARDWARE, F&I, BUFFER TUBE FAN OUT KIT				EA	7.00	\$97.36	\$681.52	√
	0633 3 16	FIBER OPTIC CONNECTION HARDWARE, F&I, PATCH PANEL- FIELD TERMINATED				EA	5.00	\$870.85	\$4,354.25	√
	0633 3 51	FIBER OPTIC CONNECTION HARDWARE, ADJUST/MODIFY SPLICE ENCLOSURE				EA	1.00	\$555.99	\$555.99	√
	0635 2 11	PULL & SPLICE BOX, F&I, 13" x 24" COVER SIZE				EA	7.00	\$820.49	\$5,743.43	√
	0635 2 12	PULL & SPLICE BOX, F&I, 24" X 36" COVER SIZE				EA	16.00	\$1,603.05	\$25,648.80	√
	0635 2 13	PULL & SPLICE BOX, F&I, 30" X 60" RECTANGULAR OR 36" ROUND COVER SIZE				EA	7.00	\$3,386.58	\$23,706.06	√
	0639 1121	ELECTRICAL POWER SERVICE, F&I, UNDERGROUND, METER FURNISHED BY POWER COMPANY				AS	2.00	\$3,140.32	\$6,280.64	√
	0639 2 1	ELECTRICAL SERVICE WIRE, FURNISH & INSTALL				LF	511.00	\$7.54	\$3,852.94	√
	0639 3 11	ELECTRICAL SERVICE DISCONNECT, F&I, POLE MOUNT				EA	2.00	\$1,446.93	\$2,893.86	√

Obs	Item Number	Item Description	Supplemental Description	T Spec	Fund	Unit	Quantity	Unit Price	Extended Amount	Low Cost
	0660 3 11	VEHICLE DETECTION SYSTEM-MICROWAVE, FURNISH & INSTALL CABINET EQUIPMENT				EA	1.00	\$5,800.83	\$5,800.83	√
	0660 3 12	VEHICLE DETECTION SYSTEM-MICROWAVE, FURNISH & INSTALL, ABOVE GROUND EQUIPMENT				EA	1.00	\$8,341.06	\$8,341.06	√
	0676 2111	ITS CABINET, FURNISH & INSTALL, POLE MOUNT, 336, 24" W X 36" H X 20" D				EA	2.00	\$6,710.00	\$13,420.00	√
	0682 1113	ITS CCTV CAMERA, F&I, DOME PTZ ENCLOSURE - PRESSURIZED, IP, HIGH DEFINITION				EA	3.00	\$8,213.66	\$24,640.98	√
	0684 1 1	MANAGED FIELD ETHERNET SWITCH, FURNISH & INSTALL				EA	4.00	\$3,754.46	\$15,017.84	√
	0685 1 11	UNINTERRUPTIBLE POWER SUPPLY, FURNISH AND INSTALL, LINE INTERACTIVE				EA	3.00	\$5,571.98	\$16,715.94	√
0550 Intelligent Transportation System Total									\$530,546.29	

**Project Alternate Summary for 43372625201**

Alternate Description	Category Alternate Set	Category Alternate Member	Item Alternate Member	Item Alternate Member	Total	Low Cost
					\$5,489,592.05	√

***APPENDIX C***  
***DRAFT TYPICAL SECTION PACKAGE***

---

*STATE OF FLORIDA*  
*DEPARTMENT OF TRANSPORTATION*

*TYPICAL SECTION PACKAGE*

FINANCIAL PROJECT ID 433726-2-32-01

(FEDERAL FUNDS)

LEE COUNTY (12004)

STATE ROAD NO. 865 (SAN CARLOS BOULEVARD)

FDOT DISTRICT DESIGN ENGINEER

FDOT DISTRICT TRAFFIC OPERATIONS ENGINEER

CONCURRING WITH:  
TYPICAL SECTION ELEMENTS  
TARGET SPEED  
DESIGN & POSTED SPEEDS

CONCURRING WITH:  
TARGET SPEED  
DESIGN & POSTED SPEEDS

FDOT DISTRICT INTERMODAL SYSTEMS DEVELOPMENT MANAGER

FDOT DISTRICT STRUCTURES DESIGN ENGINEER

CONCURRING WITH:  
CONTEXT CLASSIFICATION  
TARGET SPEED

CONCURRING WITH:  
TYPICAL SECTION ELEMENTS

NOT USED

NOT USED

CONCURRING WITH:

CONCURRING WITH:

NOT USED

NOT USED

CONCURRING WITH:

CONCURRING WITH:

PROJECT LOCATION URL: [https://owpstandardmap.fdot.gov/query=WorkProgram\\_Tbl15Dissolved\\_2004,\\_itemseg,4337262](https://owpstandardmap.fdot.gov/query=WorkProgram_Tbl15Dissolved_2004,_itemseg,4337262)

PROJECT DESCRIPTION: NEW CONSTRUCTION / RECONSTRUCTION

PROJECT LIMITS: BEGIN MP 0.000 - END MP 1.078

EXCEPTIONS: SHARED USE PATH WIDTH  
SHOULDER WIDTH  
BICYCLE LANE WIDTH  
SIDEWALK WIDTH  
AUXILIARY LANE WIDTH

BRIDGE LIMITS: (120088) MP 0.076 - MP 0.474  
(120089) MP 0.885 - MP 0.952

RAILROAD CROSSING: NONE

APPROVED BY:

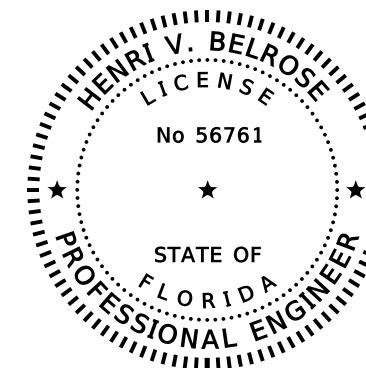

THIS ITEM HAS BEEN DIGITALLY SIGNED AND SEALED BY:

ON THE DATE ADJACENT TO THE SEAL  
PRINTED COPIES OF THIS DOCUMENT ARE NOT CONSIDERED SIGNED AND SEALED AND THE SIGNATURE MUST BE VERIFIED ON ANY ELECTRONIC COPIES.

WGI, INC.  
800 N. MAGNOLIA AVE., SUITE 1750  
ORLANDO, FL 32803  
CERTIFICATE OF AUTHORIZATION NO. 6091  
HENRI V. BELROSE, P.E. NO. 56761

THE ABOVE NAMED PROFESSIONAL ENGINEER SHALL BE RESPONSIBLE FOR THE FOLLOWING SHEETS IN ACCORDANCE WITH RULE 61G15-23.004, F.A.C.

TYPICAL SECTION PACKAGE

SHEET NO	SHEET DESCRIPTION
1	COVER SHEET
2	TYPICAL SECTION NO. 1
3	TYPICAL SECTION NO. 2
4	TYPICAL SECTION NO. 3
5	TYPICAL SECTION NO. 4
6	TYPICAL SECTION NO. 5

SHEET NO.

1

**PROJECT CONTROLS**

**CONTEXT CLASSIFICATION**

- ( ) C1 : NATURAL                      ( ) C3C : SUBURBAN COMM.
- ( ) C2 : RURAL                        (X) C4 : URBAN GENERAL
- ( ) C2T : RURAL TOWN                ( ) C5 : URBAN CENTER
- ( ) C3R : SUBURBAN RES.            ( ) C6 : URBAN CORE
- ( ) N/A : L.A. FACILITY

**FUNCTIONAL CLASSIFICATION**

- ( ) INTERSTATE                        ( ) MAJOR COLLECTOR
- ( ) FREEWAY/EXPWY.                ( ) MINOR COLLECTOR
- ( ) PRINCIPAL ARTERIAL            ( ) LOCAL
- (X) MINOR ARTERIAL

**HIGHWAY SYSTEM**

- ( ) NATIONAL HIGHWAY SYSTEM
- ( ) STRATEGIC INTERMODAL SYSTEM
- (X) STATE HIGHWAY SYSTEM
- ( ) OFF-STATE HIGHWAY SYSTEM

**ACCESS CLASSIFICATION**

- ( ) 1 - FREEWAY
- ( ) 2 - RESTRICTIVE w/Service Roads
- ( ) 3 - RESTRICTIVE w/660 ft. Connection Spacing
- (X) 4 - NON-RESTRICTIVE w/2640 ft. Signal Spacing
- ( ) 5 - RESTRICTIVE w/440 ft. Connection Spacing
- ( ) 6 - NON-RESTRICTIVE w/1320 ft. Signal Spacing
- ( ) 7 - BOTH MEDIAN TYPES

**CRITERIA**

- (X) NEW CONSTRUCTION / RECONSTRUCTION
- ( ) RESURFACING (LA FACILITIES)
- ( ) RRR (ARTERIALS & COLLECTORS)

**POTENTIAL EXCEPTIONS AND VARIATIONS RELATED TO TYPICAL SECTION:**

SHARED USE PATH WIDTH

**TYPICAL SECTION No. 1**

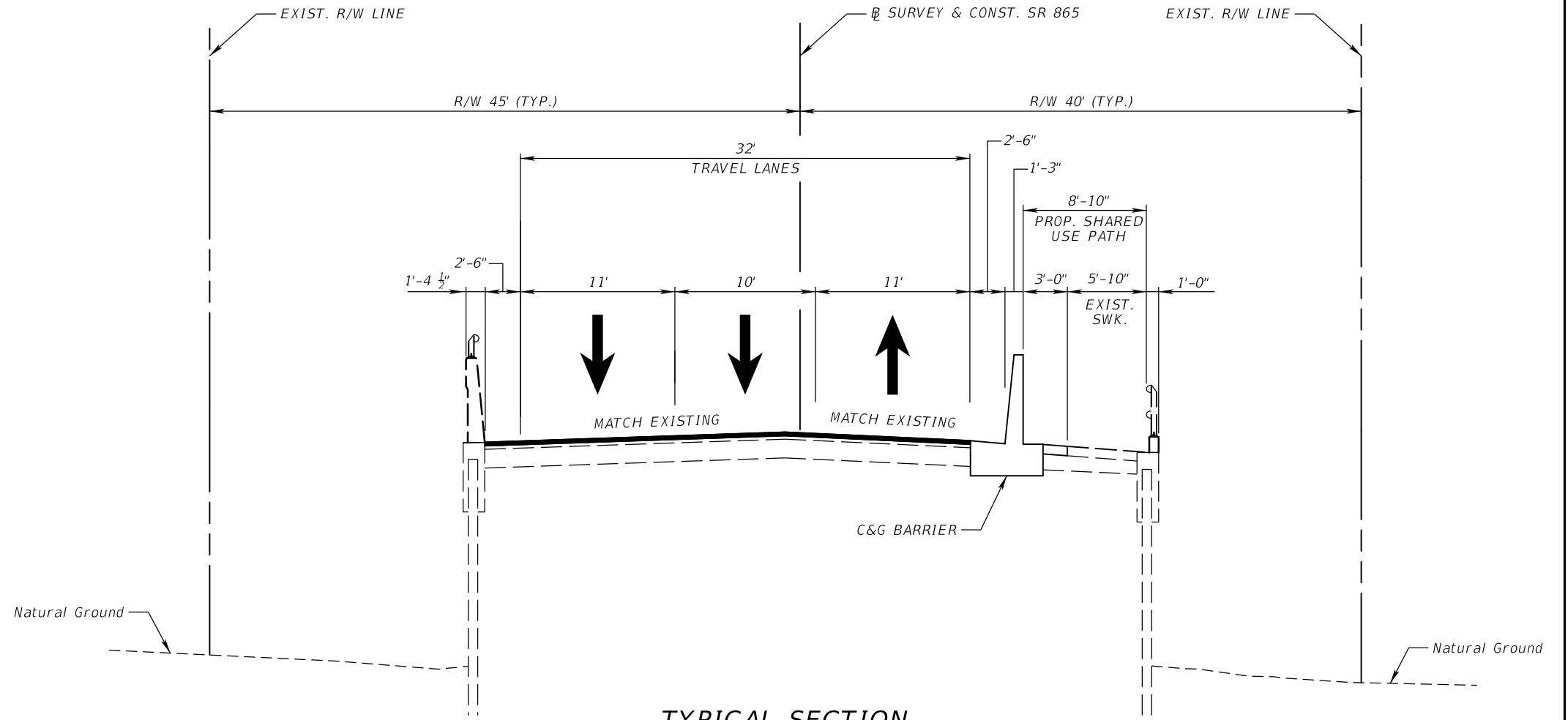

**TYPICAL SECTION  
SR 865  
STA. 15+48.82 TO STA. 19+50.40**

**TRAFFIC DATA**

CURRENT YEAR = 2015 AADT = 21500  
 ESTIMATED OPENING YEAR = 2020 AADT = 22100  
 ESTIMATED DESIGN YEAR = 2040 AADT = 24600  
 K = 9% D = 55% T = 3% (24 HOUR)  
 DESIGN HOUR T = 3%  
 TARGET SPEED = 35 MPH  
 DESIGN SPEED = 35 MPH  
 POSTED SPEED = 35 MPH

FINANCIAL PROJECT ID	SHEET NO.
433726-2-32-01	2

THE OFFICIAL RECORD OF THIS SHEET IS THE ELECTRONIC FILE DIGITALLY SIGNED AND SEALED UNDER RULE 61G15-23.004, F.A.C.



**PROJECT CONTROLS**

**CONTEXT CLASSIFICATION**

- ( ) C1 : NATURAL                      ( ) C3C : SUBURBAN COMM.
- ( ) C2 : RURAL                        (X) C4 : URBAN GENERAL
- ( ) C2T : RURAL TOWN                ( ) C5 : URBAN CENTER
- ( ) C3R : SUBURBAN RES.            ( ) C6 : URBAN CORE
- ( ) N/A : L.A. FACILITY

**FUNCTIONAL CLASSIFICATION**

- ( ) INTERSTATE                        ( ) MAJOR COLLECTOR
- ( ) FREEWAY/EXPWY.                ( ) MINOR COLLECTOR
- ( ) PRINCIPAL ARTERIAL              ( ) LOCAL
- (X) MINOR ARTERIAL

**HIGHWAY SYSTEM**

- ( ) NATIONAL HIGHWAY SYSTEM
- ( ) STRATEGIC INTERMODAL SYSTEM
- (X) STATE HIGHWAY SYSTEM
- ( ) OFF-STATE HIGHWAY SYSTEM

**ACCESS CLASSIFICATION**

- ( ) 1 - FREEWAY
- ( ) 2 - RESTRICTIVE w/Service Roads
- ( ) 3 - RESTRICTIVE w/660 ft. Connection Spacing
- (X) 4 - NON-RESTRICTIVE w/2640 ft. Signal Spacing
- ( ) 5 - RESTRICTIVE w/440 ft. Connection Spacing
- ( ) 6 - NON-RESTRICTIVE w/1320 ft. Signal Spacing
- ( ) 7 - BOTH MEDIAN TYPES

**CRITERIA**

- (X) NEW CONSTRUCTION / RECONSTRUCTION
- ( ) RESURFACING (LA FACILITIES)
- ( ) RRR (ARTERIALS & COLLECTORS)

**POTENTIAL EXCEPTIONS AND VARIATIONS RELATED TO TYPICAL SECTION:**

SHARED USE PATH WIDTH  
SHOULDER WIDTH

**TYPICAL SECTION No. 2**

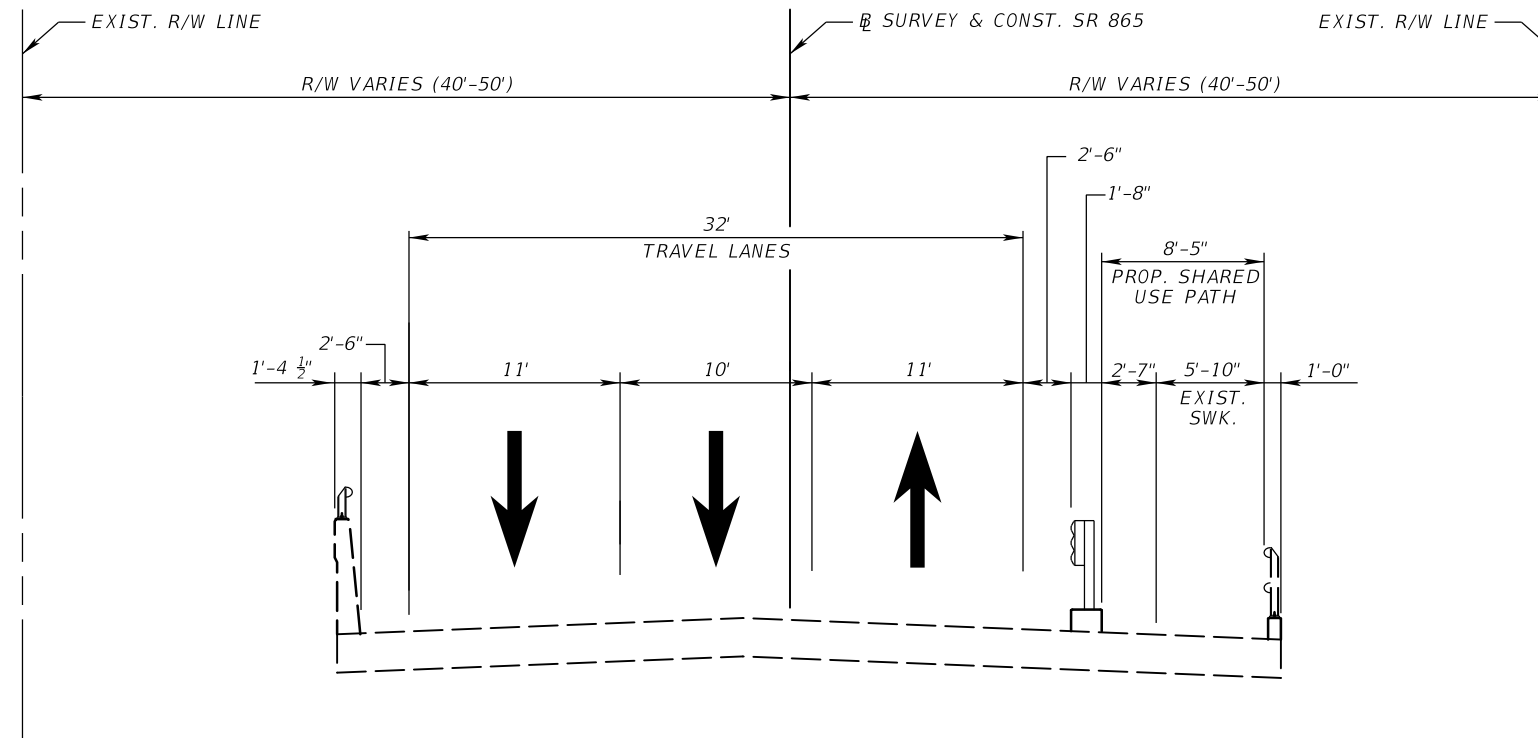

**TYPICAL SECTION  
SR 865 OVER MATANZAS PASS (BR. #120088)  
STA. 19+50.40 TO STA. 40+53.01**

**TRAFFIC DATA**

CURRENT YEAR = 2015 AADT = 21500  
ESTIMATED OPENING YEAR = 2020 AADT = 22100  
ESTIMATED DESIGN YEAR = 2040 AADT = 24600  
K = 9% D = 55% T = 3% (24 HOUR)  
DESIGN HOUR T = 3%  
TARGET SPEED = 35 MPH  
DESIGN SPEED = 35 MPH  
POSTED SPEED = 35 MPH

FINANCIAL PROJECT ID	SHEET NO.
433726-2-32-01	3

THE OFFICIAL RECORD OF THIS SHEET IS THE ELECTRONIC FILE DIGITALLY SIGNED AND SEALED UNDER RULE 61G15-23.004, F.A.C.

**PROJECT CONTROLS**

**CONTEXT CLASSIFICATION**

- ( ) C1 : NATURAL                      ( ) C3C : SUBURBAN COMM.
- ( ) C2 : RURAL                        (X) C4 : URBAN GENERAL
- ( ) C2T : RURAL TOWN                ( ) C5 : URBAN CENTER
- ( ) C3R : SUBURBAN RES.            ( ) C6 : URBAN CORE
- ( ) N/A : L.A. FACILITY

**FUNCTIONAL CLASSIFICATION**

- ( ) INTERSTATE                        ( ) MAJOR COLLECTOR
- ( ) FREEWAY/EXPWY.                ( ) MINOR COLLECTOR
- ( ) PRINCIPAL ARTERIAL            ( ) LOCAL
- (X) MINOR ARTERIAL

**HIGHWAY SYSTEM**

- ( ) NATIONAL HIGHWAY SYSTEM
- ( ) STRATEGIC INTERMODAL SYSTEM
- (X) STATE HIGHWAY SYSTEM
- ( ) OFF-STATE HIGHWAY SYSTEM

**ACCESS CLASSIFICATION**

- ( ) 1 - FREEWAY
- ( ) 2 - RESTRICTIVE w/Service Roads
- ( ) 3 - RESTRICTIVE w/660 ft. Connection Spacing
- (X) 4 - NON-RESTRICTIVE w/2640 ft. Signal Spacing
- ( ) 5 - RESTRICTIVE w/440 ft. Connection Spacing
- ( ) 6 - NON-RESTRICTIVE w/1320 ft. Signal Spacing
- ( ) 7 - BOTH MEDIAN TYPES

**CRITERIA**

- (X) NEW CONSTRUCTION / RECONSTRUCTION
- ( ) RESURFACING (LA FACILITIES)
- ( ) RRR (ARTERIALS & COLLECTORS)

**POTENTIAL EXCEPTIONS AND VARIATIONS RELATED TO TYPICAL SECTION:**

**TYPICAL SECTION No. 3**

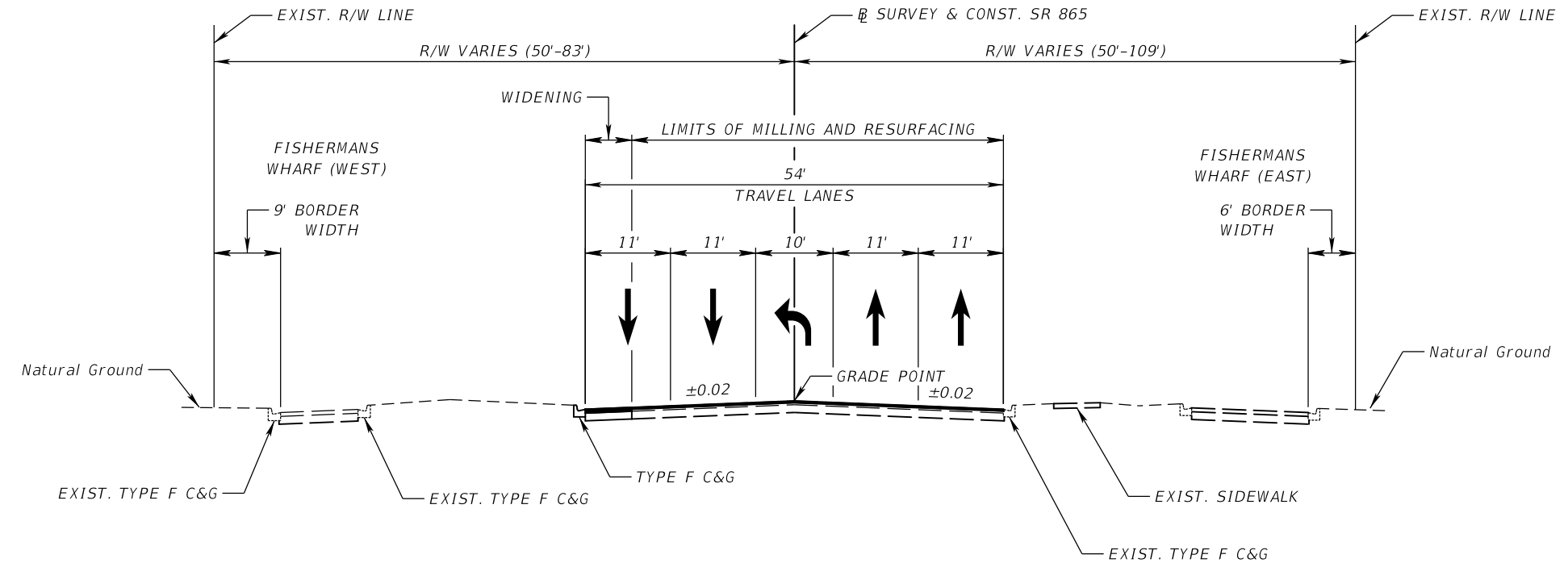

**TYPICAL SECTION  
SR 865  
STA. 40+53.01 TO STA. 46+22.64**

**TRAFFIC DATA**

CURRENT YEAR = 2015 AADT = 21500  
 ESTIMATED OPENING YEAR = 2020 AADT = 22100  
 ESTIMATED DESIGN YEAR = 2040 AADT = 24600  
 K = 9% D = 55% T = 4% (24 HOUR)  
 DESIGN HOUR T = 4%  
 TARGET SPEED = 35 MPH  
 DESIGN SPEED = 35 MPH  
 POSTED SPEED = 35 MPH

FINANCIAL PROJECT ID	SHEET NO.
433726-2-32-01	4

THE OFFICIAL RECORD OF THIS SHEET IS THE ELECTRONIC FILE DIGITALLY SIGNED AND SEALED UNDER RULE 61G15-23.004, F.A.C.

**PROJECT CONTROLS**

**CONTEXT CLASSIFICATION**

- ( ) C1 : NATURAL            (X) C3C : SUBURBAN COMM.
- ( ) C2 : RURAL             ( ) C4 : URBAN GENERAL
- ( ) C2T : RURAL TOWN    ( ) C5 : URBAN CENTER
- ( ) C3R : SUBURBAN RES. ( ) C6 : URBAN CORE
- ( ) N/A : L.A. FACILITY

**FUNCTIONAL CLASSIFICATION**

- ( ) INTERSTATE            ( ) MAJOR COLLECTOR
- ( ) FREEWAY/EXPWY.    ( ) MINOR COLLECTOR
- ( ) PRINCIPAL ARTERIAL ( ) LOCAL
- (X) MINOR ARTERIAL

**HIGHWAY SYSTEM**

- ( ) NATIONAL HIGHWAY SYSTEM
- ( ) STRATEGIC INTERMODAL SYSTEM
- (X) STATE HIGHWAY SYSTEM
- ( ) OFF-STATE HIGHWAY SYSTEM

**ACCESS CLASSIFICATION**

- ( ) 1 - FREEWAY
- ( ) 2 - RESTRICTIVE w/Service Roads
- ( ) 3 - RESTRICTIVE w/660 ft. Connection Spacing
- ( ) 4 - NON-RESTRICTIVE w/2640 ft. Signal Spacing
- ( ) 5 - RESTRICTIVE w/440 ft. Connection Spacing
- ( ) 6 - NON-RESTRICTIVE w/1320 ft. Signal Spacing
- (X) 7 - BOTH MEDIAN TYPES

**CRITERIA**

- (X) NEW CONSTRUCTION / RECONSTRUCTION
- ( ) RESURFACING (LA FACILITIES)
- ( ) RRR (ARTERIALS & COLLECTORS)

**POTENTIAL EXCEPTIONS AND VARIATIONS RELATED TO TYPICAL SECTION:**

BICYCLE LANE WIDTH

**TYPICAL SECTION No. 4**

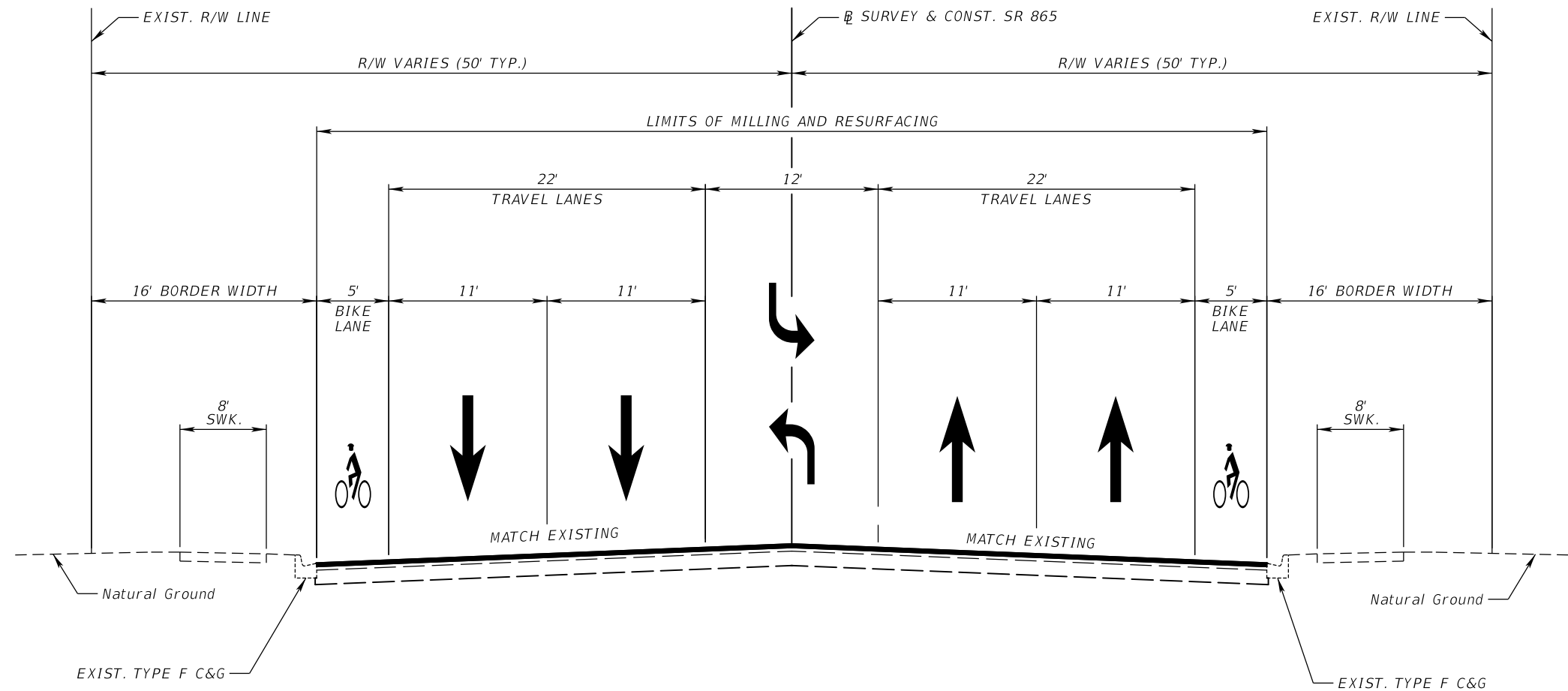

**TYPICAL SECTION  
SR 865  
STA. 105+00.72 TO STA. 121+01.91  
STA. 124+52.20 TO STA. 129+00.08**

**TRAFFIC DATA**

CURRENT YEAR = 2015 AADT = 22700  
 ESTIMATED OPENING YEAR = 2020 AADT = 23400  
 ESTIMATED DESIGN YEAR = 2040 AADT = 26400  
 K = 9% D = 55% T = 3% (24 HOUR)  
 DESIGN HOUR T = 3%  
 TARGET SPEED = 40 MPH  
 DESIGN SPEED = 40 MPH  
 POSTED SPEED = 40 MPH

FINANCIAL PROJECT ID	SHEET NO.
433726-2-32-01	5

THE OFFICIAL RECORD OF THIS SHEET IS THE ELECTRONIC FILE DIGITALLY SIGNED AND SEALED UNDER RULE 61G15-23.004, F.A.C.

**PROJECT CONTROLS**

**CONTEXT CLASSIFICATION**

- ( ) C1 : NATURAL                      (X) C3C : SUBURBAN COMM.
- ( ) C2 : RURAL                        ( ) C4 : URBAN GENERAL
- ( ) C2T : RURAL TOWN                ( ) C5 : URBAN CENTER
- ( ) C3R : SUBURBAN RES.            ( ) C6 : URBAN CORE
- ( ) N/A : L.A. FACILITY

**FUNCTIONAL CLASSIFICATION**

- ( ) INTERSTATE                        ( ) MAJOR COLLECTOR
- ( ) FREEWAY/EXPWY.                ( ) MINOR COLLECTOR
- ( ) PRINCIPAL ARTERIAL              ( ) LOCAL
- (X) MINOR ARTERIAL

**HIGHWAY SYSTEM**

- ( ) NATIONAL HIGHWAY SYSTEM
- ( ) STRATEGIC INTERMODAL SYSTEM
- (X) STATE HIGHWAY SYSTEM
- ( ) OFF-STATE HIGHWAY SYSTEM

**ACCESS CLASSIFICATION**

- ( ) 1 - FREEWAY
- ( ) 2 - RESTRICTIVE w/Service Roads
- ( ) 3 - RESTRICTIVE w/660 ft. Connection Spacing
- ( ) 4 - NON-RESTRICTIVE w/2640 ft. Signal Spacing
- ( ) 5 - RESTRICTIVE w/440 ft. Connection Spacing
- ( ) 6 - NON-RESTRICTIVE w/1320 ft. Signal Spacing
- (X) 7 - BOTH MEDIAN TYPES

**CRITERIA**

- (X) NEW CONSTRUCTION / RECONSTRUCTION
- ( ) RESURFACING (LA FACILITIES)
- ( ) RRR (ARTERIALS & COLLECTORS)

**POTENTIAL EXCEPTIONS AND VARIATIONS RELATED TO TYPICAL SECTION:**

- BICYCLE LANE WIDTH
- SIDEWALK WIDTH
- AUXILIARY LANE WIDTH

**TYPICAL SECTION No. 5**

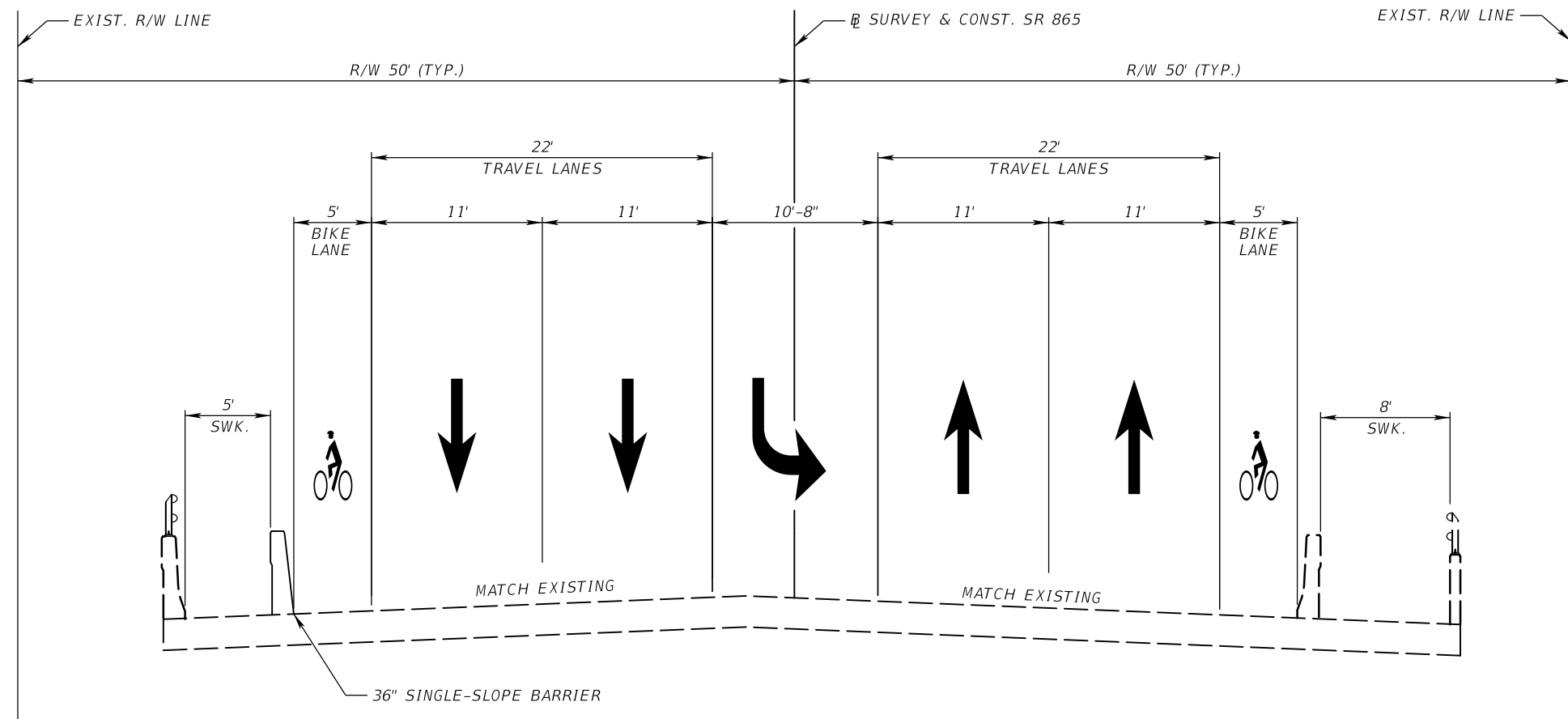

**TYPICAL SECTION  
SR 865 OVER HURRICANE BAY (BR. #120089)  
STA. 121+01.91 TO STA. 124+52.20**

**TRAFFIC DATA**

CURRENT YEAR = 2015 AADT = 25100  
 ESTIMATED OPENING YEAR = 2020 AADT = 25900  
 ESTIMATED DESIGN YEAR = 2040 AADT = 29000  
 K = 9% D = 55% T = 4% (24 HOUR)  
 DESIGN HOUR T = 3%  
 TARGET SPEED = 40 MPH  
 DESIGN SPEED = 40 MPH  
 POSTED SPEED = 40 MPH

FINANCIAL PROJECT ID	SHEET NO.
433726-2-32-01	6

THE OFFICIAL RECORD OF THIS SHEET IS THE ELECTRONIC FILE DIGITALLY SIGNED AND SEALED UNDER RULE 61G15-23.004, F.A.C.