

TECHNICAL REPORT COVERSHEET

LOCATION HYDRAULICS REPORT

Florida Department of Transportation

District One

Old Dixie Trail Project Development and Environment Study

Limits of Project: From TECO-Auburndale Trailhead to Haines City Trailhead

Polk County, Florida

Financial Management Number: 435391-1-22-01

ETDM Number: 14328

Date: September 2024

The environmental review, consultation, and other actions required by applicable federal environmental laws for this project are being, or have been, carried out by the Florida Department of Transportation (FDOT) pursuant to 23 U.S.C. § 327 and a Memorandum of Understanding dated May 26, 2022, and executed by the Federal Highway Administration and FDOT.

DRAFT

PROFESSIONAL ENGINEER CERTIFICATION

I hereby certify that I am a registered professional engineer in the State of Florida practicing with the HNTB Corporation. I have reviewed or approved the evaluation, findings, opinions and conclusions as reported for:

Project: Old Dixie Trail Project Development and Environment Study
Auburndale Trailhead of the Auburndale TECO Trail to the Haines City Trailhead of the Haines City Trail, Polk County, Florida

FPID Number: 435391-1-22-01

The engineering work represented by this document was performed through the following duly authorized engineering business:

HNTB Corporation
201 N. Franklin Street, Suite 1200
Tampa, Florida 33602

This report provides the results of the analysis required for the floodplain encroachments for the Old Dixie Trail project in Polk County. I acknowledge that the procedures and references used to develop the results contained in this report are standard to the professional practice of civil engineering as applied through design standards and criteria set forth by the federal, state, and local regulatory agencies as well as professional judgment and experience.

Any engineering analysis, documents, conclusions, or recommendations relied upon from other professional sources or provided with responsibility by the client are referenced accordingly in the report.

Signature: _____
Name: Hong Ting Chiu, P.E.
P.E. Number: 80386
Date: _____



Table of Contents

EXECUTIVE SUMMARY	v
1 PROJECT OVERVIEW	1
2 DATA COLLECTION.....	6
2.1 Technical References	6
2.2 Data	6
2.3 Field Review.....	6
3 EXISTING DRAINAGE CONDITIONS.....	7
3.1 Drainage Basins	7
3.2 Environmental Characteristics.....	10
3.3 Land Use	10
3.4 Soil Types	10
3.5 Floodplains.....	11
3.6 Permits	11
3.7 Project Datum.....	13
4 PROPOSED DRAINAGE CONDITIONS	14
4.1 Drainage Basins.....	14
4.2 Floodplain Impact and Level of Encroachment.....	15
4.3 Permitting.....	17
4.4 Risk Evaluation	17
4.5 Minimal Encroachment.....	17
5 CONCLUSION.....	20

List of Figures

Figure 1-1 Project Location Map.....	1
--------------------------------------	---



List of Tables

Table 3-1 Summary of Existing Cross Drains	8
Table 3-2 Summary of Waterbodies	10
Table 3-3 Summary of Existing Approved Permits.....	12
Table 4-1 Impacted Cross Drains	15
Table 4-2 Summary of Floodplain Impacts	16

List of Appendices

APPENDIX A: Exhibits
APPENDIX B: FEMA FIRM
APPENDIX C: Field Review Memo
APPENDIX D: HY-8 Models
APPENDIX E: USDA NRCS
APPENDIX F: Correspondence



EXECUTIVE SUMMARY

The Florida Department of Transportation (FDOT) District One is conducting a Project Development and Environment (PD&E) Study, in accordance with the National Environmental Policy Act (NEPA) to provide regional connectivity, contribute to safe multimodal access to community and recreational destinations, enhance quality of life and foster economic development in the area for the Old Dixie Trail. The project proposes a varying 10 to 12-foot trail with five foot buffers on both sides of the trail and approximately 13 miles in length, between the Auburndale Trailhead of the Auburndale TECO Trail to the Haines City Trailhead of the Haines City Trail in Polk County.

In the existing drainage condition, the project is located within eight Florida Department of Environmental Protection (FDEP) waterbodies. The proposed trail will cross 25 existing cross drains. Land use along the project includes agricultural, commercial, residential and wetland. There are 36 different soil types within the project limits. The proposed trail is located within Flood Zone A, AE and X and one designed floodway near Haines City.

In the proposed drainage conditions, the drainage basins are intended to remain the same as existing. Eight cross drains are anticipated to require extension or replacement. This project will impact the 100-year floodplain both transversely and longitudinally. Transverse floodplain encroachments will result from filling floodplain areas due to extension or replacement of existing cross drains. Longitudinal floodplain encroachments will be due to filling the floodplain areas running parallel to the proposed trail. As a result, preliminary design calculations estimated 0.72 acre-feet of potential floodplain encroachment. Therefore, the proposed trail is expected to have minimal encroachments on the floodplain. During final design, every effort should be taken to minimize floodplain impacts.

Modification to existing drainage structures (extending cross drains) that will result in an insignificant change in their capacity to carry floodwater. These modifications will cause minimal increases in flood heights and flood limits which will not result in any significant adverse impacts on the natural and beneficial floodplain values or any significant change in flood risks or damage. There will be no significant change in the potential for interruption or termination of emergency service or emergency evacuation routes as the result of modifications to existing drainage structures.

The proposed structure will perform hydraulically in a manner equal to or greater than the existing structure, and backwater surface elevations are not expected to increase. Thus, there will be no significant adverse impacts on natural and beneficial floodplain values. There will be no significant change in flood risk, and there will not be a significant change in the potential for interruption or termination of emergency service or emergency evacuation routes.

Therefore, it has been determined that this encroachment is not significant.



1 PROJECT OVERVIEW

The Florida Department of Transportation (FDOT) District One is conducting a Project Development and Environment (PD&E) Study, in accordance with National Environmental Policy Act (NEPA) to provide regional connectivity, contribute to safe multimodal access to community and recreational destinations, enhance quality of life and foster economic development in the area for the Old Dixie Trail. The project proposes a varying 10- to 12-foot-wide multi-use trail with five foot buffers on both sides of the trail and approximately 13 miles in length, between the Auburndale Trailhead of the Auburndale Tampa Electric Company (TECO) Trail to the Haines City Trailhead of the Haines City Trail in Polk County. A project location map has been included as **Figure 1-1**.

This project will require 7.5 acres of additional right-of-way (ROW) to accommodate the multi-use trail and no stormwater management systems and floodplain compensation sites are proposed.

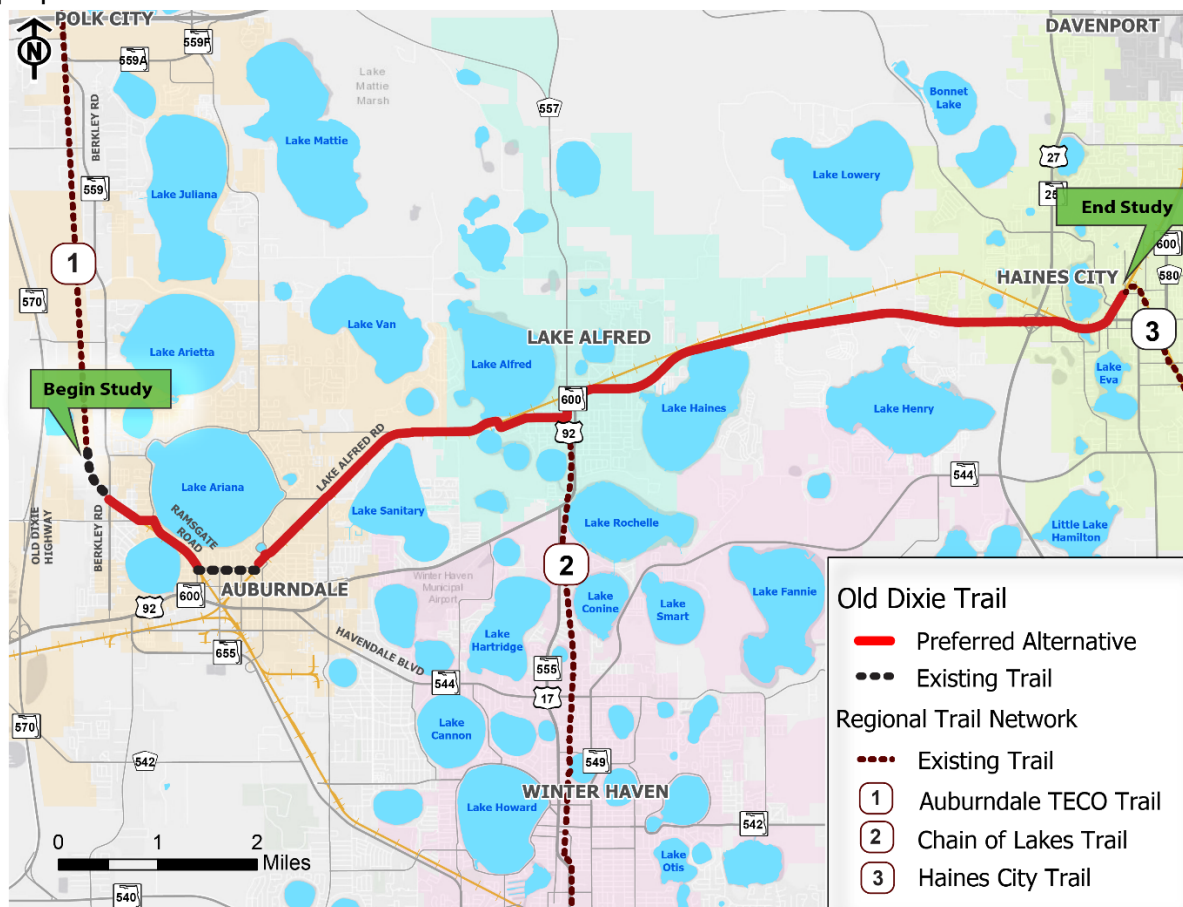

Figure 1-1 Project Location Map



1.1 Purpose and Need

The purpose of the project is to address an existing gap in the regional trail network between the communities of Auburndale and Haines City in Polk County, Florida. Other goals of the project are to 1) provide a safe, viable, nonmotorized travel option for commuters and recreational trail users to access area destinations and 2) support quality of life and economic objectives of the surrounding area. The need for the proposed trail project is based on the following:

Area Wide Network / System Linkage: Regional Bicycle and Pedestrian Connectivity

As identified by the Florida Department of Environmental Protection Office of Greenways and Trails, Old Dixie Trail is proposed to serve as part of the regional Heartland Trail and, in turn, part of Florida's designated Shared-Use Nonmotorized (SUN) trail network. The proposed project also aligns with the stated goal of Polk County to create a connected multimodal transportation system. As the project is expected to link to existing trails of the area [including the Haines City Trail, Chain of Lakes / Lake Alfred Trail, and Auburndale Trail / Van Fleet Trail] it is intended to bridge a gap in the regional trail system as well as address the need for a connected bicycle and pedestrian network, especially within Polk County.

Safety: Provide Safe Multimodal Access to Destinations

Old Dixie Trail is proposed to link the communities of Auburndale and Haines City to each other [including each community's respective amenities] through trailheads, as well as connect the two communities to the region's schools, parks, cultural resources, employment centers, recreational facilities, conservation viewsheds, and other area destinations. Pedestrian and bicycle traffic has been observed in the field given the presence of these community and regional focal points despite the presence of intermittent and disconnected sidewalks and bicycle lanes.

Overall, Old Dixie Trail is expected to:

- Provide a facility separated from area roadways to minimize conflicts between non-motorized travel modes and vehicles, creating safer travel conditions for both trail users and vehicular traffic on area roadways;
- Provide a safe, viable, non-motorized travel option for commuters and recreational trail users to access area destinations supporting both economic productivity and enhanced quality of life aspects; and
- Address the latent demand for increased bicycle and pedestrian activity due to improved access to the present community and regional focal points.



Social and Economic Demand: Enhance Quality of Life and Foster Economic Development

The project occurs within two of the eight Polk County planning areas [Central Planning Area and East Planning Area] as depicted in Momentum 2040. Of the eight planning areas, the East Planning Area is expected to experience the highest increase in population growth between 2010 and 2040 with a 29% increase in single family dwelling units and a 34% increase in multi-family dwelling units. The Central Planning Area is anticipated to experience the second highest increase in single family dwelling units (25% increase) during the same time period. Accordingly, the Central Planning Area will experience the highest increase in employment growth between 2010 and 2040 with a 42% increase in industrial employment, 34% increase in commercial employment, and a 32% increase in service employment. Likewise, the East Planning Area will experience the second highest increase in commercial employment (26% increase) and the third highest increase in service employment (21% increase) during the same time period.

Given the projected area growth and the large presence of residential areas, employment centers, schools, recreational facilities, and other destinations in the area, the need for improved travel options and multimodal access to the noted focal points is more critical. The proposed trail is intended to incentivize new businesses to the area by providing linkages to population and employment concentrations and area destinations. The proposed trail supports economic productivity for area businesses and enhances the quality-of-life aspects for Polk County residents.

1.1.1 Study Area/Action Area

The study area for the proposed project includes connecting the Auburndale TECO trailhead in Auburndale to the Haines City trailhead in Haines City. The study area consists of numerous transportation options including roadways, transit, and multi-use trails that span four municipalities, Auburndale, Winter Haven, Lake Alfred, and Haines City. The proposed project will connect to existing multi-use trails as well as provide regional connectivity.

The project was screened through the FDOT Efficient Transportation Decision Making (ETDM) process and given ETDM number 14328. An ETDM *Programming Screen Summary Report*, published on October 15, 2019, contains comments from the Environmental Technical Advisory Team (ETAT) on the project's effects on various natural, physical and social resources.



1.2 Alternatives

1.2.1 Build

Two build alternatives were analyzed for the Old Dixie Trail PD&E Study and are described in more detail in the Preliminary Engineering Report (PER).

The Preferred Alternative (hereafter referred to as 'Project') is an approximately 13-mile multi-use trail that begins in Auburndale and traverses along Lake Alfred Road and US 17/92 and terminates in Haines City. The Project, which is a varying 10 to 12-foot trail with five foot buffers on both sides of the trail, captures the limits of construction activities. The Project connects the cities of Auburndale, Lake Alfred, and Haines City. This Project will service several destinations, including the historic area of downtown Auburndale and the commercial areas of Lake Alfred and Haines City. The Project offers both scenic and rural vistas along portions of Lake Alfred Road and US 17/92. The Project is located adjacent to existing recreational facilities, including Downtown City Park in Auburndale and the existing Chain of Lakes trail located along US 17. The Project will typically traverse along the northside of the road from the begin project to about Shinn Boulevard and E. Pomelo Street (in the vicinity of US 17/92) where the multi-use trail will be located along the southside of US 17/92 to Haines City. To accommodate the varying 10- to 12-foot-wide trail, ROW will be required at several locations.

1.2.2 No-Build

The No-Build alternative assumes that the existing conditions would remain within the project limits. No proposed right-of-way would be needed for the No-Build alternative. However, the No-Build alternative would not provide the support for the identified economic opportunities that the Old Dixie Trail would support. Also, the No-Build alternative would not connect the Auburndale TECO and Haines City Trail micromobility transportation networks causing non-motorized users to find less than ideal routes between Auburndale and Haines City.

1.2.3 Typical Sections

Ten typical sections have been developed for the 10 segments of Old Dixie Trail. These typical sections depict the 10-12' multi-use trail connecting the Auburn TECO Trail with the Haines City trail at their respective trailheads. Typical sections are shown in the PER.

1.2.3.1 Typical Section Criteria

The FDOT Context Classification Guide, July 2020 classifies this project as C2 Rural and C2T Rural Town context classification as this project passes through and connects the rural towns of Auburndale, Lake Alfred, and Haines City along major rural collectors and arterials. Initial typical sections were developed based on the FDOT Design Manual, 2023 criteria and feedback from FDOT, Polk County, and Haines City. Subsequent meetings with Haines City led to further discussions concerning trail location and minimum width requirements for the trail within Haines City.



1.2.3.2 Study Typical Sections

The proposed typical sections were initially analyzed for this PD&E study with refinements to incorporate changes to the roadway buffer width requirements within the FDOT Design Manual (FDM), along with developing alternative sections to present to FDOT and Haines City for the 6th Street and Court Avenue corridors.

The typical sections used for this PD&E study can be found in the PER.

1.2.3.3 Recommended Typical Sections

The recommended typical sections were developed from the proposed typical sections and from discussions with FDOT and Haines City to incorporate their preferred alternative for the 6th Street corridor. The recommended typical sections developed during this study can be found in the PER.



2 DATA COLLECTION

2.1 Technical References

- FDOT Drainage Manual (January 2024)
- FDOT Drainage Design Guide (January 2024)
- Southwest Florida Water Management District (SWFWMD) Environmental Resource Permit (ERP) Applicant's Handbook Volume II (June 2018)

2.2 Data

- Light Detection and Ranging (LiDAR)
- Federal Emergency Management Agency (FEMA) Flood Insurance Rate Maps (FIRM) (December 2016)
- United States Department of Agriculture (USDA) Natural Resources Conservation Service (NRCS) Soil Map
- Florida Department of Environmental Protection (FDEP) Statewide Comprehensive Verified List of Impaired Waters (July 2022)
- Polk County Parcels
- SWFWMD ERP Permits
- FDOT/SWFWMD As-built Plans
- FDOT Straight Line Diagrams (SLD)
- SWFWMD Peace Creek Watershed Model (2016)
- SWFWMD Lake Hancock Watershed Model (2013)
- SWFWMD Haines City Watershed Model (2021)

2.3 Field Review

- Field Review (August 2019)



3 EXISTING DRAINAGE CONDITIONS

3.1 Drainage Basins

The project falls within eight FDEP waterbodies: Lake Haines (waterbody identification number (WBID) 1488C), Lake Hamilton Canal (WBID 1500A), Lake Lena Run (WBID 1501A), Lake Ariana Drain (WBID 1501F), Lake Van Outlet (WBID 1503A), Lake Hamilton Outlet (WBID 1504), Lake Hamilton Drain (WBID 1504B), and Lake Lulu Outlet (WBID 1521C1). The drainage basin map is in **Appendix A**.

At the beginning of the project, the proposed design is within an abandon rail line. Runoff from the abandon rail line sheet flows into an open channel conveyance system that ultimately discharges to Lake Lena. Along Old Lakeland Auburndale Road, there is no apparent drainage conveyance as runoff appears to sheet flow into a strip of sod between the sidewalk and road. Along Ramsgate Road, runoff sheet flows into an open channel conveyance system and ultimately discharges to Lake Lena. As Ramsgate Road begins to transition into an urban section in the City of Auburndale, runoff is channelized by a curb and will connect to an existing trail.

The proposed trail resumes at Downtown City Park in the City of Auburndale and travels east. Along W Park Street, runoff flows along the curb and is collected in a closed storm drain system. Along Stadium Road, runoff is collected in an open channel conveyance system, outfalling to an offsite wetland and ultimately to Lake Ariana. Lake Alfred Road and W Pierce Street do not have a defined drainage conveyance system and sheet flows offsite ultimately discharging into the surround lakes. The proposed trail connects to an existing trail within the City of Lake Alfred.

In the City of Lake Alfred, the proposed trail restarts at the southwest intersection of W Haines Boulevard and Shinn Boulevard (US 17/US 92). Along US 17, until N Ramona Avenue, runoff is collected in closed storm drain system. East of N Ramona Avenue and to east of US 27, runoff sheet flows offsite or is collected into open channel conveyance system, ultimately discharging into the surrounding lakes. East of US 27, runoff is collected into closed storm drain system.

There are 25 cross drains within the project limits. Cross drain (CD) locations can be seen in **Appendix A**. An inventory of the existing cross drains is summarized in **Table 3-1**. If cross drains were not accessible in the field, cross drain information from watershed models, SLDs or as-builts were utilized. The Field Review Memo can be found in **Appendix C**.



Table 3-1 Summary of Existing Cross Drains

Cross Drain	Location	Description
CD 01	Berkley Road and Deen Blvd.	(1) 24" Pipe
CD 02	Proposed Trail and Herrick Street	(1) 15" Pipe
CD 03	Proposed Trail and James Street	(1) 30" Pipe
CD 04	Proposed Trail and west side of Clayton Rd.	(1) 30" Pipe
CD 05	Proposed Trail and east side of Clayton Rd.	(2) 30" Pipes
CD 06	Dixie Highway and east side of Lakedale Dr.	(1) 30" Pipe
CD 07	Ramsgate Road approx. 600-ft south of Lake Ariana Blvd	(1) 18" Pipe
CD 08	Ramsgate Road approx. 350-ft northwest of Ralford Road	(1) 10.2' x 8.5' Concrete Box Culvert
CD 09	Crossing Stadium Road approx. 235-ft west of Bennett Street	(1) 24" Pipe
CD 10	Along Stadium Road approx. 450-ft northeast of Bennett Street	(1) 15" Pipe
CD 11	Along Stadium Road approx. 670-ft northeast of Bennett Street	(1) 18" Pipe
CD 12	Stadium Road approx. 1700-ft southwest of the intersection of Lake Alfred Dr. and Dairy Rd.	(1) 24" Pipe



Table 3-1 Summary of Existing Cross Drains (Continued)

Cross Drain	Location	Description
CD 13	Old Lake Alfred Road approx. 400-ft west of W Pierce Street	(1) 4' x 3' Concrete Box Culvert
CD 14	US 17/US 92 approx. 600-ft east of N Ramona Ave.	(1) 36" Pipe
CD 15	US 17/US 92 approx. 300-ft west of Mosley Rd.	(1) 36" Pipe
CD 16	US 17/US 92 approx. 2000-ft east of Lee Jackson Road	(1) 6' x 6' Concrete Box Culvert
CD 17	US 17/US 92 approx. 400-ft east of Friendly Ct.	(1) 30" Pipe
CD 18	US 17/US 92 approx. 300-ft west of Century Drive	(4) 36" Pipes
CD 19	US 17/US 92 approx. 1900-ft west of Sweetwater Club Blvd.	(1) 36" Pipe
CD 20	US 17/US 92 approx. 1400-ft east of Sweetwater Club Blvd.	(1) 36" Pipe
CD 21	US 17/US 92 approx. 400-ft west of Royal Palm Blvd.	(1) 48" Pipe
CD 22	US 17/US 92 approx. 200-ft west of Watts Dairy Road	(1) 18" Pipe
CD 23	US 17/US 92 and Moss Street	(1) 30" Pipe
CD 24	US 17/US 92 approx. 250-ft west of US 27	(2) 4' x 4' Concrete Box Culverts
CD 25	US 17/US 92 approx. 250-ft east of US 27	(1) 30" Pipe



3.2 Environmental Characteristics

In separate documents, a Cultural Resource Assessment Survey (CRAS), a Natural Resources Evaluation (NRE) and a Contamination Screening Evaluation Report (CSER) were prepared during this PD&E study. Information regarding historical and archeological impacts from this project can be found in the CRAS. Information regarding wetland and species impacts from this project can be found in the NRE. Information regarding known and/or potential contamination sites near this project can be found in the CSER.

Within the project limits, only Lake Lena Run (WBID 1501A) is impaired. A summary of the verified impaired waterbodies and the Waters Not Attaining Standards (WNAS) list is found in **Table 3-2**.

Table 3-2 Summary of Waterbodies

WBID	WBID Name	Verified List WBID's	WNAS
1488C	Lake Haines	None	Nutrients (Total Phosphorous) Biology Nutrients (Chlorophyll-a) Nutrients (Total Nitrogen)
1500A	Lake Hamilton Canal	None	None
1501A	Lake Lena Run	Escherichia coli	Nutrients (Total Nitrogen) Escherichia coli Nutrients (Chlorophyll-a)
1501F	Lake Ariana Drain	None	None
1503A	Lake Van Outlet	None	None
1504	Lake Hamilton Outlet	None	None
1504B	Lake Hamilton Drain	None	None
1521C1	Lake Lulu Outlet	None	None

3.3 Land Use

Land use along the project includes agricultural, commercial, residential, government and wetland. The proposed trail does not change any land use type. A land use map can be found in **Appendix A**.

3.4 Soil Types

The soil data was obtained from the USDA NRCS Soil Survey for Polk County and reviewed for the project area. The soils encountered along the project limits are mostly Candler Sands, Water, and Candler-Urban land complex. Soils within these limits are from Hydrological Soil Groups (HSG) A, B, C, and D. Most soils found within these limits have low depth to water tables with low infiltration rates when thoroughly wetted as well as high runoff potential. According to the NRCS Soil Report there are thirty-six (36) different types of soil found within



the project limits. The depth to ground water varies along the project limits. The USDA NRCS Soil Survey for Polk County are included in **Appendix E**.

3.5 Floodplains

There are six FEMA FIRM Panel numbers within the project limits: 12105C0330G, 12105C0335G, 12105C0355G, 12105C0356G, 12105C0357G, and 12105C0380G (effective date December 22, 2016) for Polk County. There are both 100-year floodplains (Zone A and Zone AE) and 500-year floodplains (Zone X) within the project limits. The major waterbodies adjacent to the proposed trail are designated Zone AE with established Base Flood Elevations (BFE). These flood zones are typically in low lying areas such as lakes or channels that are subject to inundation during the 100-year storm. Zone A areas do not have an established BFE. There is a designated Floodway surrounding the Haines City Drainage Canal and the existing CD 24 is located at this existing designated Floodway. No adverse impacts are anticipated at this time. FEMA FIRMs can be found in **Appendix B**.

3.6 Permits

There are numerous existing ERPs within the study limits that may be impacted by the proposed project. Existing permit information was gathered from the SWFWMD database, primarily through their online Geographic Information System (GIS) portal. **Table 3-4** identifies the existing approved permits within the study that may be impacted.



Table 3-3 Summary of Existing Approved Permits

Project Name	SWFWMD Permit Number	Permit-Type	Adjacent/ On Corridor
Polk Co CR655 - Old Dixie Hwy to Pace Rd	31455.000	Individual	On Corridor
Berkley Road - Old Dixie Hwy To Pace Rd	31455.002	General	On Corridor
Harvest Time Worship Center	21519.000	General	Adjacent
Banks Lumber Company	15688.000	General	Adjacent
D & D Foods-Proposed Drive Thru	72447	Exemption	Adjacent
Lion Food Store LLC - East Coast Ice House Building	652926	Exemption	Adjacent
PK Avenue / Lake Lena Stormwater Improvement Project	733620	Exemption	On Corridor
Pate, Dwight-Parking	13497.000	General	Adjacent
Auburndale High School- Bus Transfer Parking	7853.007	General	Adjacent
Auburndale High Sch. Auditorium	7029.000	General	Adjacent
Wright Warehouse Addition	18200.000	Minor System	Adjacent
Keystone Hills	44308.001	Individual	Adjacent
Adams Estate	42915.000	Individual	On Corridor
Adams Estate	42915.001	Individual	On Corridor
Adams Estate - Reynolds Hall	42915.002	Individual	On Corridor
Lake Cummings Estates	28682.000	General	On Corridor
Polk Co.-C.R. 555-Lake Alfred	2449.000	General	On Corridor
Lake Alfred Post Office Parking Area Add	19980.000	Minor System	Adjacent
FDOT SR 600 From US 17/92 to Dakota Rd	33080.000	General	On Corridor
FDOT SR 600 From US 17/92 to Dakota Rd	33080.003	Individual	On Corridor
Florida Distillers - Warehouse Expansion	11847.001	General	Adjacent
Lake Alfred-Ramona Ave Drainage Improve	21954.000	General	On Corridor
Standard Lake Alfred, LLC	45646.000	Individual	Adjacent
Austin Shore Restoration	72571	Exemption	Adjacent
RT Plaza - Lake Alfred	32415.000	General	Adjacent
Rt Plaza-Lake Alfred (Rt & Lft Turn Lane)	70946	Exemption	Adjacent
Hidden Golf Club	240.006	General	On Corridor
White Aluminum	29073.000	General	On Corridor
Espisito Project-Us 17-92-New Bldg Add	72393	Exemption	Adjacent
Esposito - Us 17 And 92	30264.000	General	Adjacent
Sweetwater Golf & Tennis-Ph I	2262.000	General	On Corridor
Plantation Landing	1696.000	General	On Corridor



Table 3-2 Summary of Existing Approved Permits (Continued)

Project Name	SWFWMD Permit Number	Permit-Type	Adjacent/ On Corridor
Plantation Landing, Phase I-B	1696.001	General	Adjacent
Plantation Landings, Phase 1-B	1696.002	General	On Corridor
Haines City Lumber Yard-Mod	3599.002	General	Adjacent
Crossroads Village Center	23248.001	Individual	Adjacent
DOT-US 27 Bridge Repl./US 92 #16180-3532	15847.000	General	On Corridor
US 27 Traffic Adaptive Signal Control Technology (Intersection Improvements)	234231.015	General	On Corridor
US 27 Traffic Adaptive Signal Control Technology (Fiber Optics)	234231.016	General	On Corridor
Haines City-Radio Shack Outparcel	73335	Exemption	Adjacent
Haines City Mall Renovation	25161.000	General	Adjacent
Burger King - Haines City	35216.000	Minor System	On Corridor
McDonald's Haines City Rebuild	35416.001	Minor System	On Corridor
Quality Petroleum Corp. - Car Wash # 119	11735.000	General	On Corridor
Sun Bank-Haines City Office	5104.000	General	On Corridor
First Union National Bank-Haines City	16152.000	Minor System	On Corridor
City Of Haines City Streetscape	69679	Exemption	On Corridor
Ember Dog Park	849924	Exemption	Adjacent

3.7 Project Datum

The horizontal datum for this project is the State Plane Coordinate System, Florida West Zone 0902, North American Datum of 1983. The vertical datum for this project is the North American Vertical Datum of 1988 (NAVD 1988). Elevations can be converted from NAVD 1988 to National Geodetic Vertical Datum of 1929 (NGVD 1929) by adding a conversion factor of 0.89 feet.



4 PROPOSED DRAINAGE CONDITIONS

4.1 Drainage Basins

In the proposed conditions, the drainage basins are intended to remain the same as existing. In the location with ditch filling, closed storm drain systems may be needed and will require further evaluation during final design. The drainage basin map and roadway typical section package are in **Appendix A**.

Eight cross drains are anticipated to require extension or replacement. The following assumptions were made:

- No known historical drainage problems.
- Invert elevations were based on the watershed model. If cross drain was not in the model, then invert elevations were based on LiDAR.
- CD 01 and CD 12 are not in an existing watershed model. The discharge rates are estimated based on the existing cross drain diameter per FDOT Drainage Design Guide Section 4.7.1 Method 1.
- CD 08 is simulated in the Lake Hancock Watershed Model. The discharge rates are based on the output from the Lake Hancock Watershed Model.
- CD 13 is simulated in the Peace Creek Watershed Model. The discharge rates are based on the output from the Peace Creek Watershed Model.
- CD 16, CD 20, and CD 25 are simulated in the Haines City Watershed Model. The discharge rates are based on the output from the Haines City Watershed Model.
- CD 22 is simulated in the Haines City Watershed Model; however, the output shows no flow. The discharge rates are estimated based on the existing cross drain diameter per FDOT Drainage Design Guide Section 4.7.1 Method 1.
- Pipe sizes were based on field review if accessible. Otherwise, pipe sizes were based on available watershed model, existing permits, and FDOT straight line diagrams.
- Tailwater was based on crown of pipe.
- Existing slopes were to be maintained if there are culvert extensions.

Along the proposed design, one existing cross drain is recommended to be replaced (CD 13). Based on field review pictures, the existing roadway pavement appears cracking along the cross drainage pipe. Also, the headwalls appear to abut the roadway, a potential safety issue.

While CD 24 is located within the FEMA designated Floodway, the proposed trail is anticipated to be located between the roadway shoulder and the existing cross drain endwall; and therefore, CD 24 is not anticipated to need extension.



The impacted cross drains for Alternative 1 is found in **Table 4-1**. Cross drain analysis are in **Appendix F**.

Table 4-1 Impacted Cross Drains

Cross Drain #	Type	Existing Size	Proposed Size	Existing DHW (50-Year)	Proposed DHW (50-Year)
CD 01	Replacement	24"	30"	151.43	149.94
CD 08	Extension	10.2' x 8.5' CBC	10.2' x 8.5' CBC	141.18	141.18
CD 12	Replacement	36"	42"	151.26	150.84
CD 13	Extension	4' x 3' CBC	4' x 3' CBC	133.62	133.63
CD 16	Extension	6' x 6' CBC	6' x 6' CBC	128.25	128.23
CD 20	Extension	36"	36"	129.13	129.14
CD 22	Extension	18"	18"	130.82	130.82
CD 25	Extension	30"	30"	126.19	126.19

There is an existing pond on US Hwy 17-92 and C Street, adjacent to the Burger King, that the proposed design will impact and will require further evaluation during the final design.

4.2 Floodplain Impact and Level of Encroachment

The FEMA FIRM data was used to determine the locations of potential floodplain impacts within the project limits. Floodplain impacts of the trail were minor and summarized in the table below. Floodplain Impact Areas (FIA) were calculated as direct or potential impacts due to the construction of the trail. The floodplain impact volume is calculated based on the footprint of the trail plus the width of the estimated tie-down slope and the depth from floodplain elevation to existing ground per LiDAR. Floodplain encroachment will be minimized and any need for compensation will occur in final design. A summary of floodplain impact areas for Alternative 1 is in **Table 4-2**. A floodplain impact map can be found within **Appendix A**.

This project will impact the 100-year floodplain in both transverse and longitudinal ways:

1. Transverse encroachments resulting from the filling floodplain areas due to extension or replacement of existing cross drains associated with proposed trail implementation within the project limits.
2. Longitudinal encroachments resulting from the filling of floodplain areas running parallel to the proposed trail.

The impacts cannot be avoided since the proposed trail will cause widening along the outside of the adjacent roadways. Preliminary design calculations resulted in approximately 0.72 acre-feet of potential floodplain encroachment. During the design phase, every effort should be taken to minimize floodplain impacts.



It should be noted that the proposed trail is anticipated to be located between the roadway shoulder and the existing cross drain endwall near CD 24, which is at a FEMA designated Floodway. Based on the LiDAR data and the published FEMA BFE, no impacts are anticipated.

Table 4-2 Summary of Floodplain Impacts

Floodplain Impact Area (FIA)	Location	Area of Impact (Acre)	Flood Zone	Floodplain Elevation (NAVD 88)	Existing Ground Elevation (NAVD 88)	Depth of Impact (ft)	Volume of Impact (Acre-ft)	Impacted Watershed Model
FIA 1	Canal Crossing on the N side of Ramsgate Rd	0.01	AE	137.4	136.96	0.44	0.00	Lake Hancock
FIA 2	North Side of Old Lake Alfred Road West of W Pierce St.	0.03	AE	131.8	131.52	0.28	0.01	Peace Creek
FIA 3	South Side of EB US-17-92 East of N. Ramona Ave	0.06	AE	130.1	129.70	0.40	0.03	Peace Creek
FIA 4	South Side of EB US-17-92 West of Mosley Rd.	0.01	AE	130.1	129.50	0.60	0.01	Peace Creek
FIA 5	South Side of EB US-17-92 Between Lee Jackson Rd. and Friendly Ct.	0.42	AE	130.1	129.22	0.88	0.37	Peace Creek
FIA 6	South Side of EB US-17-92 East of Friendly Ct.	0.14	AE	130.1	129.77	0.33	0.05	Peace Creek
FIA 7	South Side of EB US-17-92 between Woodland Dr. and Century Dr.	0.38	AE	130.1	129.70	0.40	0.15	Peace Creek
FIA 8	South Side of EB US-17-92 East Sweetwater Club Blvd.	0.05	AE	127.5	127.15	0.35	0.02	Peace Creek & Haines City
FIA 9	South Side of EB US-17-92 East Sweetwater Club Blvd.	0.00	AE	127.8	127.72	0.08	0.00	Peace Creek & Haines City
FIA 10	South Side of EB US-17-92 between Dyson Rd. and Watts Dairy Rd.	0.09	AE	128.7	127.75	0.95	0.08	Peace Creek & Haines City
FIA 11	South Side of EB US-17-92 between US hwy 27 and S F St.	0.01	AE	126.2	125.97	0.23	0.00	Peace Creek & Haines City
Total Impact							0.71	



4.3 Permitting

In general, trail projects are exempt from permitting pursuant to Rule 62-330.051(10) of the Florida Administrative Code. However, after discussing with SWFWMD, the project will likely require an Individual Permit due to wetland impacts. With respect to stormwater, SWFWMD concurred to the following:

- Since this is a trail, the project is not required to meet treatment and attenuation requirements as long as there is no loss in treatment function from an existing system. Any loss of informal treatment will need to be addressed during the final design
- Utilizing the watershed models is a valid way to evaluate floodplain impacts
- Even though the majority of the floodplain impacts are at cross drain extensions and are generally exempt, the project should be evaluated on the cumulative floodplain impacts

The SWFWMD meeting minutes can be found in **Appendix G**.

In addition to compliance with state permitting regulations for stormwater management systems and work in, on, or over wetlands and surface waters, compliance with federal regulations for projects involving work within Waters of the US is also required. The United States Army Corps of Engineers (USACE) regulates actions within Waters of the United States (US) (jurisdictional wetlands and surface waters). Any work proposing to impact Waters of the US requires coordination with the USACE.

4.4 Risk Evaluation

As mentioned previously, the project has minimal encroachments on the floodplain. There is no change in risk as the proposed drainage system follows FDOT drainage criteria. Because of these actions, no additional risk is anticipated to transportation infrastructure, highway users or residents.

4.5 Minimal Encroachment

Per FDOT PD&E Manual, Part 2, Chapter 13 Floodplains, if a project has minimal impacts due to the floodplain encroachments, then the Location Hydraulics Report (LHR) should discuss the following items:

- A. General description of the project including location, length, existing and proposed typical sections, drainage basins and cross drains.*

Refer to Section 3 and 4 of this report for existing and proposed conditions of the project.

- B. Determination of whether the proposed action is in the base floodplain.*



The proposed action is in the base floodplain. Refer to Section 4.2 of this report and the Floodplain Impact Area Map in **Appendix A**.

C. The history of flooding of the existing facilities and/or measures to minimize any impacts due to the proposed improvements.

There are no known existing flooding in the project area. Floodplain encroachment due to cross drain extensions are unavoidable. During design, floodplain encroachment should be looked at cumulatively and evaluated for possible floodplain cutting to offset proposed trail impacts.

D. Determination of whether the encroachment is longitudinal or transverse, and if it is a longitudinal encroachment, an evaluation and discussion of practicable avoidance alternatives.

This project will introduce transverse and longitudinal encroachment to the floodplain. Transverse encroachment is due to cross drain extensions. Longitudinal encroachment is due to proposed trail parallel to roadway and filling into floodplain. During design, floodplain encroachment should be looked at cumulatively and evaluated for possible floodplain cutting to offset proposed trail impacts.

E. The practicability of avoidance alternatives and/or measures to minimize impacts.

Floodplain encroachment due to cross drain extensions are unavoidable. During design, floodplain encroachment should be looked at cumulatively and evaluated for possible floodplain cutting to offset proposed trail impacts.

F. Impact of the project on emergency services and evacuation.

Emergency services and evacuation routes will not be impacted. Proposed cross drain extensions will continue to perform similar to existing drainage conditions, resulting in no significant change in flood risk.

G. Impacts of the project on the base flood, likelihood of flood risk, overtopping, location of overtopping, backwater.

No overtopping will occur. Proposed cross drains will be extended or replaced and will continue to perform similar to existing drainage conditions, resulting in no significant change in flood risk. This will be determined in the design phase.

H. Determination of the impact of the project on regulatory floodways, if any, and documentation of coordination with FEMA and local agencies to determine the requirements for the project to be developed consistent with the regulatory floodway.



There is one regulatory floodway within the project limits. No impacts are anticipated.

- I. *The impacts on natural and beneficial floodplain values, and measures to restore and preserve these values (this information may also be addressed as part of the wetland impact evaluation and recommendations).*

Refer to the Old Dixie Trail PD&E Natural Resource Evaluation.

- J. *Consistency of the project with the local floodplain development plan or the land use elements in the Local Government Comprehensive Plan (LGCP), and the potential of encouraging development in the base floodplain.*

This project remains consistent with local floodplain development plans as it will at a minimum, maintain existing drainage conditions. This project does not change the potential of encouraging development within the base floodplain as it will at a minimum, maintain existing drainage conditions.

- K. *Measures to minimize floodplain impacts associated with the project, and measures to restore and preserve the natural and beneficial floodplain values impacted by the project.*

Floodplain impacts were analyzed in this report. Any unavoidable impacts to the floodplain will be addressed during the final design phase.

- L. *A map showing project, location and impacted floodplains. A FIRM Map should be used if available. If not, other maps (e.g., US Geological Survey (USGS), USACE, Soil Conservation Service (SCS), Bureau of Land Management, U.S. Forest Service, or best available information from the WMDs) may be used. Copies of applicable maps should be included in the appendix.*

Refer to **Appendix A** for project maps and **Appendix B** for FIRM Maps.

- M. *Results of any risk assessment performed.*

Proposed drainage conditions will perform similar to existing drainage conditions, resulting in no significant change in flood risk.



5 CONCLUSION

Modification to existing drainage structures (extending cross drains) that will result in an insignificant change in their capacity to carry floodwater. These modifications will cause minimal increases in flood heights and flood limits which will not result in any significant adverse impacts on the natural and beneficial floodplain values or any significant change in flood risks or damage. There will be no significant change in the potential for interruption or termination of emergency service or emergency evacuation routes as the result of modifications to existing drainage structures.

The proposed structure will perform hydraulically in a manner equal to or greater than the existing structure, and backwater surface elevations are not expected to increase. Thus, there will be no significant adverse impacts on natural and beneficial floodplain values. There will be no significant change in flood risk, and there will not be a significant change in the potential for interruption or termination of emergency service or emergency evacuation routes.

Therefore, it has been determined that this encroachment is not significant.

APPENDIX A:
Exhibits

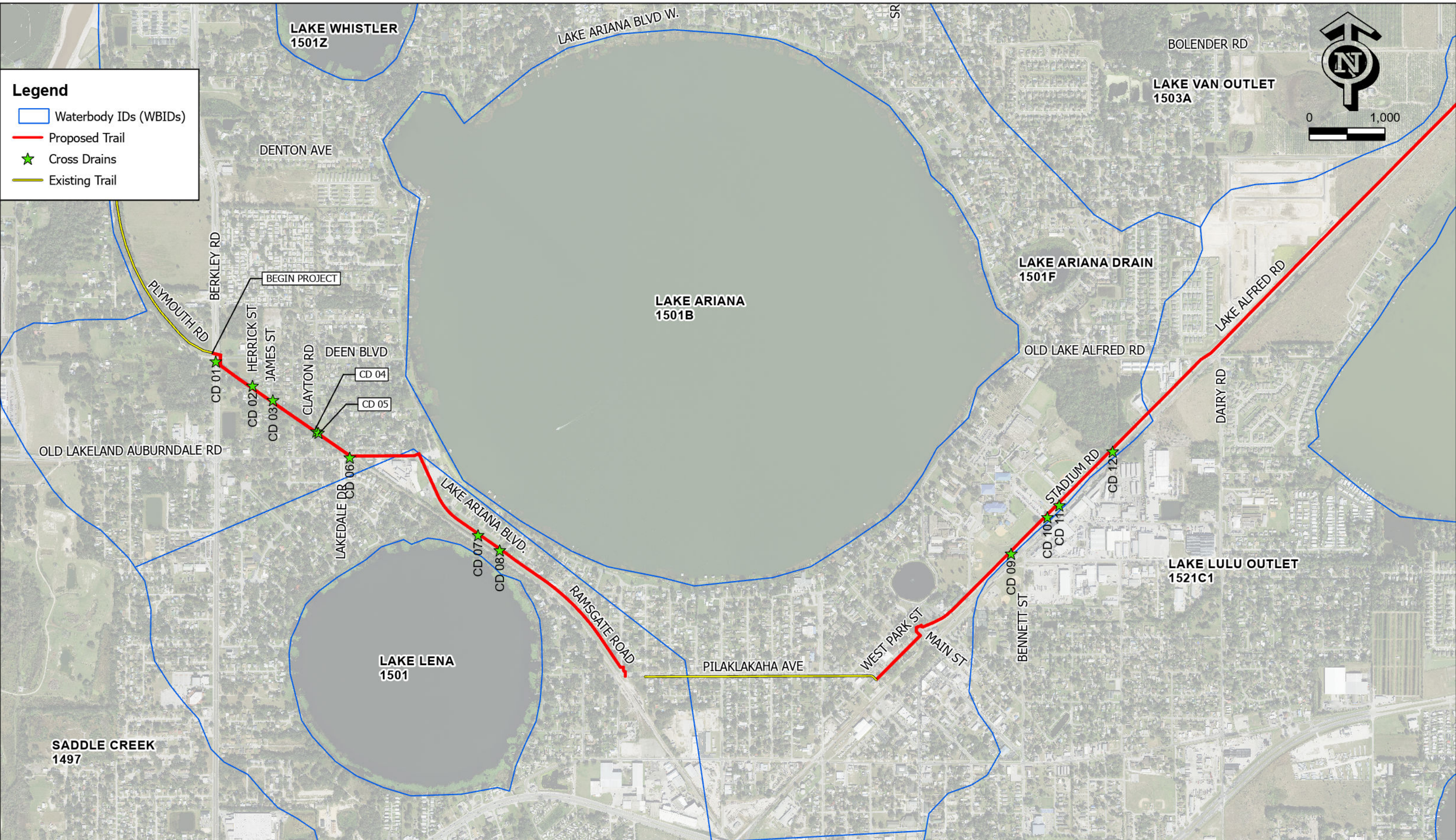

**OLD DIXIE TRAIL
PROJECT DEVELOPMENT AND ENVIRONMENT STUDY**

FPID No: 435391-1-22-01

Drainage Basin Map (1)

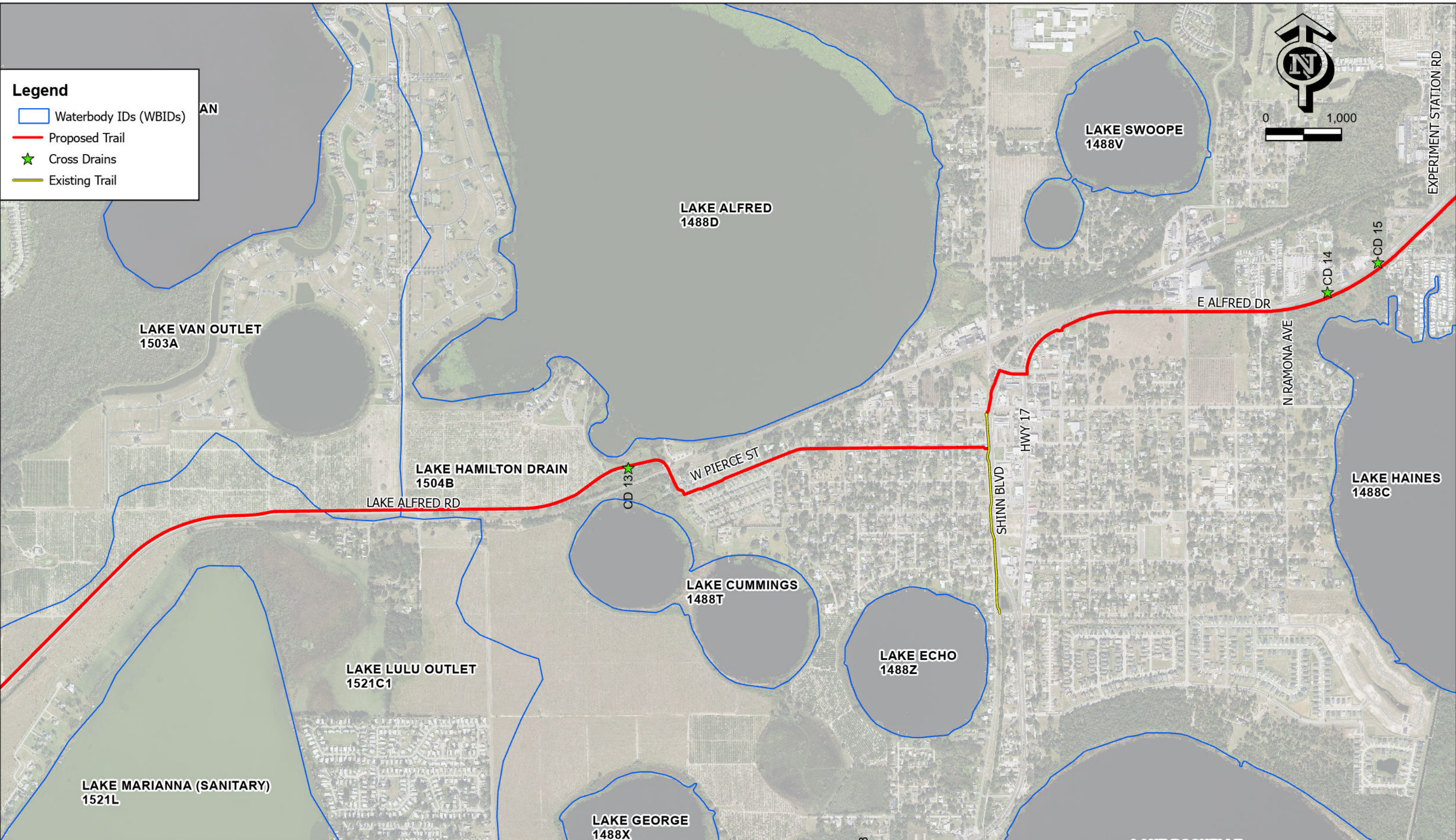

**OLD DIXIE TRAIL
PROJECT DEVELOPMENT AND ENVIRONMENT STUDY**

FPID No: 435391-1-22-01

Drainage Basin Map (2)

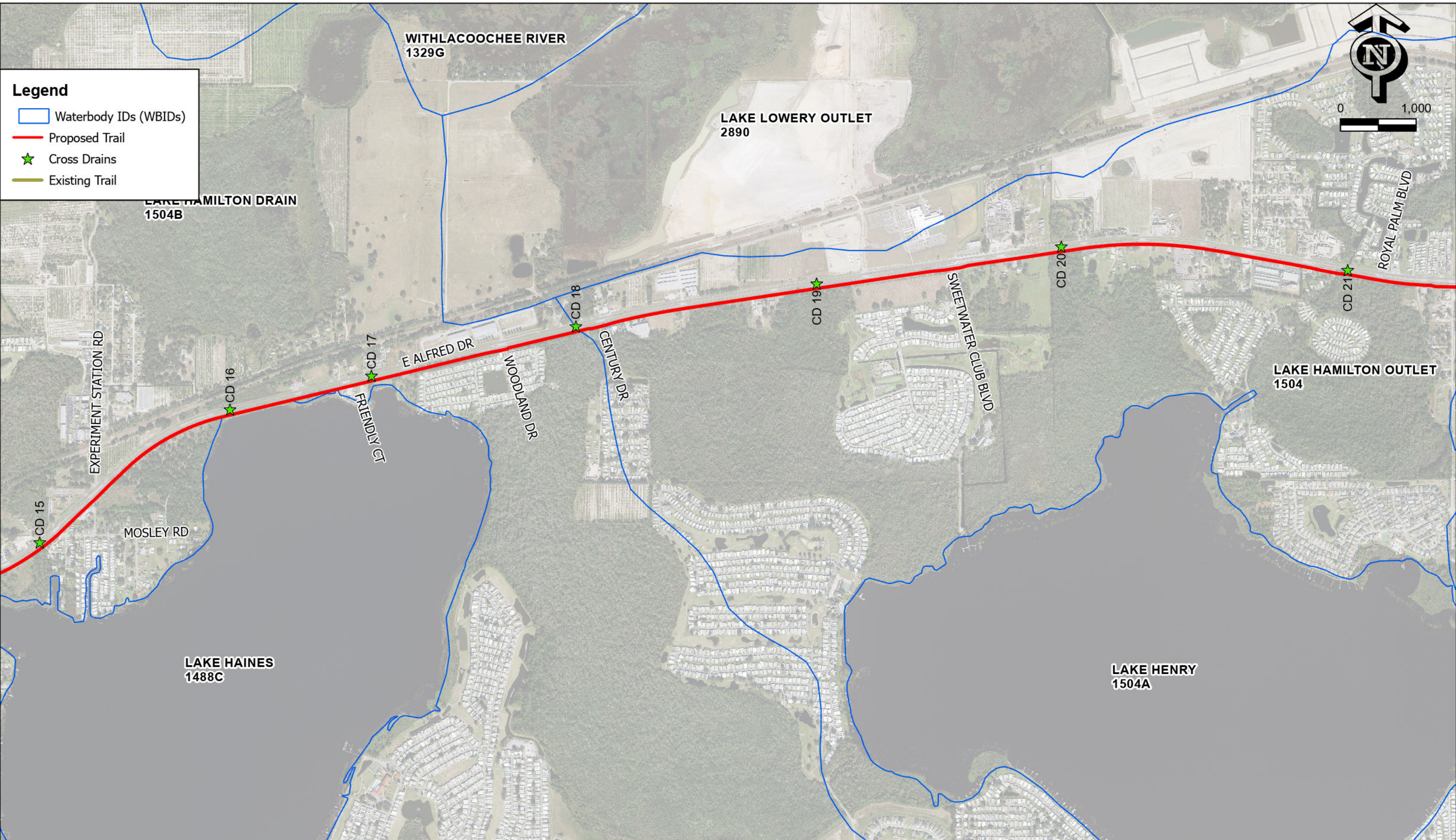

OLD DIXIE TRAIL
PROJECT DEVELOPMENT AND ENVIRONMENT STUDY

FPID No: 435391-1-22-01

Drainage Basin Map (3)

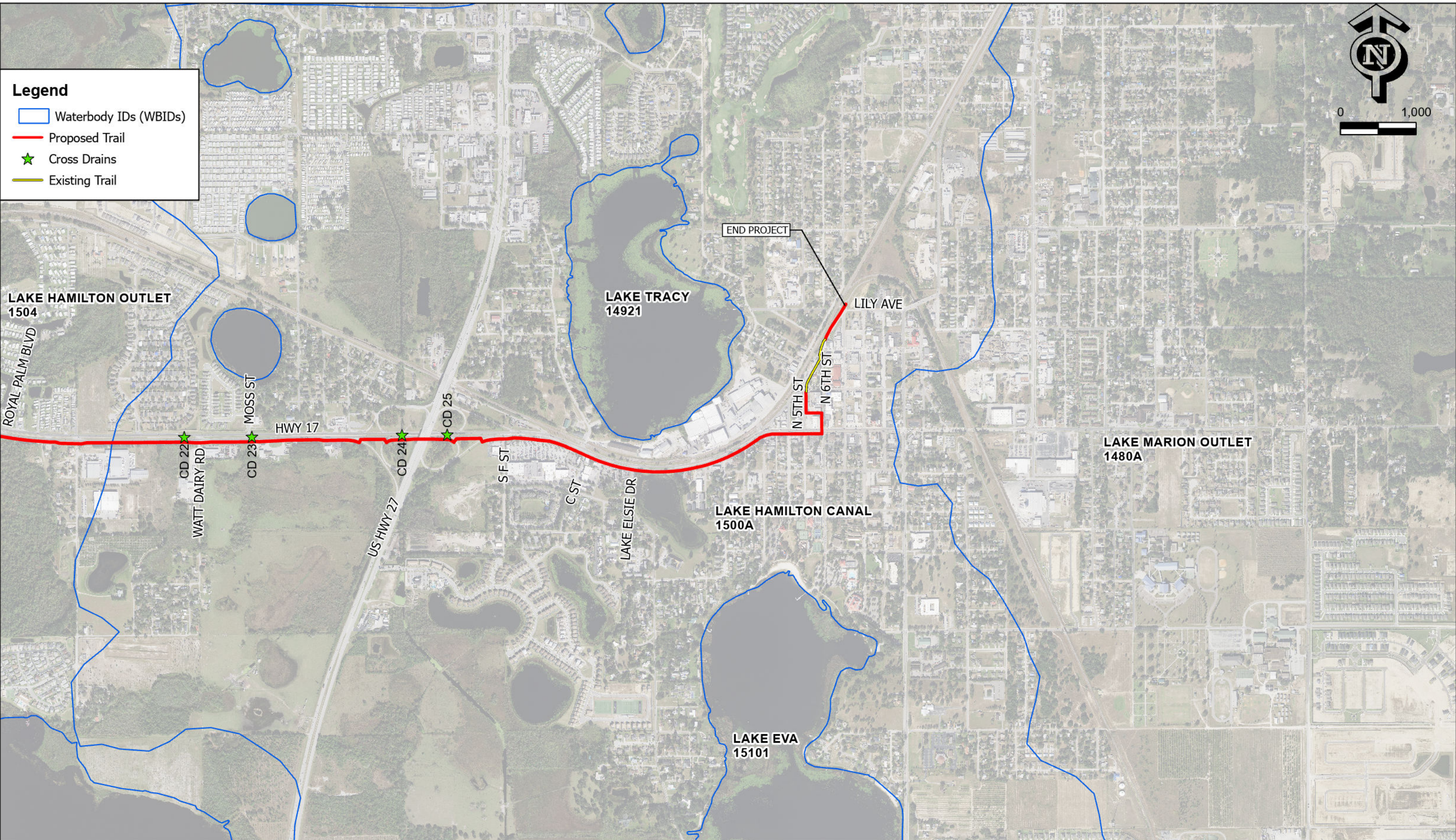

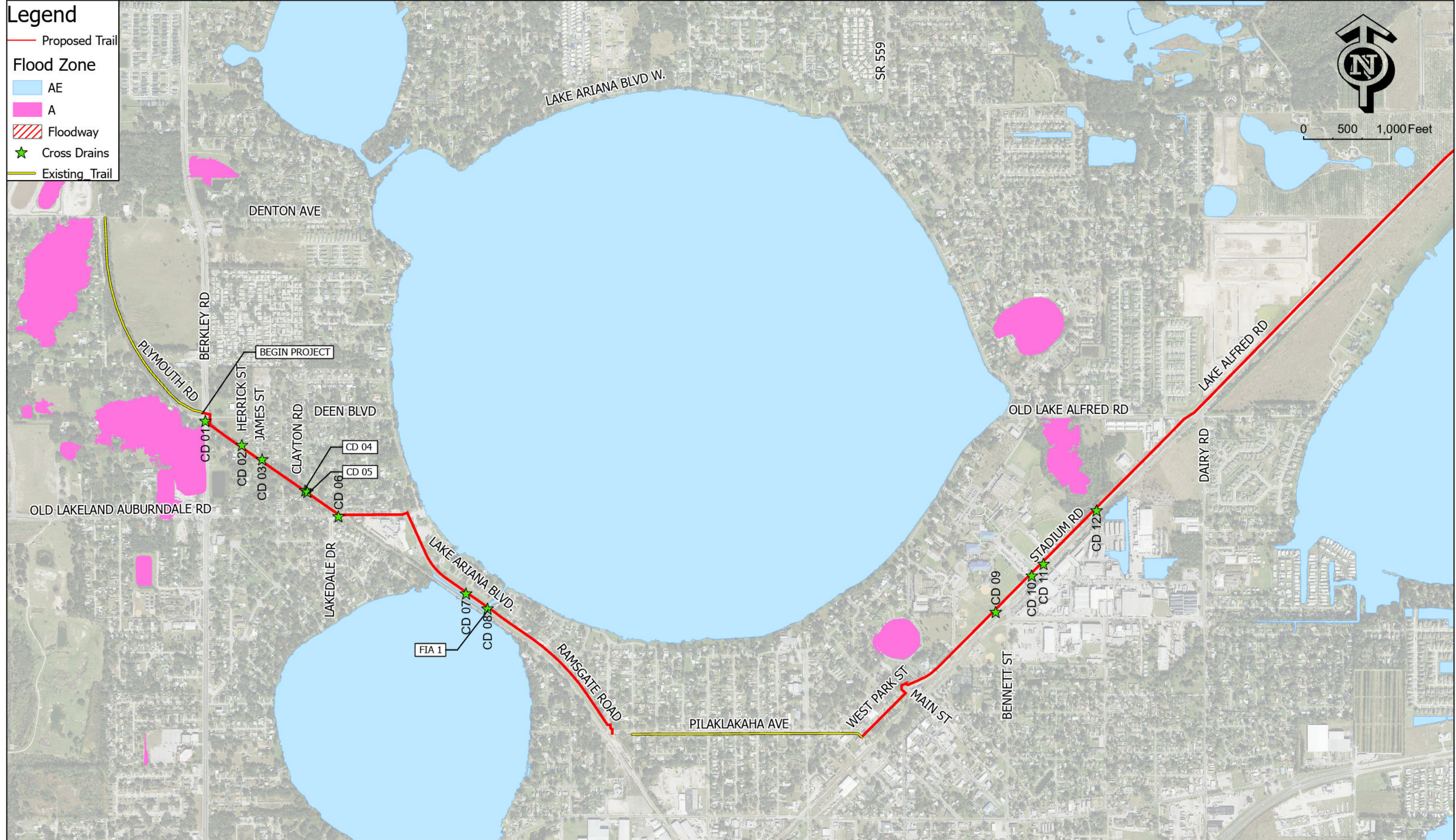

OLD DIXIE TRAIL
PROJECT DEVELOPMENT AND ENVIRONMENT STUDY

FPID No: 435391-1-22-01

Floodplain Impact Area Map (1)

Legend

- Proposed Trail
- Flood Zone**
- AE
- A
- Floodway
- ★ Cross Drains
- Existing Trail



0 500 1,000 Feet

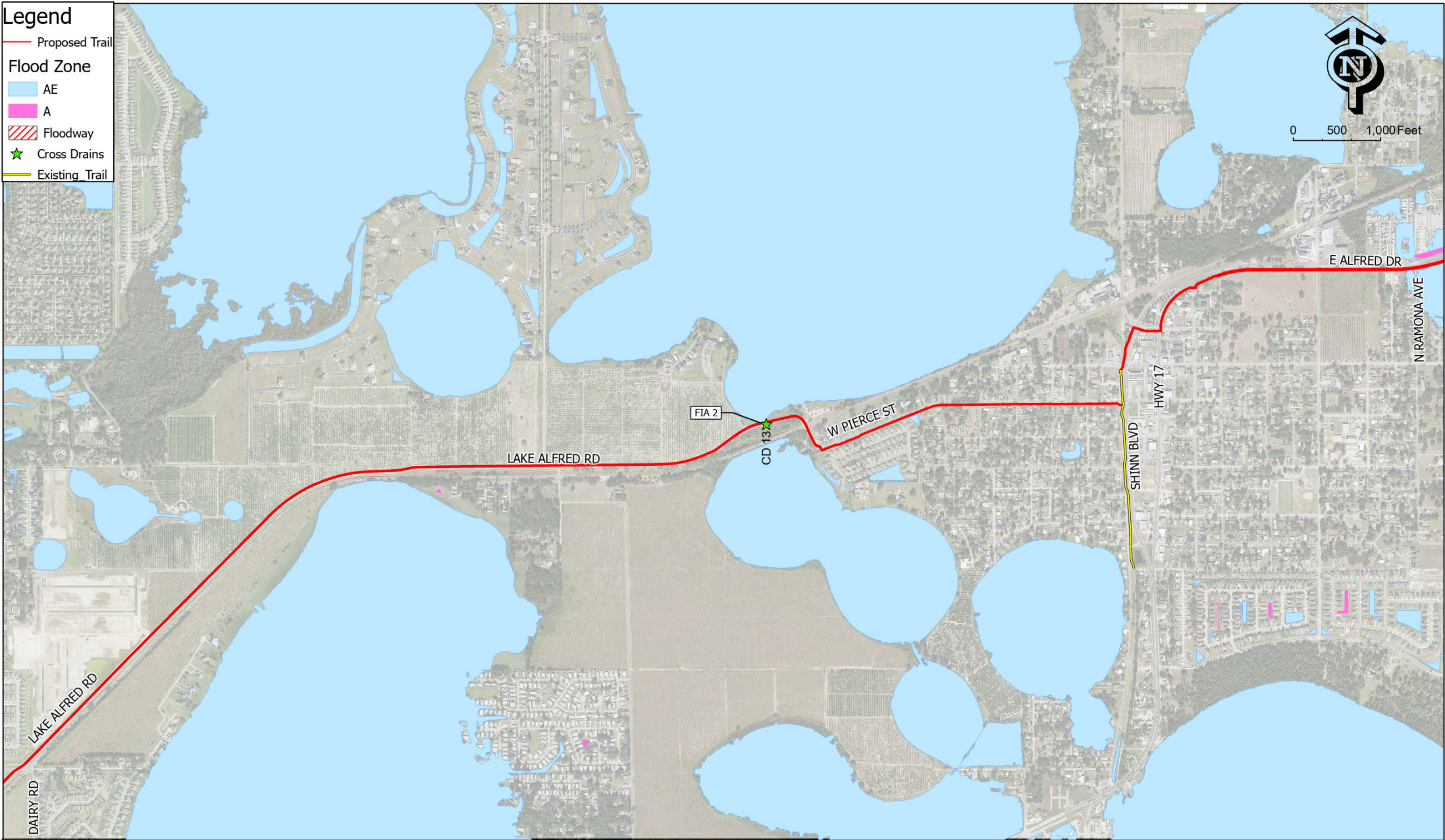

OLD DIXIE TRAIL
 PROJECT DEVELOPMENT AND ENVIRONMENT STUDY

FPID No: 435391-1-22-01

Floodplain Impact Area Map (2)

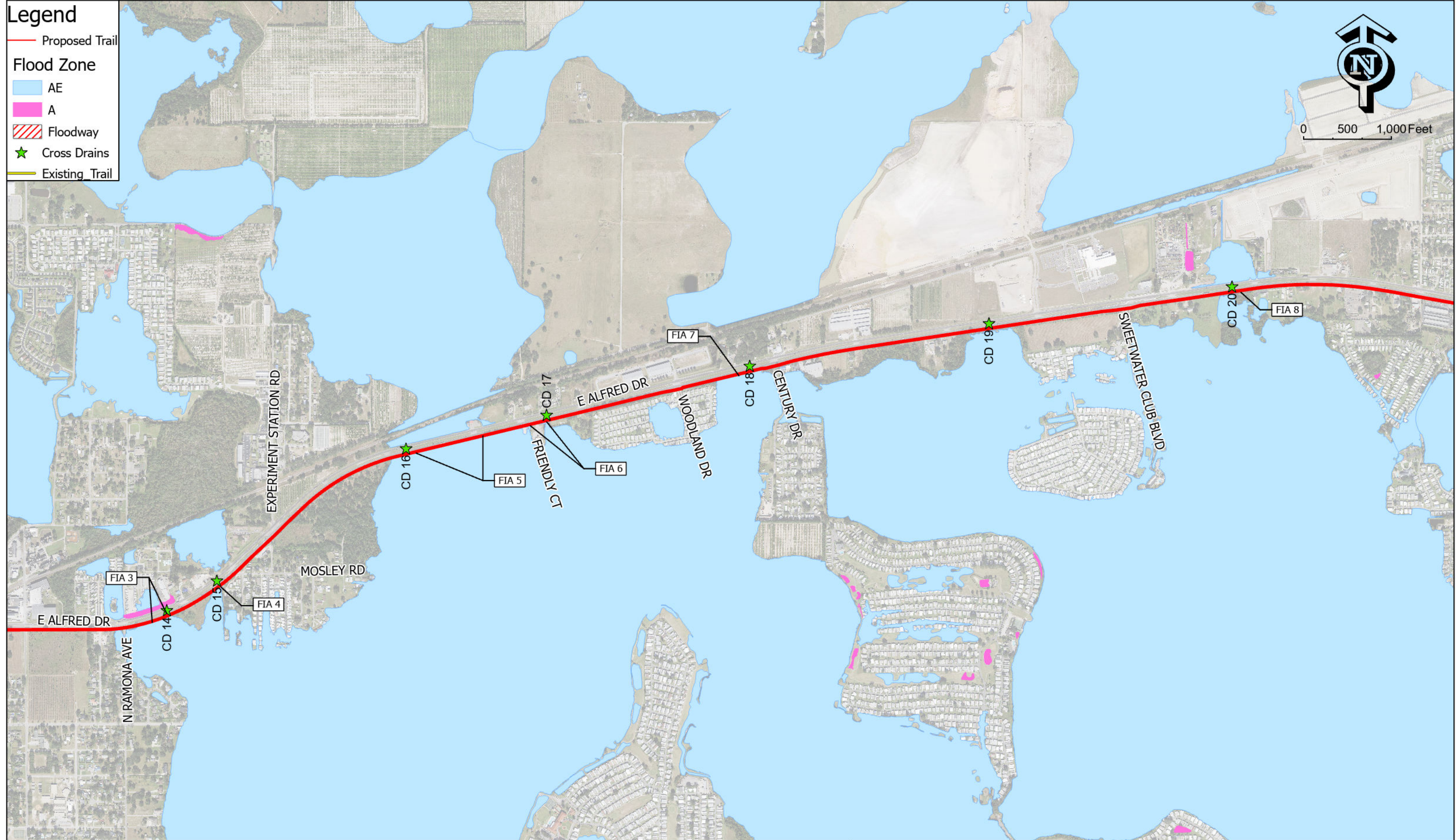

OLD DIXIE TRAIL
PROJECT DEVELOPMENT AND ENVIRONMENT STUDY

FPID No: 435391-1-22-01

Floodplain Impact Area Map (3)

Legend

- Proposed Trail
- Flood Zone**
- AE
- A
- Floodway
- ★ Cross Drains
- Existing Trail

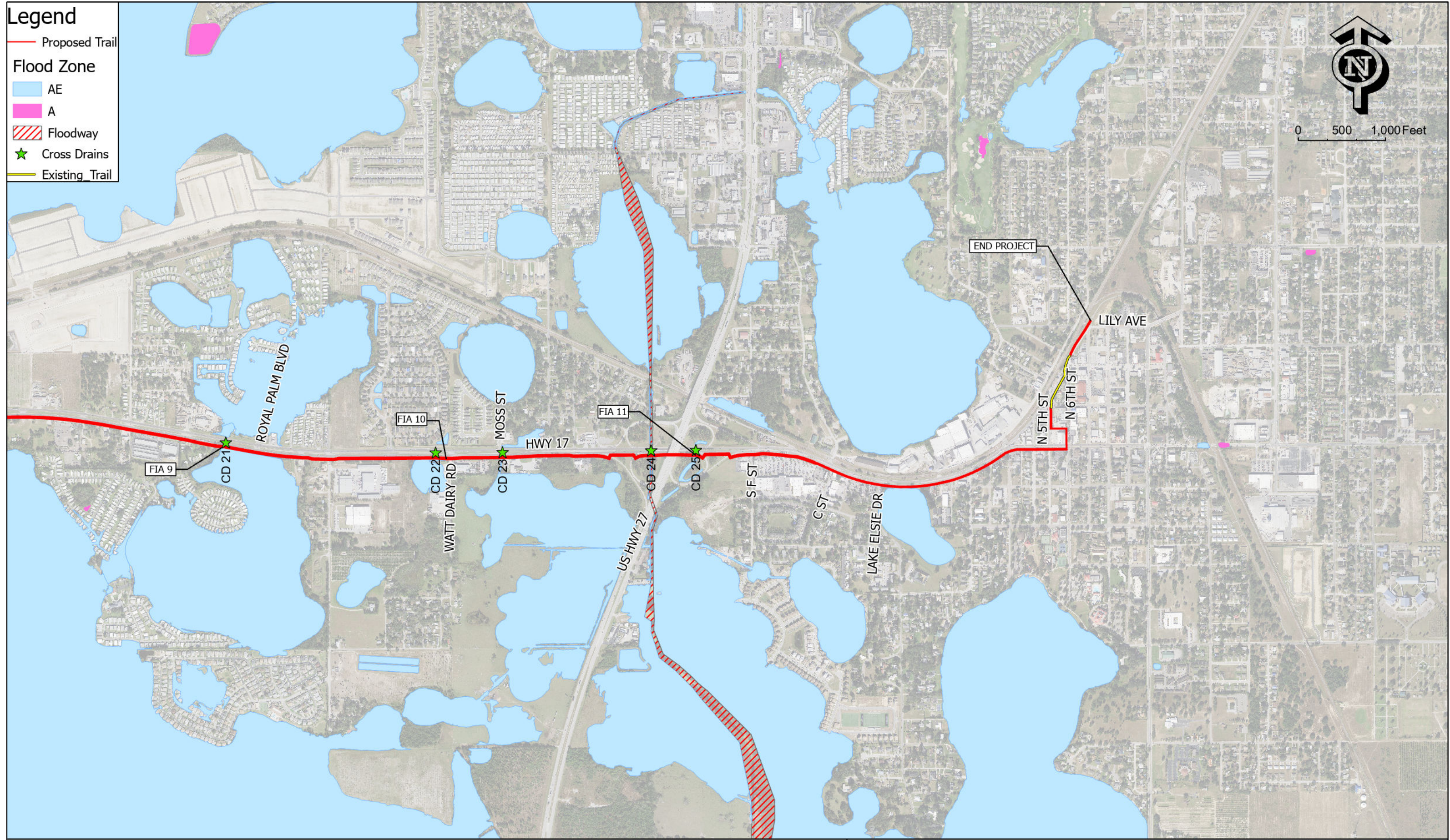
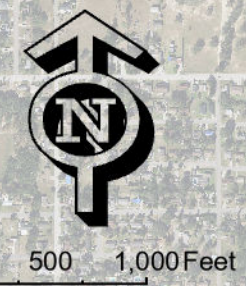

**OLD DIXIE TRAIL
PROJECT DEVELOPMENT AND ENVIRONMENT STUDY**

FPID No: 435391-1-22-01

Floodplain Impact Area Map (4)



Legend

- Preferred Alternative
- - - Existing Trail
- Buffer (150 ft from centerline)
- 1200, RESIDENTIAL MED DENSITY
- 1400, COMMERCIAL AND SERVICES
- 2600, OTHER OPEN LANDS
- 5300, RESERVOIRS
- 6530, INTERMITTENT PONDS
- 8100, TRANSPORTATION

Land Use
within 150-feet from the Preferred Alternative

Old Dixie Trail PD&E
Financial Project ID 435391-1-22-01
ETDM Project No. 14328

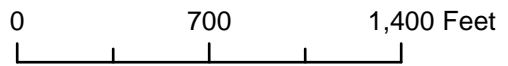



Legend

- Preferred Alternative
- Existing Trail
- Buffer (150 ft from centerline)
- 1200, RESIDENTIAL MED DENSITY
- 1400, COMMERCIAL AND SERVICES
- 1500, INDUSTRIAL
- 1800, RECREATIONAL
- 8100, TRANSPORTATION



Land Use
within 150-feet from the Preferred Alternative

Old Dixie Trail PD&E
Financial Project ID 435391-1-22-01
ETDM Project No. 14328

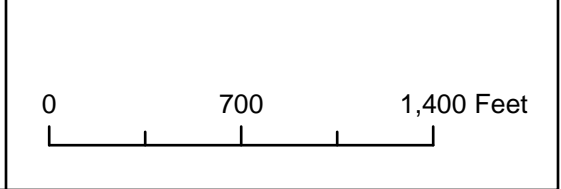

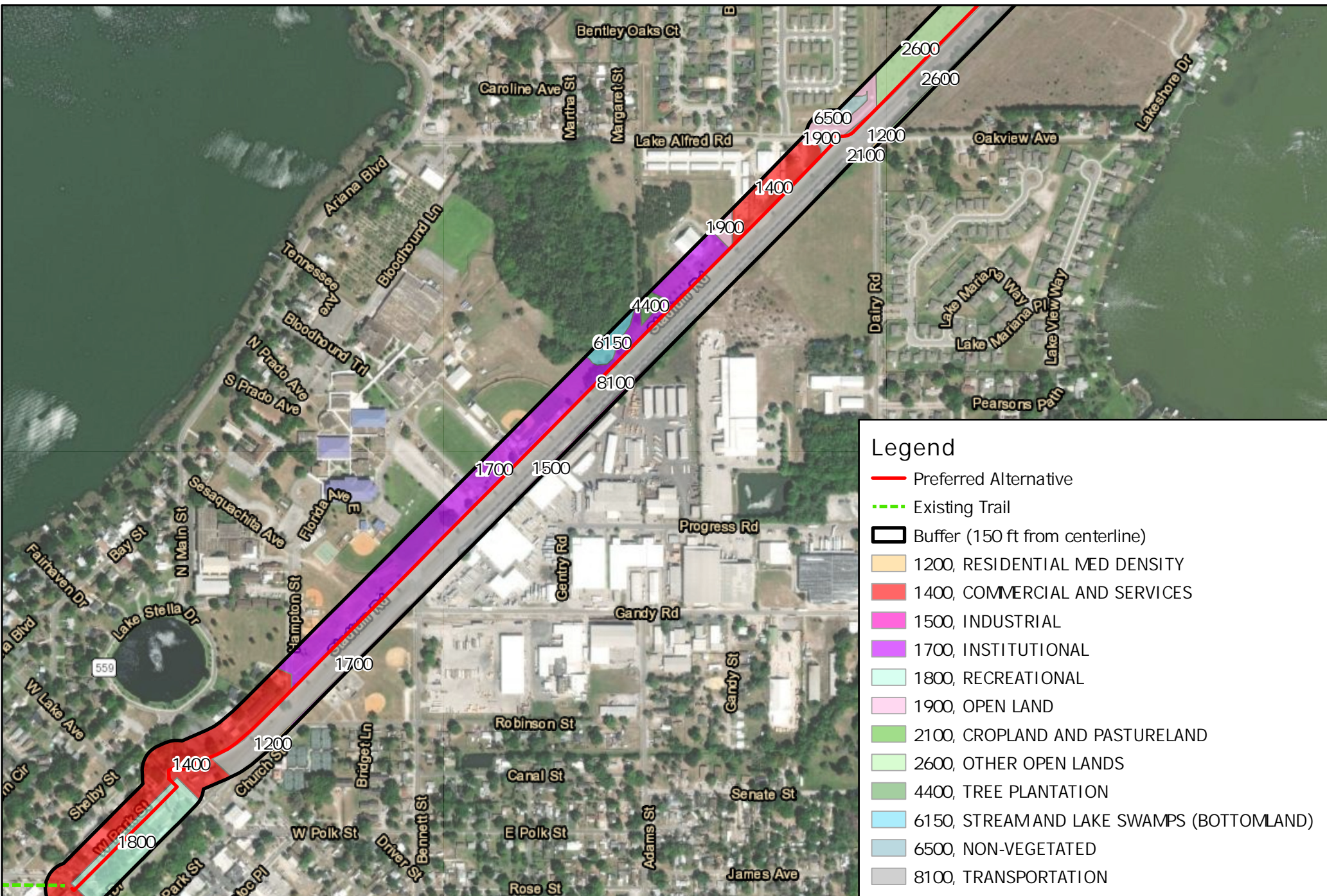

Land Use
within 150-feet from the Preferred Alternative

Old Dixie Trail PD&E
Financial Project ID 435391-1-22-01
ETDM Project No. 14328

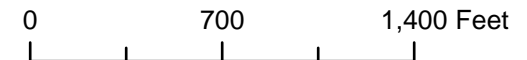

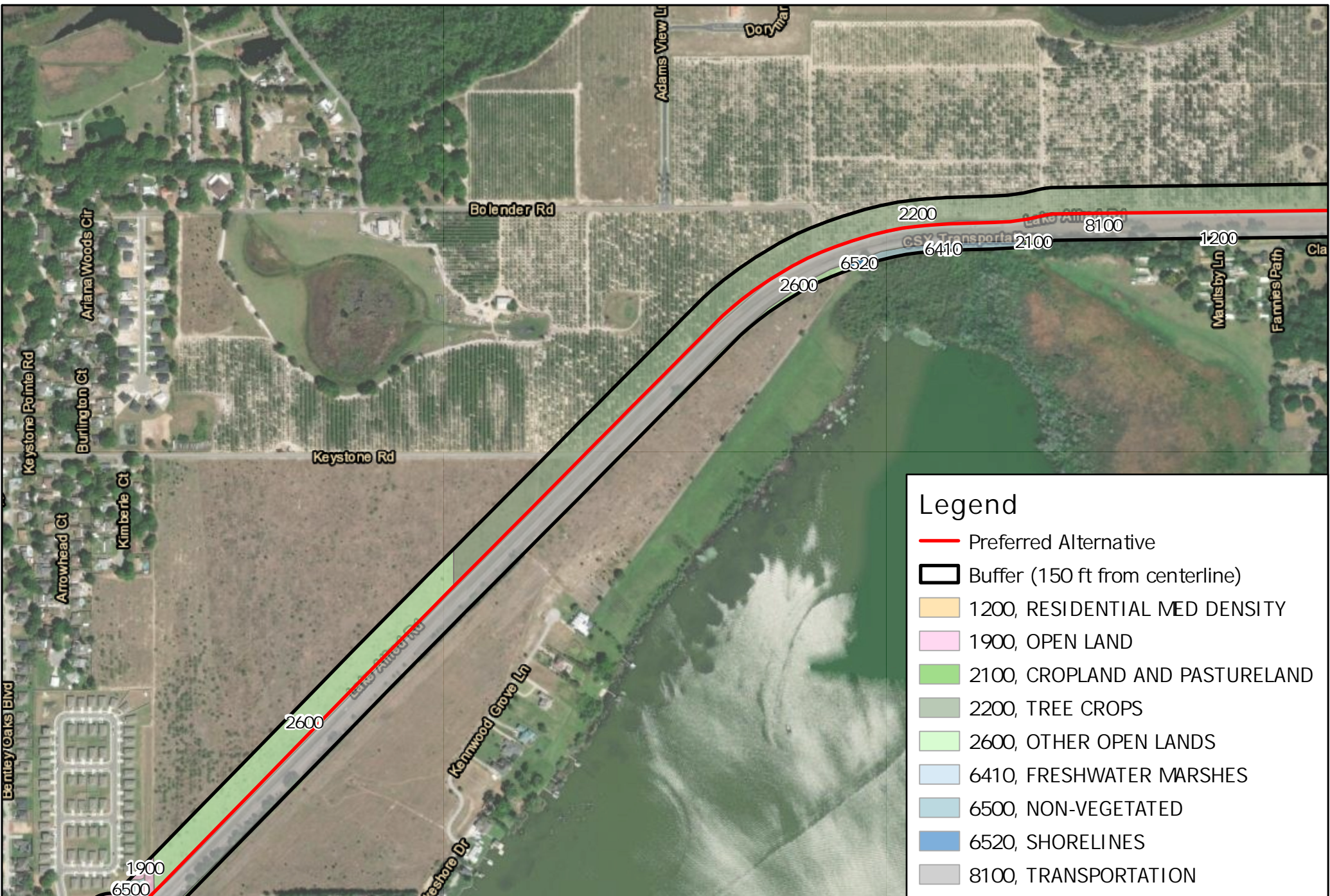

Legend

- Preferred Alternative
- Buffer (150 ft from centerline)
- 1200, RESIDENTIAL MED DENSITY
- 1900, OPEN LAND
- 2100, CROPLAND AND PASTURELAND
- 2200, TREE CROPS
- 2600, OTHER OPEN LANDS
- 6410, FRESHWATER MARSHES
- 6500, NON-VEGETATED
- 6520, SHORELINES
- 8100, TRANSPORTATION



Land Use
within 150-feet from the Preferred Alternative

Old Dixie Trail PD&E
Financial Project ID 435391-1-22-01
ETDM Project No. 14328

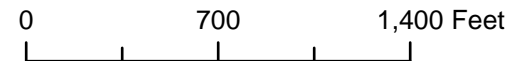

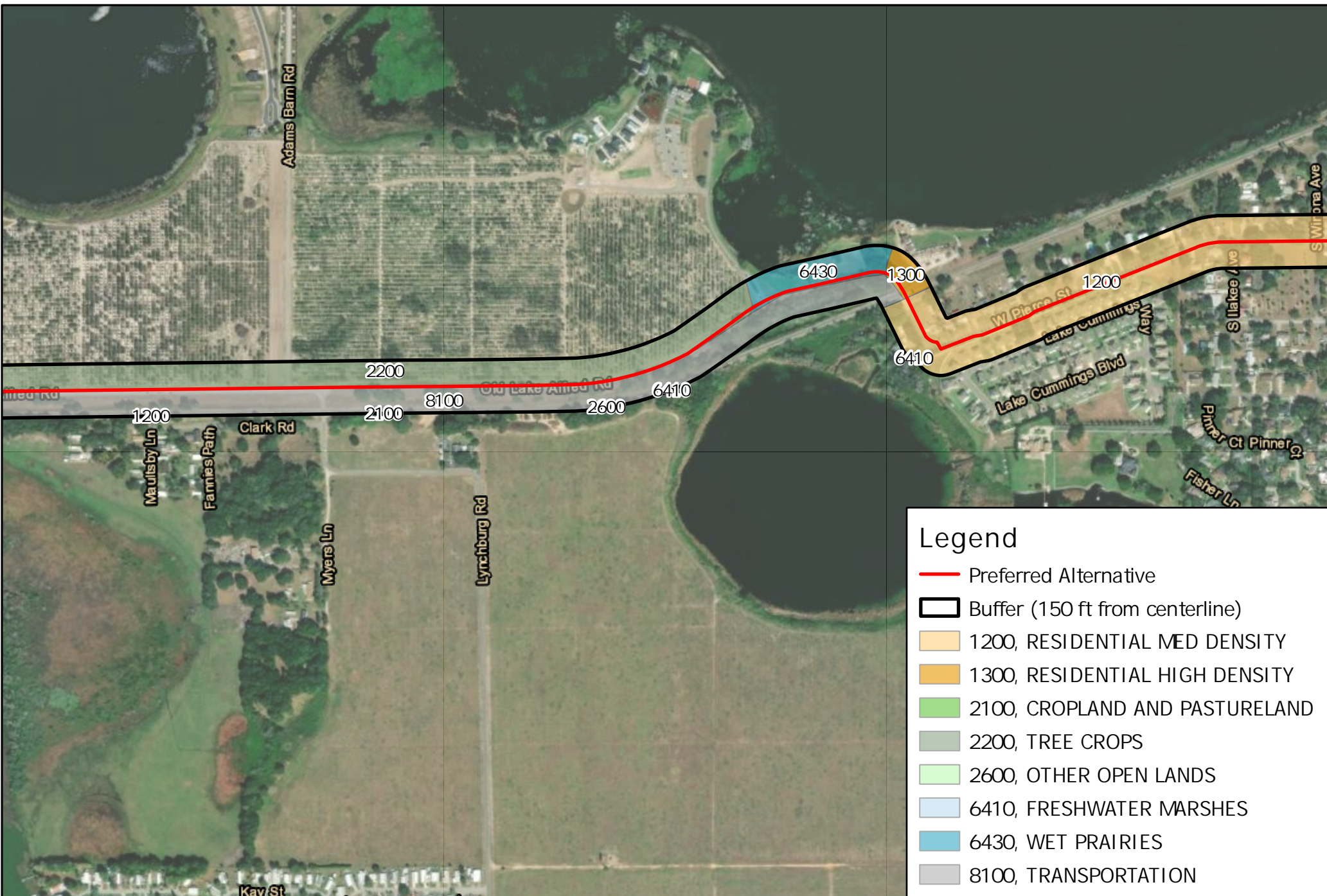

Legend

- Preferred Alternative
- Buffer (150 ft from centerline)
- 1200, RESIDENTIAL MED DENSITY
- 1300, RESIDENTIAL HIGH DENSITY
- 2100, CROPLAND AND PASTURELAND
- 2200, TREE CROPS
- 2600, OTHER OPEN LANDS
- 6410, FRESHWATER MARSHES
- 6430, WET PRAIRIES
- 8100, TRANSPORTATION



Land Use
within 150-feet from the Preferred Alternative

Old Dixie Trail PD&E
Financial Project ID 435391-1-22-01
ETDM Project No. 14328

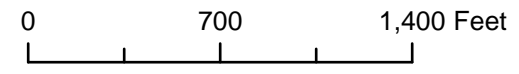

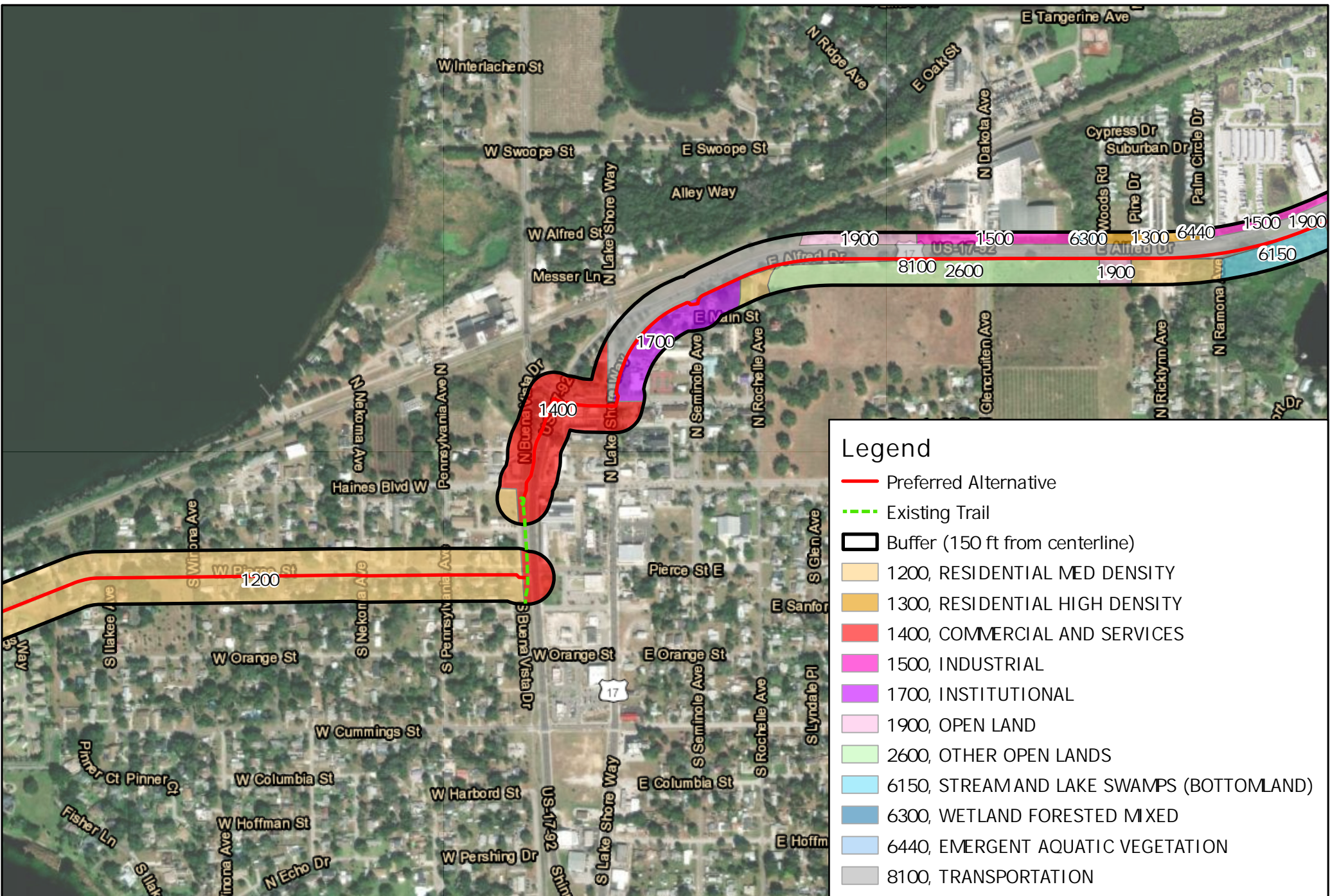

Legend

- Preferred Alternative
- - - Existing Trail
- Buffer (150 ft from centerline)
- 1200, RESIDENTIAL MED DENSITY
- 1300, RESIDENTIAL HIGH DENSITY
- 1400, COMMERCIAL AND SERVICES
- 1500, INDUSTRIAL
- 1700, INSTITUTIONAL
- 1900, OPEN LAND
- 2600, OTHER OPEN LANDS
- 6150, STREAM AND LAKE SWAMPS (BOTTOMLAND)
- 6300, WETLAND FORESTED MIXED
- 6440, EMERGENT AQUATIC VEGETATION
- 8100, TRANSPORTATION



Land Use
within 150-feet from the Preferred Alternative

Old Dixie Trail PD&E
Financial Project ID 435391-1-22-01
ETDM Project No. 14328

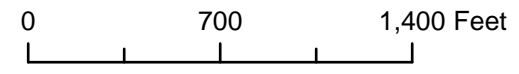

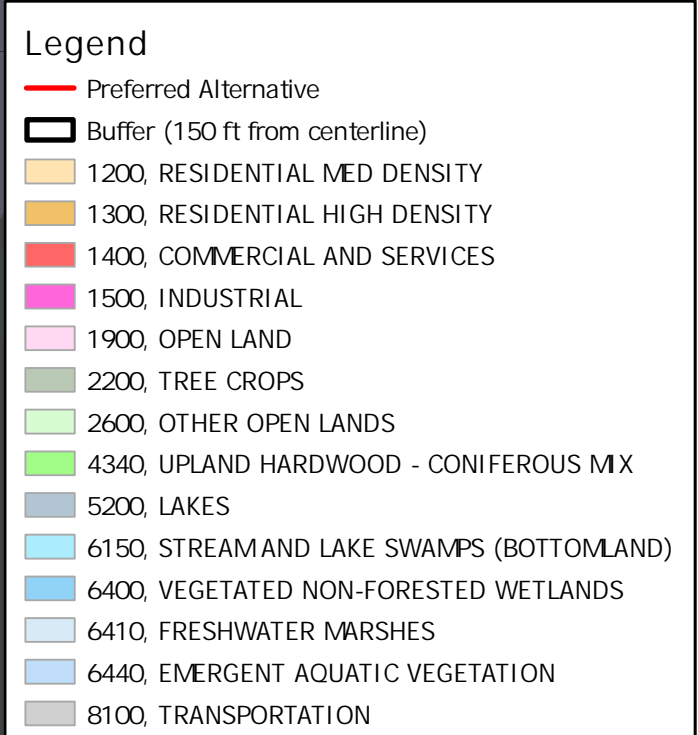
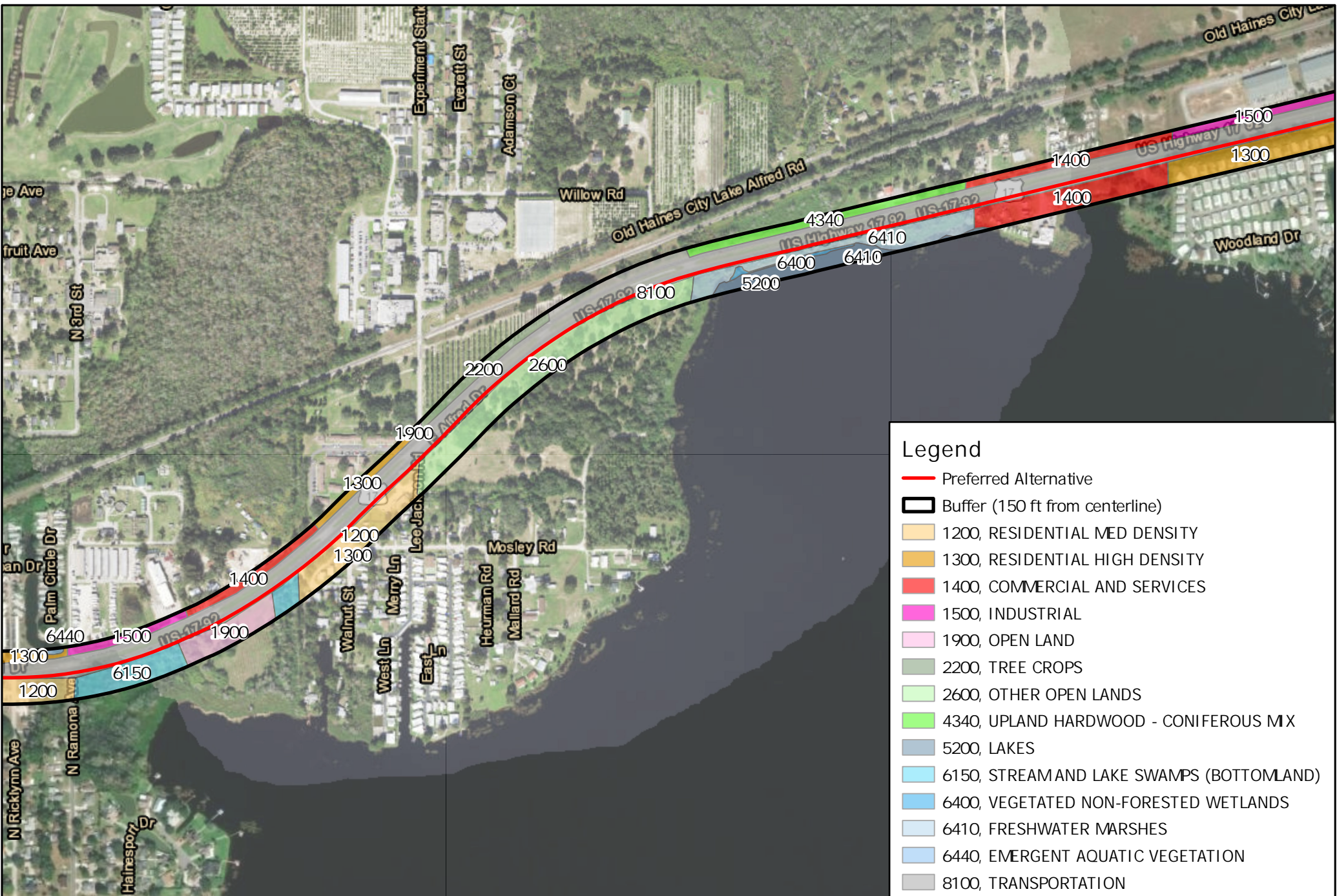

Land Use
within 150-feet from the Preferred Alternative

Old Dixie Trail PD&E
Financial Project ID 435391-1-22-01
ETDM Project No. 14328

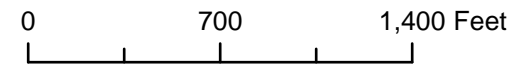

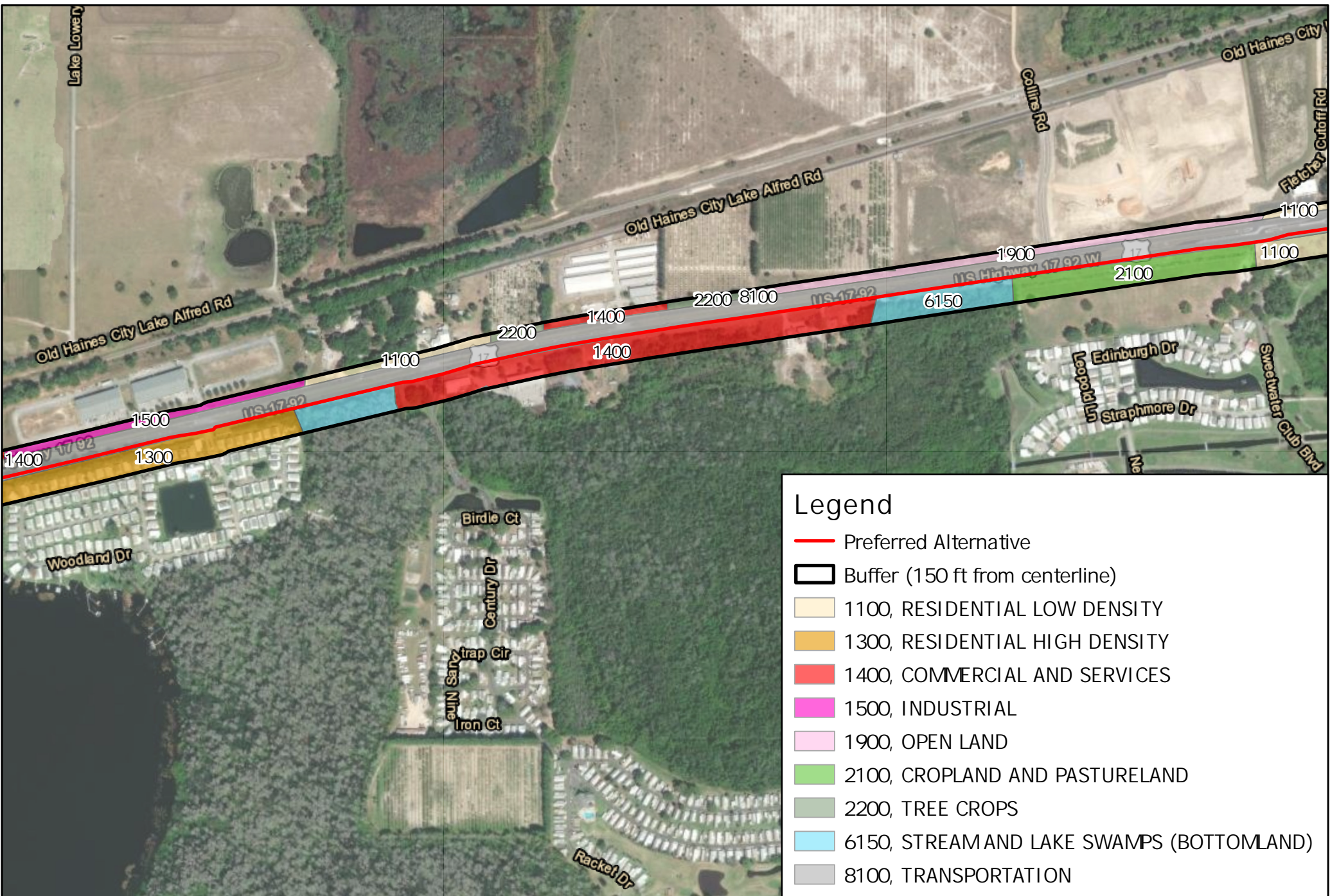

Legend

- Preferred Alternative
- Buffer (150 ft from centerline)
- 1100, RESIDENTIAL LOW DENSITY
- 1300, RESIDENTIAL HIGH DENSITY
- 1400, COMMERCIAL AND SERVICES
- 1500, INDUSTRIAL
- 1900, OPEN LAND
- 2100, CROPLAND AND PASTURELAND
- 2200, TREE CROPS
- 6150, STREAM AND LAKE SWAMPS (BOTTOMLAND)
- 8100, TRANSPORTATION



Land Use
within 150-feet from the Preferred Alternative

Old Dixie Trail PD&E
Financial Project ID 435391-1-22-01
ETDM Project No. 14328

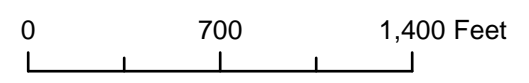

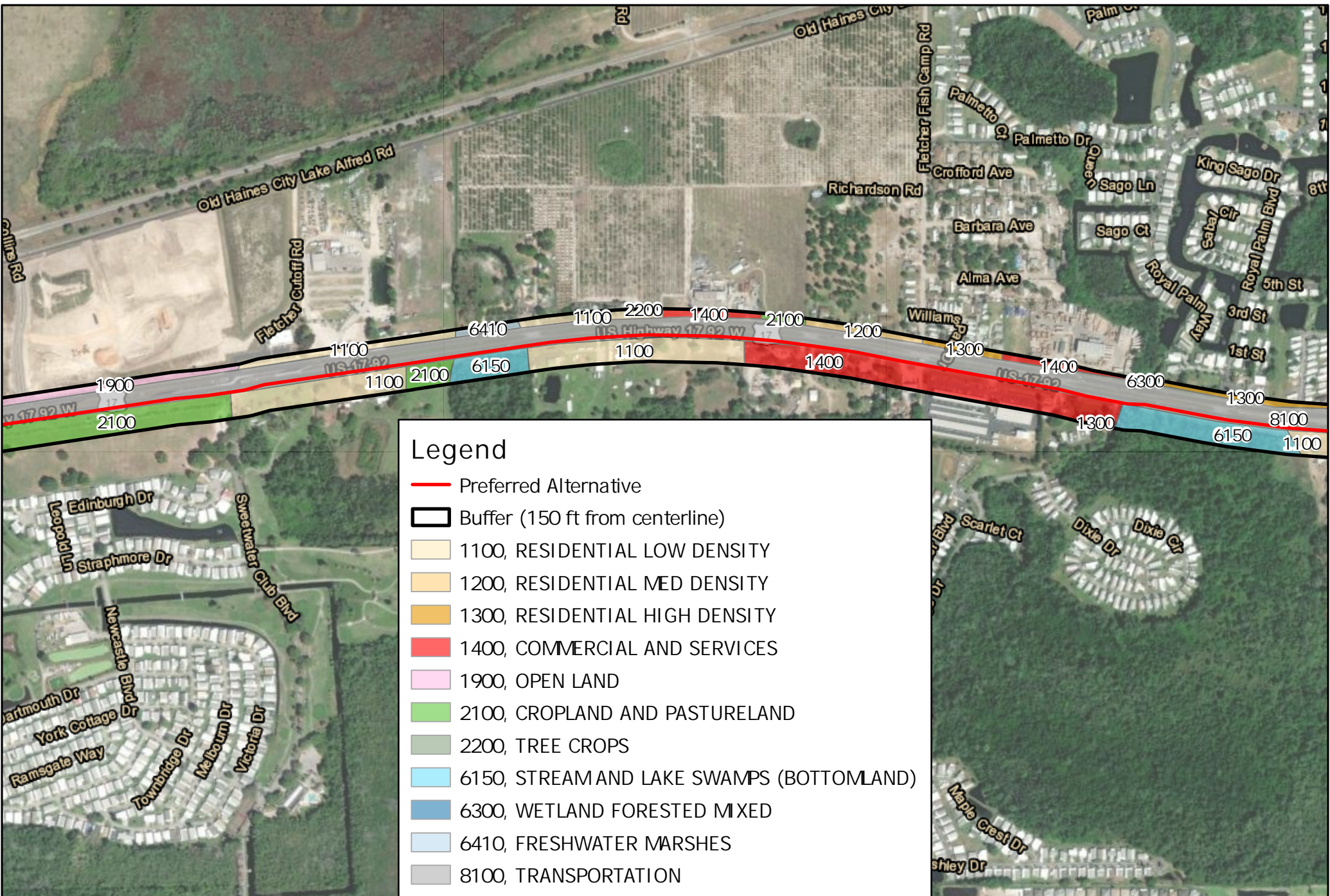

Legend

- Preferred Alternative
- Buffer (150 ft from centerline)
- 1100, RESIDENTIAL LOW DENSITY
- 1200, RESIDENTIAL MED DENSITY
- 1300, RESIDENTIAL HIGH DENSITY
- 1400, COMMERCIAL AND SERVICES
- 1900, OPEN LAND
- 2100, CROPLAND AND PASTURELAND
- 2200, TREE CROPS
- 6150, STREAM AND LAKE SWAMPS (BOTTOMLAND)
- 6300, WETLAND FORESTED MIXED
- 6410, FRESHWATER MARSHES
- 8100, TRANSPORTATION



Land Use
within 150-feet from the Preferred Alternative

Old Dixie Trail PD&E
Financial Project ID 435391-1-22-01
ETDM Project No. 14328

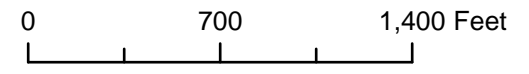

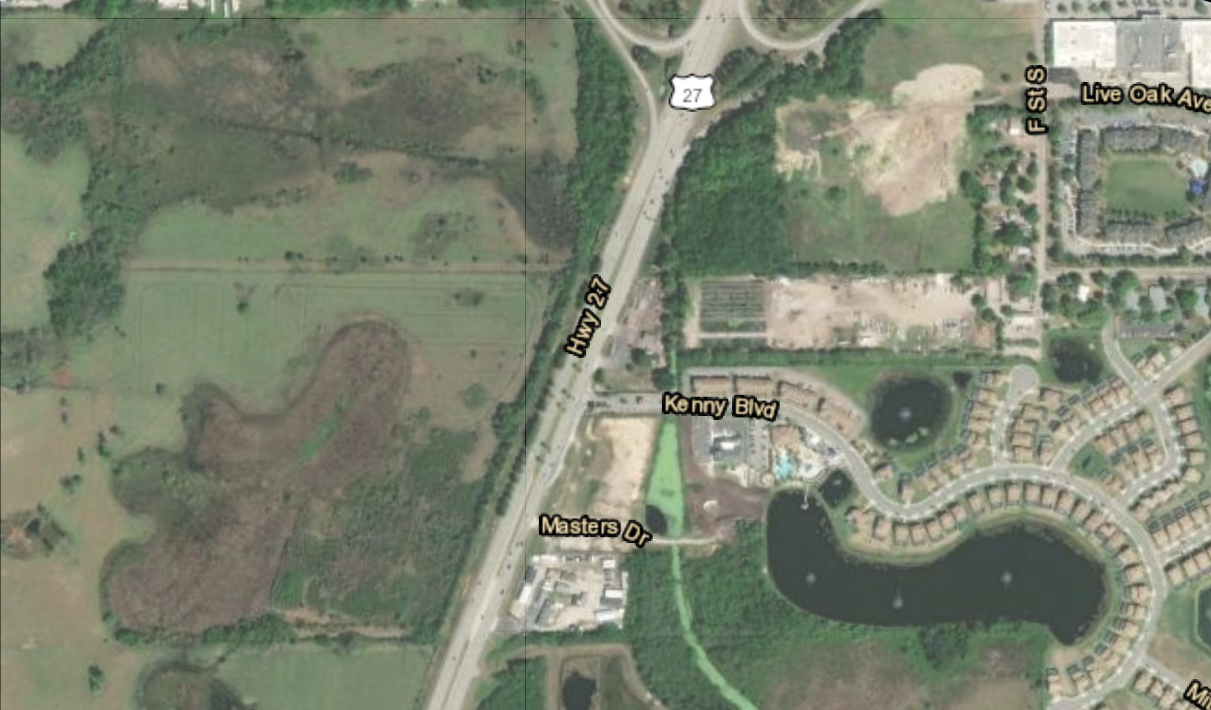
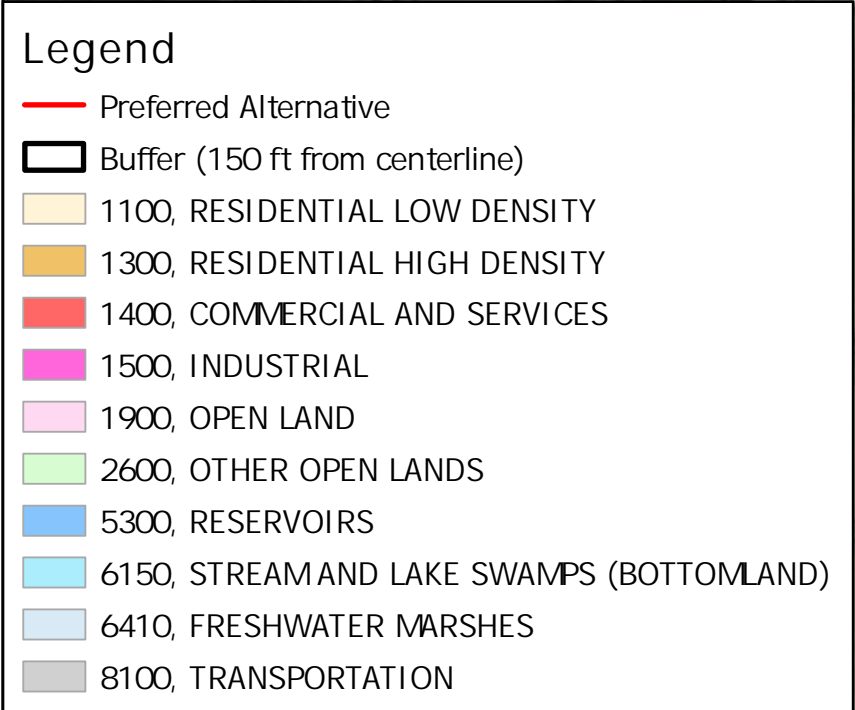
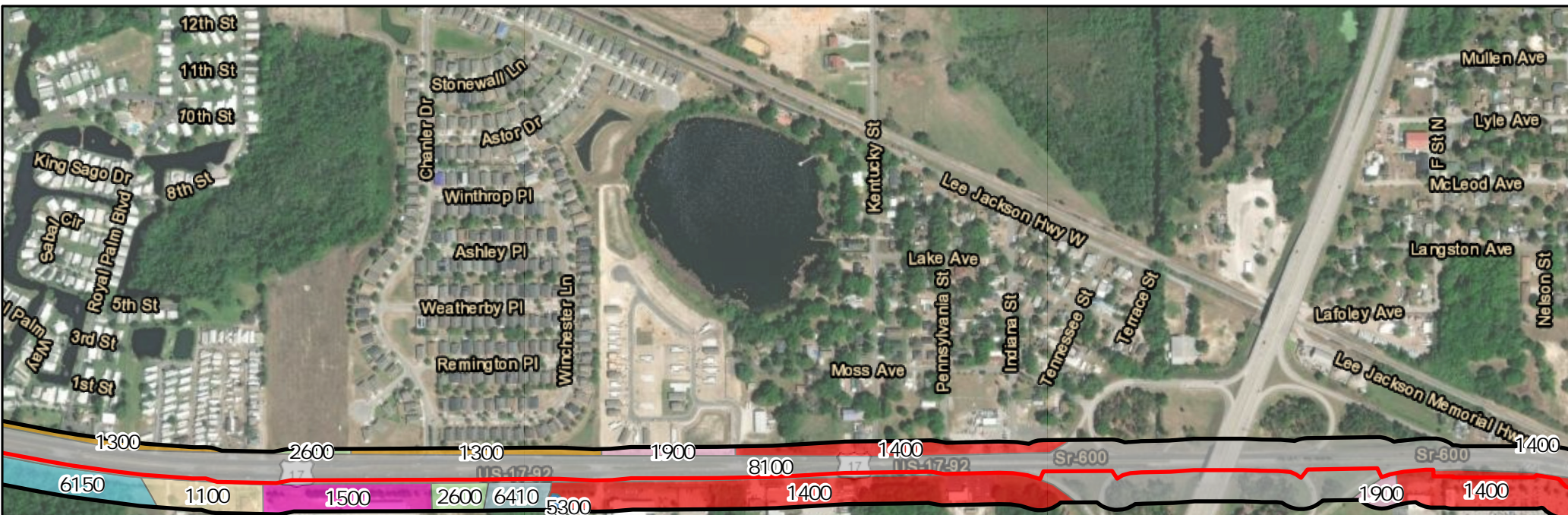

Land Use
within 150-feet from the Preferred Alternative

Old Dixie Trail PD&E
Financial Project ID 435391-1-22-01
ETDM Project No. 14328

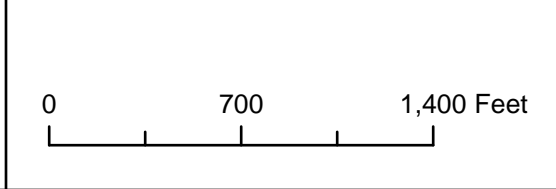

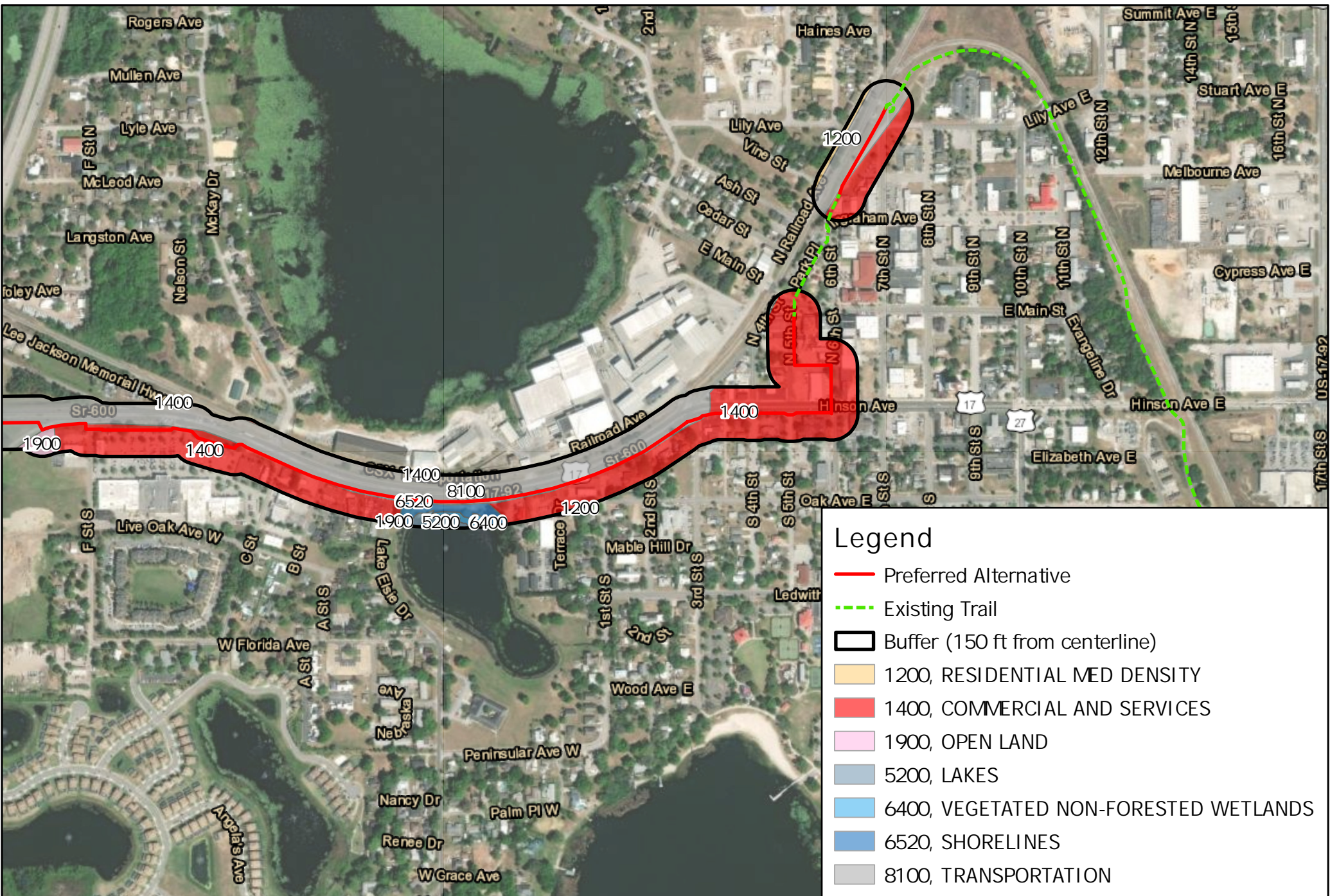

Legend

- Preferred Alternative
- - - Existing Trail
- Buffer (150 ft from centerline)
- 1200, RESIDENTIAL MED DENSITY
- 1400, COMMERCIAL AND SERVICES
- 1900, OPEN LAND
- 5200, LAKES
- 6400, VEGETATED NON-FORESTED WETLANDS
- 6520, SHORELINES
- 8100, TRANSPORTATION



Land Use
within 150-feet from the Preferred Alternative

Old Dixie Trail PD&E
Financial Project ID 435391-1-22-01
ETDM Project No. 14328

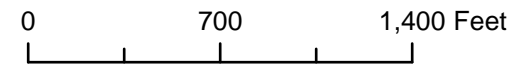

STATE OF FLORIDA
DEPARTMENT OF TRANSPORTATION

TYPICAL SECTION PACKAGE

FINANCIAL PROJECT ID 435391-1-22-01
POLK COUNTY (16020000, 16020102)
OLD DIXIE TRAIL
AUBURNDALE TO HAINES CITY

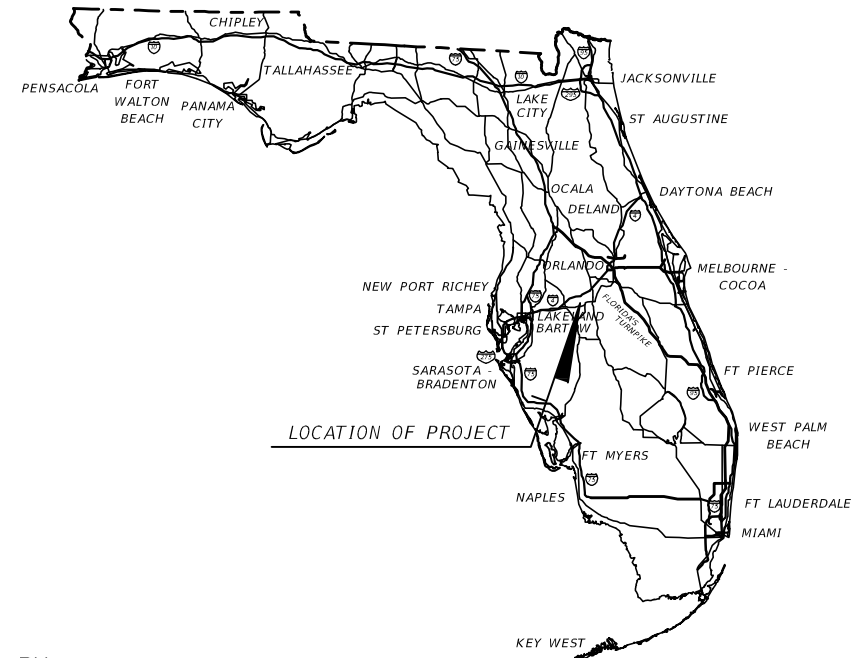

FDOT DISTRICT DESIGN ENGINEER . . . CONCURRING WITH: TYPICAL SECTION ELEMENTS TARGET SPEED DESIGN & POSTED SPEEDS	FDOT DISTRICT TRAFFIC OPERATIONS ENGINEER . . . CONCURRING WITH: TARGET SPEED DESIGN & POSTED SPEEDS
--	---

FDOT DISTRICT INTERMODAL SYSTEMS DEVELOPMENT MANAGER . . . CONCURRING WITH: CONTEXT CLASSIFICATION TARGET SPEED	FDOT DISTRICT STRUCTURES DESIGN ENGINEER . . . CONCURRING WITH: TYPICAL SECTION ELEMENTS TARGET SPEED
--	--

FHWA TRANSPORTATION ENGINEER . . . CONCURRING WITH: TYPICAL SECTION ELEMENTS	LOCAL TRANSPORTATION ENGINEER . . . CONCURRING WITH: TYPICAL SECTION ELEMENTS
---	--

NOT USED . . . CONCURRING WITH:	NOT USED . . . CONCURRING WITH:
---	---

PROJECT LOCATION URL: <https://maps.app.goo.gl/1fLLjtD67fomtDin8>
 PROJECT LIMITS: AUBURNDALE TO HAINES CITY
 EXCEPTIONS: NONE
 BRIDGE LIMITS: NONE
 RAILROAD CROSSING: CSX CROSSING 623063B

APPROVED BY:

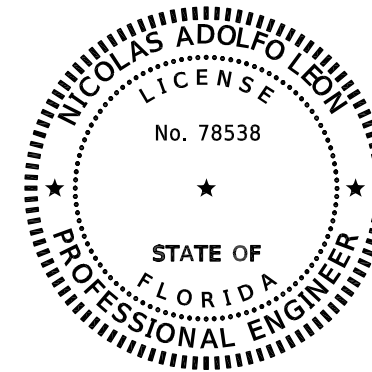

THIS ITEM HAS BEEN DIGITALLY
SIGNED AND SEALED BY

ON THE DATE ADJACENT TO THE SEAL

PRINTED COPIES OF THIS DOCUMENT ARE
NOT CONSIDERED SIGNED AND SEALED
AND THE SIGNATURE MUST BE VERIFIED
ON ANY ELECTRONIC COPIES.

HNTB CORPORATION
ONE TAMPA CITY CENTER
201 N FRANKLIN ST. SUITE 1200
TAMPA, FL. 33602
NICOLAS LEON, P.E. 78538

THE ABOVE NAMED PROFESSIONAL ENGINEER SHALL BE RESPONSIBLE FOR THE
FOLLOWING SHEETS IN ACCORDANCE WITH RULE 61G15-23.004, F.A.C.

INDEX OF SHEETS

SHEET NO	SHEET DESCRIPTION
1	COVER SHEET
2	TYPICAL SECTION NO.1
3	TYPICAL SECTION NO.2
4	TYPICAL SECTION NO.3
5	TYPICAL SECTION NO.4
6	TYPICAL SECTION NO.5
7	TYPICAL SECTION NO.6
8	TYPICAL SECTION NO.7
9	TYPICAL SECTION NO.8
10	TYPICAL SECTION NO.9
11	TYPICAL SECTION NO.10
12	TYPICAL SECTION NO.11
13	TYPICAL SECTION NO.12
14	TYPICAL SECTION NO.13
15	TYPICAL SECTION NO.14

PROJECT CONTROLS

CONTEXT CLASSIFICATION

- () C1 : NATURAL () C3C : SUBURBAN COMM.
- () C2 : RURAL () C4 : URBAN GENERAL
- () C2T : RURAL TOWN () C5 : URBAN CENTER
- (X) C3R : SUBURBAN RES. () C6 : URBAN CORE
- () N/A : L.A. FACILITY

FUNCTIONAL CLASSIFICATION

- () INTERSTATE () MAJOR COLLECTOR
- () FREEWAY/EXPWY. () MINOR COLLECTOR
- () PRINCIPAL ARTERIAL (X) LOCAL
- () MINOR ARTERIAL

HIGHWAY SYSTEM

- () NATIONAL HIGHWAY SYSTEM
- () STRATEGIC INTERMODAL SYSTEM
- () STATE HIGHWAY SYSTEM
- (X) OFF-STATE HIGHWAY SYSTEM

ACCESS CLASSIFICATION

- () 1 - FREEWAY
- () 2 - RESTRICTIVE w/Service Roads
- () 3 - RESTRICTIVE w/660 ft. Connection Spacing
- () 4 - NON-RESTRICTIVE w/2640 ft. Signal Spacing
- () 5 - RESTRICTIVE w/440 ft. Connection Spacing
- () 6 - NON-RESTRICTIVE w/1320 ft. Signal Spacing
- () 7 - BOTH MEDIAN TYPES

CRITERIA

- (X) NEW CONSTRUCTION / RECONSTRUCTION
- () RESURFACING (LA FACILITIES)
- () RRR (ARTERIALS & COLLECTORS)

POTENTIAL EXCEPTIONS AND VARIATIONS RELATED TO TYPICAL SECTION:

TYPICAL SECTION No. 1

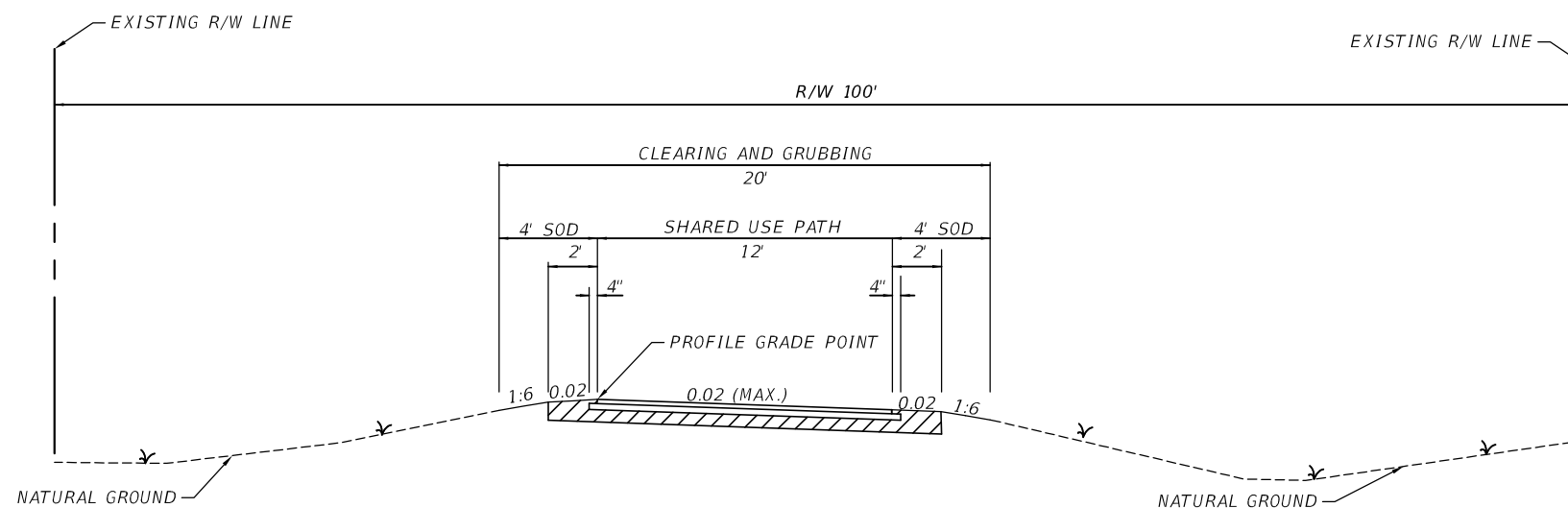

SEGMENT 1
FORMER CSX RAILROAD
BERKLEY RD. TO OLD DIXIE HWY.

TRAFFIC DATA

DESIGN SPEED = 18 MPH

FINANCIAL PROJECT ID	SHEET NO.
435391-1-22-01	2

THE OFFICIAL RECORD OF THIS SHEET IS THE ELECTRONIC FILE DIGITALLY SIGNED AND SEALED UNDER RULE 61G15-23.004, F.A.C.

PROJECT CONTROLS

CONTEXT CLASSIFICATION

- () C1 : NATURAL () C3C : SUBURBAN COMM.
- () C2 : RURAL () C4 : URBAN GENERAL
- () C2T : RURAL TOWN () C5 : URBAN CENTER
- (X) C3R : SUBURBAN RES. () C6 : URBAN CORE
- () N/A : L.A. FACILITY

FUNCTIONAL CLASSIFICATION

- () INTERSTATE (X) MAJOR COLLECTOR
- () FREEWAY/EXPWY. () MINOR COLLECTOR
- () PRINCIPAL ARTERIAL () LOCAL
- () MINOR ARTERIAL

HIGHWAY SYSTEM

- () NATIONAL HIGHWAY SYSTEM
- () STRATEGIC INTERMODAL SYSTEM
- () STATE HIGHWAY SYSTEM
- (X) OFF-STATE HIGHWAY SYSTEM

ACCESS CLASSIFICATION

- () 1 - FREEWAY
- () 2 - RESTRICTIVE w/Service Roads
- () 3 - RESTRICTIVE w/660 ft. Connection Spacing
- (X) 4 - NON-RESTRICTIVE w/2640 ft. Signal Spacing
- () 5 - RESTRICTIVE w/440 ft. Connection Spacing
- () 6 - NON-RESTRICTIVE w/1320 ft. Signal Spacing
- () 7 - BOTH MEDIAN TYPES

CRITERIA

- (X) NEW CONSTRUCTION / RECONSTRUCTION
- () RESURFACING (LA FACILITIES)
- () RRR (ARTERIALS & COLLECTORS)

POTENTIAL EXCEPTIONS AND VARIATIONS RELATED TO TYPICAL SECTION:

TYPICAL SECTION No. 2

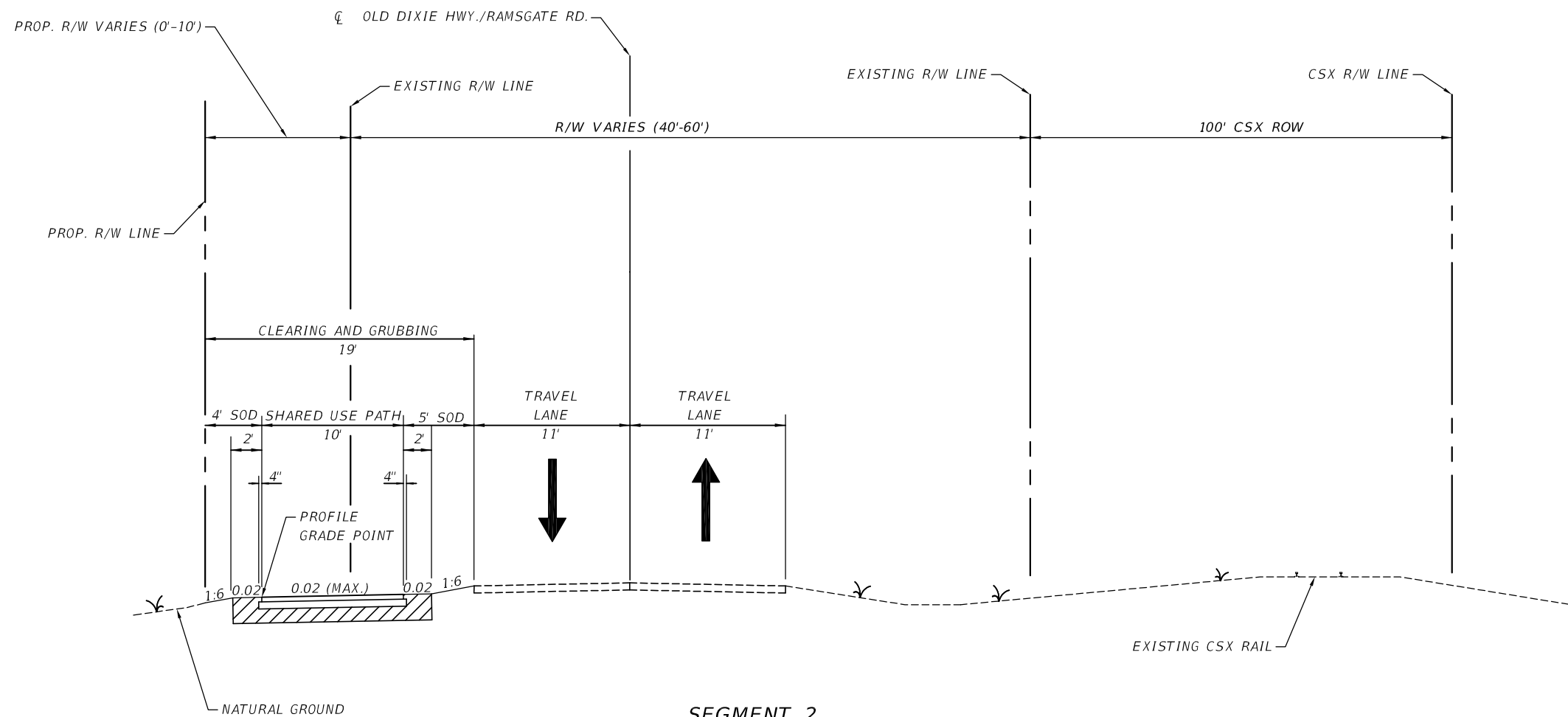

SEGMENT 2
OLD DIXIE HIGHWAY
FORMER CSX RAILROAD TO RAMSGATE RD.

RAMSGATE ROAD
OLD DIXIE HWY. TO PILAKLAKAHA AVE.

TRAFFIC DATA

CURRENT YEAR = 2019 AADT = 3800
 ESTIMATED OPENING YEAR = 2030 AADT = 5100
 ESTIMATED DESIGN YEAR = 2050 AADT = 7300
 K = 9% D = 56% T = 5% (24 HOUR)
 DESIGN HOUR T = 2.5%
 TARGET SPEED = 40 MPH
 DESIGN SPEED = 40 MPH
 POSTED SPEED = 40 MPH

FINANCIAL PROJECT ID	SHEET NO.
435391-1-22-01	3

THE OFFICIAL RECORD OF THIS SHEET IS THE ELECTRONIC FILE DIGITALLY SIGNED AND SEALED UNDER RULE 61G15-23.004, F.A.C.

PROJECT CONTROLS

CONTEXT CLASSIFICATION

- () C1 : NATURAL () C3C : SUBURBAN COMM.
- () C2 : RURAL (X) C4 : URBAN GENERAL
- () C2T : RURAL TOWN () C5 : URBAN CENTER
- () C3R : SUBURBAN RES. () C6 : URBAN CORE
- () N/A : L.A. FACILITY

FUNCTIONAL CLASSIFICATION

- () INTERSTATE (X) MAJOR COLLECTOR
- () FREEWAY/EXPWY. () MINOR COLLECTOR
- () PRINCIPAL ARTERIAL () LOCAL
- () MINOR ARTERIAL

HIGHWAY SYSTEM

- () NATIONAL HIGHWAY SYSTEM
- () STRATEGIC INTERMODAL SYSTEM
- () STATE HIGHWAY SYSTEM
- (X) OFF-STATE HIGHWAY SYSTEM

ACCESS CLASSIFICATION

- () 1 - FREEWAY
- () 2 - RESTRICTIVE w/Service Roads
- () 3 - RESTRICTIVE w/660 ft. Connection Spacing
- () 4 - NON-RESTRICTIVE w/2640 ft. Signal Spacing
- () 5 - RESTRICTIVE w/440 ft. Connection Spacing
- (X) 6 - NON-RESTRICTIVE w/1320 ft. Signal Spacing
- () 7 - BOTH MEDIAN TYPES

CRITERIA

- (X) NEW CONSTRUCTION / RECONSTRUCTION
- () RESURFACING (LA FACILITIES)
- () RRR (ARTERIALS & COLLECTORS)

POTENTIAL EXCEPTIONS AND VARIATIONS RELATED TO TYPICAL SECTION:

TYPICAL SECTION No. 3

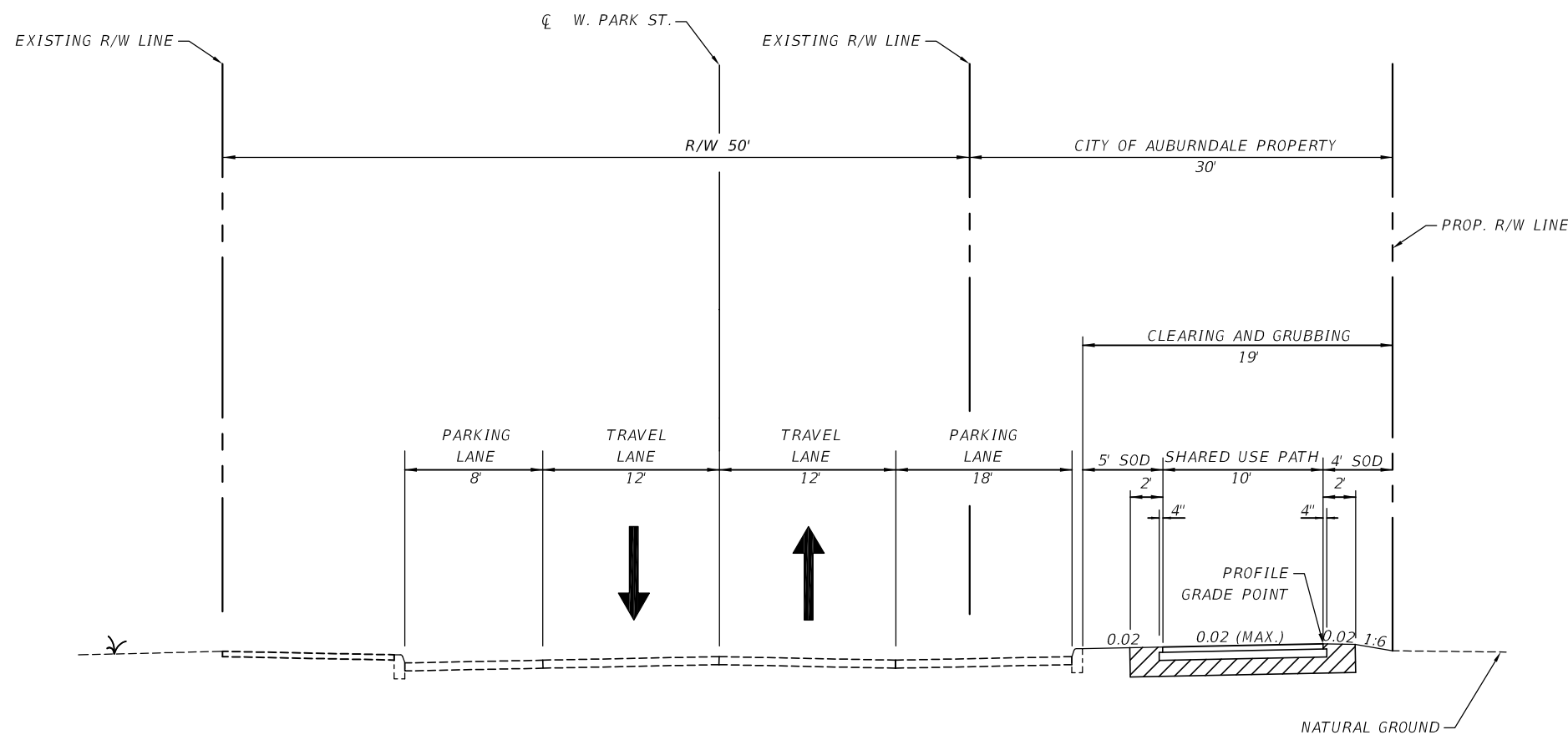

**SEGMENT 3
W. PARK STREET
PILAKLAKAHA AVE. TO MAIN ST.**

TRAFFIC DATA

CURRENT YEAR = 2019 AADT = 3700
 ESTIMATED OPENING YEAR = 2030 AADT = 5100
 ESTIMATED DESIGN YEAR = 2050 AADT = 7400
 K = 9% D = 56% T = 5.3% (24 HOUR)
 DESIGN HOUR T = 2.7%
 TARGET SPEED = 25 MPH
 DESIGN SPEED = 25 MPH
 POSTED SPEED = 25 MPH

FINANCIAL PROJECT ID	SHEET NO.
435391-1-22-01	4

THE OFFICIAL RECORD OF THIS SHEET IS THE ELECTRONIC FILE DIGITALLY SIGNED AND SEALED UNDER RULE 61G15-23.004, F.A.C.

PROJECT CONTROLS

CONTEXT CLASSIFICATION

- () C1 : NATURAL () C3C : SUBURBAN COMM.
- () C2 : RURAL () C4 : URBAN GENERAL
- (X) C2T : RURAL TOWN () C5 : URBAN CENTER
- () C3R : SUBURBAN RES. () C6 : URBAN CORE
- () N/A : L.A. FACILITY

FUNCTIONAL CLASSIFICATION

- () INTERSTATE (X) MAJOR COLLECTOR
- () FREEWAY/EXPWY. () MINOR COLLECTOR
- () PRINCIPAL ARTERIAL () LOCAL
- () MINOR ARTERIAL

HIGHWAY SYSTEM

- () NATIONAL HIGHWAY SYSTEM
- () STRATEGIC INTERMODAL SYSTEM
- () STATE HIGHWAY SYSTEM
- (X) OFF-STATE HIGHWAY SYSTEM

ACCESS CLASSIFICATION

- () 1 - FREEWAY
- () 2 - RESTRICTIVE w/Service Roads
- () 3 - RESTRICTIVE w/660 ft. Connection Spacing
- (X) 4 - NON-RESTRICTIVE w/2640 ft. Signal Spacing
- () 5 - RESTRICTIVE w/440 ft. Connection Spacing
- () 6 - NON-RESTRICTIVE w/1320 ft. Signal Spacing
- () 7 - BOTH MEDIAN TYPES

CRITERIA

- (X) NEW CONSTRUCTION / RECONSTRUCTION
- () RESURFACING (LA FACILITIES)
- () RRR (ARTERIALS & COLLECTORS)

POTENTIAL EXCEPTIONS AND VARIATIONS RELATED TO TYPICAL SECTION:

TYPICAL SECTION No. 4

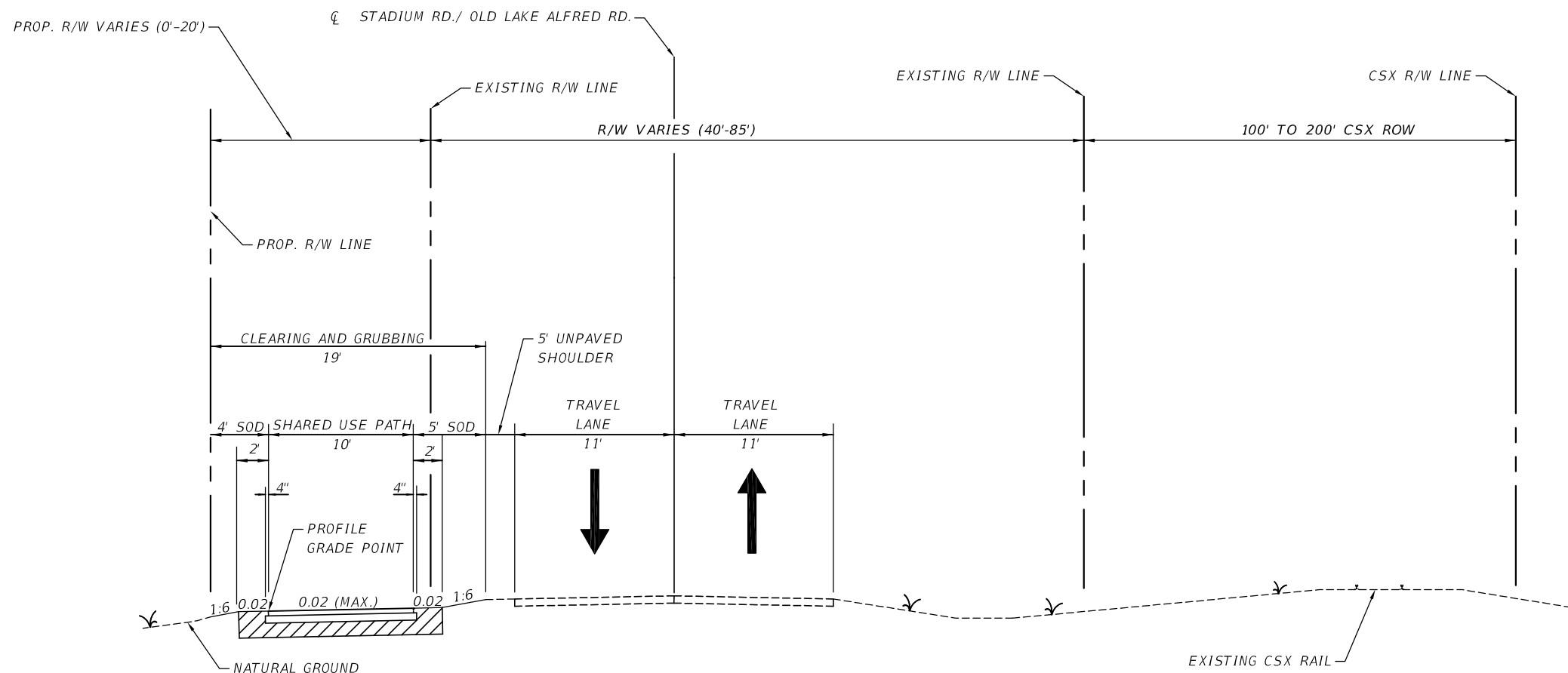

**SEGMENT 3
STADIUM ROAD
MAIN ST. TO OHIO ST.**

**SEGMENT 4
STADIUM ROAD/OLD LAKE ALFRED ROAD
OHIO ST. TO SOUTH OF CSX CROSSING**

SEGMENT 3 TRAFFIC DATA

CURRENT YEAR = 2019 AADT = 3200
 ESTIMATED OPENING YEAR = 2030 AADT = 4300
 ESTIMATED DESIGN YEAR = 2050 AADT = 6200
 K = 9% D = 56% T = 13.3% (24 HOUR)
 DESIGN HOUR T = 6.7%
 TARGET SPEED = 45 MPH
 DESIGN SPEED = 45 MPH
 POSTED SPEED = 45 MPH

SEGMENT 4 TRAFFIC DATA

CURRENT YEAR = 2019 AADT = 4600
 ESTIMATED OPENING YEAR = 2030 AADT = 6100
 ESTIMATED DESIGN YEAR = 2050 AADT = 8900
 K = 9% D = 56% T = 13.3% (24 HOUR)
 DESIGN HOUR T = 6.7%
 TARGET SPEED = 45 MPH
 DESIGN SPEED = 45 MPH
 POSTED SPEED = 45 MPH

FINANCIAL PROJECT ID	SHEET NO.
435391-1-22-01	5

THE OFFICIAL RECORD OF THIS SHEET IS THE ELECTRONIC FILE DIGITALLY SIGNED AND SEALED UNDER RULE 61G15-23.004, F.A.C.

PROJECT CONTROLS

CONTEXT CLASSIFICATION

- () C1 : NATURAL () C3C : SUBURBAN COMM.
- () C2 : RURAL () C4 : URBAN GENERAL
- () C2T : RURAL TOWN () C5 : URBAN CENTER
- (X) C3R : SUBURBAN RES. () C6 : URBAN CORE
- () N/A : L.A. FACILITY

FUNCTIONAL CLASSIFICATION

- () INTERSTATE (X) MAJOR COLLECTOR
- () FREEWAY/EXPWY. () MINOR COLLECTOR
- () PRINCIPAL ARTERIAL () LOCAL
- () MINOR ARTERIAL

HIGHWAY SYSTEM

- () NATIONAL HIGHWAY SYSTEM
- () STRATEGIC INTERMODAL SYSTEM
- () STATE HIGHWAY SYSTEM
- (X) OFF-STATE HIGHWAY SYSTEM

ACCESS CLASSIFICATION

- () 1 - FREEWAY
- () 2 - RESTRICTIVE w/Service Roads
- () 3 - RESTRICTIVE w/660 ft. Connection Spacing
- (X) 4 - NON-RESTRICTIVE w/2640 ft. Signal Spacing
- () 5 - RESTRICTIVE w/440 ft. Connection Spacing
- () 6 - NON-RESTRICTIVE w/1320 ft. Signal Spacing
- () 7 - BOTH MEDIAN TYPES

CRITERIA

- (X) NEW CONSTRUCTION / RECONSTRUCTION
- () RESURFACING (LA FACILITIES)
- () RRR (ARTERIALS & COLLECTORS)

POTENTIAL EXCEPTIONS AND VARIATIONS RELATED TO TYPICAL SECTION:

TYPICAL SECTION No. 5

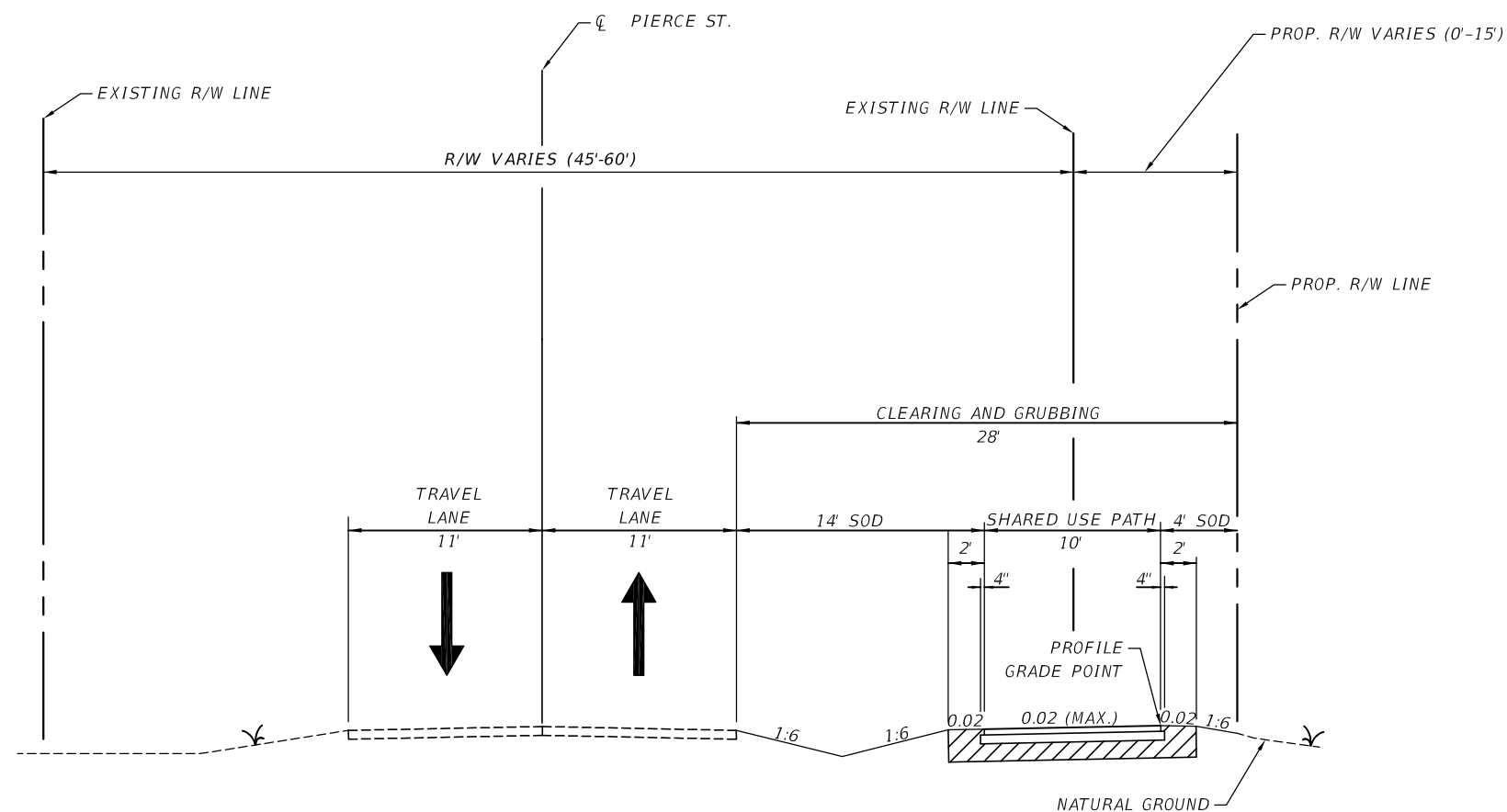

**SEGMENT 5
PIERCE STREET
SOUTH OF CSX CROSSING TO SHINN BLVD.**

TRAFFIC DATA

CURRENT YEAR = 2019 AADT = 3700
 ESTIMATED OPENING YEAR = 2030 AADT = 5100
 ESTIMATED DESIGN YEAR = 2050 AADT = 7400
 K = 9% D = 56% T = 13.3% (24 HOUR)
 DESIGN HOUR T = 6.7%
 TARGET SPEED = 30 MPH
 DESIGN SPEED = 30 MPH
 POSTED SPEED = 30 MPH

FINANCIAL PROJECT ID	SHEET NO.
435391-1-22-01	6

THE OFFICIAL RECORD OF THIS SHEET IS THE ELECTRONIC FILE DIGITALLY SIGNED AND SEALED UNDER RULE 61G15-23.004, F.A.C.

PROJECT CONTROLS

CONTEXT CLASSIFICATION

- () C1 : NATURAL (X) C3C : SUBURBAN COMM.
- () C2 : RURAL () C4 : URBAN GENERAL
- () C2T : RURAL TOWN () C5 : URBAN CENTER
- () C3R : SUBURBAN RES. () C6 : URBAN CORE
- () N/A : L.A. FACILITY

FUNCTIONAL CLASSIFICATION

- () INTERSTATE () MAJOR COLLECTOR
- () FREEWAY/EXPWY. () MINOR COLLECTOR
- (X) PRINCIPAL ARTERIAL () LOCAL
- () MINOR ARTERIAL

HIGHWAY SYSTEM

- (X) NATIONAL HIGHWAY SYSTEM
- () STRATEGIC INTERMODAL SYSTEM
- (X) STATE HIGHWAY SYSTEM
- () OFF-STATE HIGHWAY SYSTEM

ACCESS CLASSIFICATION

- () 1 - FREEWAY
- () 2 - RESTRICTIVE w/Service Roads
- () 3 - RESTRICTIVE w/660 ft. Connection Spacing
- () 4 - NON-RESTRICTIVE w/2640 ft. Signal Spacing
- (X) 5 - RESTRICTIVE w/440 ft. Connection Spacing
- () 6 - NON-RESTRICTIVE w/1320 ft. Signal Spacing
- () 7 - BOTH MEDIAN TYPES

CRITERIA

- (X) NEW CONSTRUCTION / RECONSTRUCTION
- () RESURFACING (LA FACILITIES)
- () RRR (ARTERIALS & COLLECTORS)

POTENTIAL EXCEPTIONS AND VARIATIONS RELATED TO TYPICAL SECTION:

TYPICAL SECTION No. 6

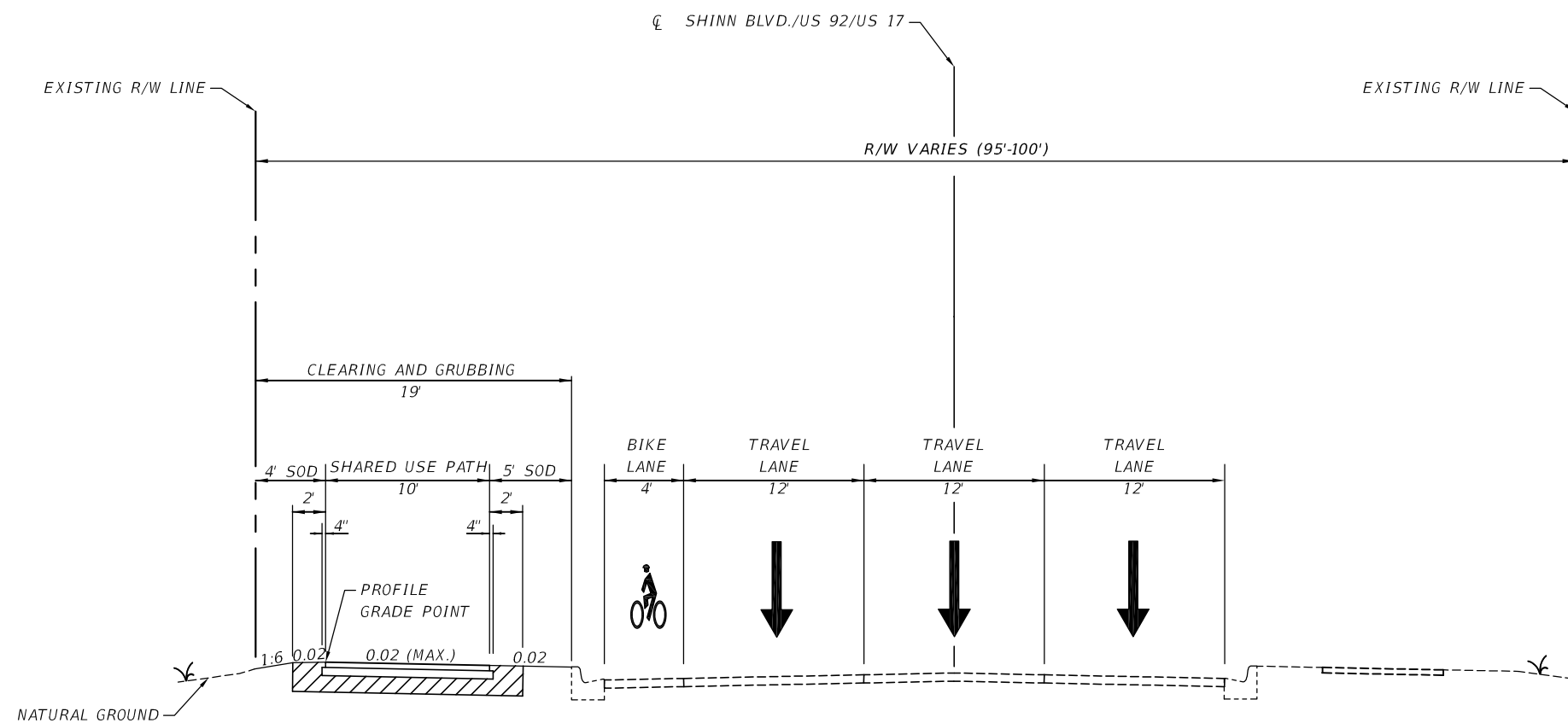

**SEGMENT 6
SHINN BOULEVARD/US 92/US 17
W. HAINES BLVD. TO POMELO ST.**

TRAFFIC DATA

CURRENT YEAR = 2019 AADT = 18500
 ESTIMATED OPENING YEAR = 2030 AADT = 24600
 ESTIMATED DESIGN YEAR = 2050 AADT = 35700
 K = 9% D = 100% T = 8.8% (24 HOUR)
 DESIGN HOUR T = 4.4%
 TARGET SPEED = 35 MPH
 DESIGN SPEED = 35 MPH
 POSTED SPEED = 35 MPH

FINANCIAL PROJECT ID	SHEET NO.
435391-1-22-01	7

THE OFFICIAL RECORD OF THIS SHEET IS THE ELECTRONIC FILE DIGITALLY SIGNED AND SEALED UNDER RULE 61G15-23.004, F.A.C.

PROJECT CONTROLS

CONTEXT CLASSIFICATION

- () C1 : NATURAL (X) C3C : SUBURBAN COMM.
- () C2 : RURAL () C4 : URBAN GENERAL
- () C2T : RURAL TOWN () C5 : URBAN CENTER
- () C3R : SUBURBAN RES. () C6 : URBAN CORE
- () N/A : L.A. FACILITY

FUNCTIONAL CLASSIFICATION

- () INTERSTATE (X) MAJOR COLLECTOR
- () FREEWAY/EXPWY. () MINOR COLLECTOR
- () PRINCIPAL ARTERIAL () LOCAL
- () MINOR ARTERIAL

HIGHWAY SYSTEM

- () NATIONAL HIGHWAY SYSTEM
- () STRATEGIC INTERMODAL SYSTEM
- () STATE HIGHWAY SYSTEM
- (X) OFF-STATE HIGHWAY SYSTEM

ACCESS CLASSIFICATION

- () 1 - FREEWAY
- () 2 - RESTRICTIVE w/Service Roads
- () 3 - RESTRICTIVE w/660 ft. Connection Spacing
- () 4 - NON-RESTRICTIVE w/2640 ft. Signal Spacing
- () 5 - RESTRICTIVE w/440 ft. Connection Spacing
- (X) 6 - NON-RESTRICTIVE w/1320 ft. Signal Spacing
- () 7 - BOTH MEDIAN TYPES

CRITERIA

- (X) NEW CONSTRUCTION / RECONSTRUCTION
- () RESURFACING (LA FACILITIES)
- () RRR (ARTERIALS & COLLECTORS)

POTENTIAL EXCEPTIONS AND VARIATIONS RELATED TO TYPICAL SECTION:

TYPICAL SECTION No. 7

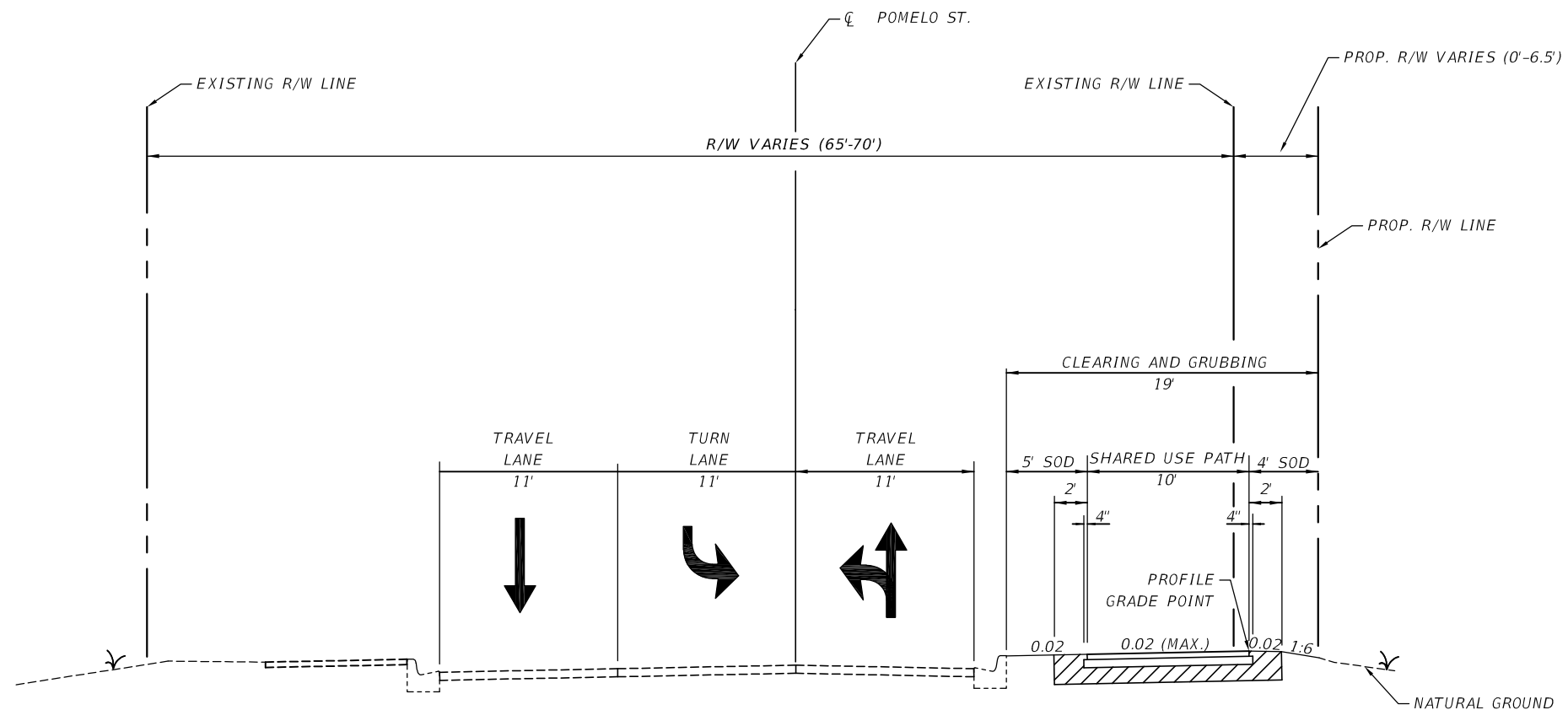

**SEGMENT 6
POMELO STREET
SHINN BLVD./US 92/US 17 TO LAKE SHORE WAY/US 92/US 17**

TRAFFIC DATA

CURRENT YEAR = 2019 AADT = 16600
 ESTIMATED OPENING YEAR = 2030 AADT = 23100
 ESTIMATED DESIGN YEAR = 2050 AADT = 33000
 K = 9% D = 56% T = 8.8% (24 HOUR)
 DESIGN HOUR T = 4.4%
 TARGET SPEED = 40 MPH
 DESIGN SPEED = 40 MPH
 POSTED SPEED = 40 MPH

FINANCIAL PROJECT ID	SHEET NO.
435391-1-22-01	8

THE OFFICIAL RECORD OF THIS SHEET IS THE ELECTRONIC FILE DIGITALLY SIGNED AND SEALED UNDER RULE 61G15-23.004, F.A.C.

PROJECT CONTROLS

CONTEXT CLASSIFICATION

- () C1 : NATURAL (X) C3C : SUBURBAN COMM.
- () C2 : RURAL () C4 : URBAN GENERAL
- () C2T : RURAL TOWN () C5 : URBAN CENTER
- () C3R : SUBURBAN RES. () C6 : URBAN CORE
- () N/A : L.A. FACILITY

FUNCTIONAL CLASSIFICATION

- () INTERSTATE () MAJOR COLLECTOR
- () FREEWAY/EXPWY. () MINOR COLLECTOR
- (X) PRINCIPAL ARTERIAL () LOCAL
- () MINOR ARTERIAL

HIGHWAY SYSTEM

- (X) NATIONAL HIGHWAY SYSTEM
- () STRATEGIC INTERMODAL SYSTEM
- (X) STATE HIGHWAY SYSTEM
- () OFF-STATE HIGHWAY SYSTEM

ACCESS CLASSIFICATION

- () 1 - FREEWAY
- () 2 - RESTRICTIVE w/Service Roads
- () 3 - RESTRICTIVE w/660 ft. Connection Spacing
- () 4 - NON-RESTRICTIVE w/2640 ft. Signal Spacing
- (X) 5 - RESTRICTIVE w/440 ft. Connection Spacing
- () 6 - NON-RESTRICTIVE w/1320 ft. Signal Spacing
- () 7 - BOTH MEDIAN TYPES

CRITERIA

- (X) NEW CONSTRUCTION / RECONSTRUCTION
- () RESURFACING (LA FACILITIES)
- () RRR (ARTERIALS & COLLECTORS)

POTENTIAL EXCEPTIONS AND VARIATIONS RELATED TO TYPICAL SECTION:

TYPICAL SECTION No. 8

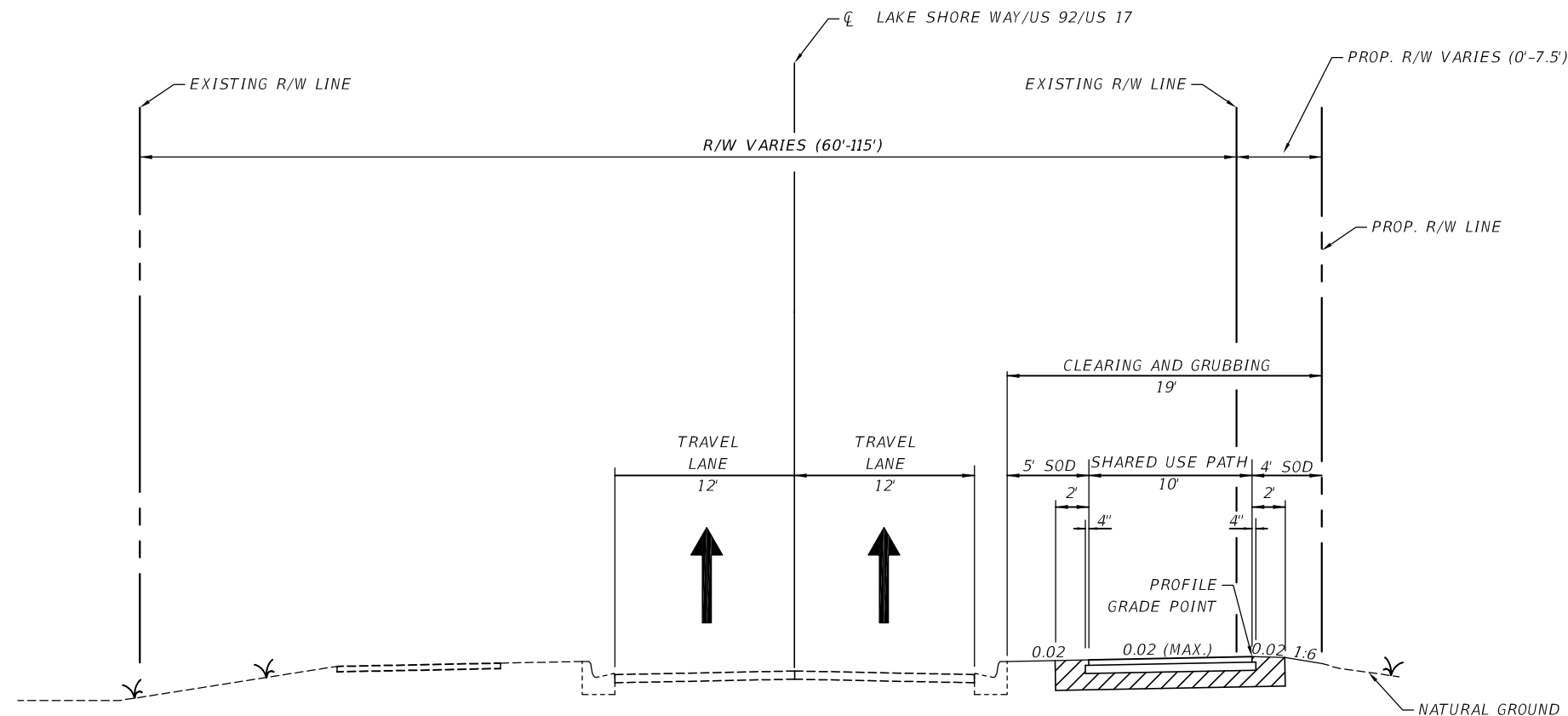

**SEGMENT 6
LAKE SHORE WAY/US 92/US 17
POMELO ST. TO N. ROCHELLE AVE.**

TRAFFIC DATA

CURRENT YEAR = 2019 AADT = 11000
 ESTIMATED OPENING YEAR = 2030 AADT = 14600
 ESTIMATED DESIGN YEAR = 2050 AADT = 21200
 K = 9% D = 100% T = 8.3% (24 HOUR)
 DESIGN HOUR T = 4.2%
 TARGET SPEED = 35 MPH
 DESIGN SPEED = 35 MPH
 POSTED SPEED = 35 MPH

FINANCIAL PROJECT ID	SHEET NO.
435391-1-22-01	9

THE OFFICIAL RECORD OF THIS SHEET IS THE ELECTRONIC FILE DIGITALLY SIGNED AND SEALED UNDER RULE 61G15-23.004, F.A.C.

PROJECT CONTROLS

CONTEXT CLASSIFICATION

- () C1 : NATURAL (X) C3C : SUBURBAN COMM.
- (X) C2 : RURAL () C4 : URBAN GENERAL
- (X) C2T : RURAL TOWN () C5 : URBAN CENTER
- (X) C3R : SUBURBAN RES. () C6 : URBAN CORE
- () N/A : L.A. FACILITY

FUNCTIONAL CLASSIFICATION

- () INTERSTATE () MAJOR COLLECTOR
- () FREEWAY/EXPWY. () MINOR COLLECTOR
- (X) PRINCIPAL ARTERIAL () LOCAL
- () MINOR ARTERIAL

HIGHWAY SYSTEM

- (X) NATIONAL HIGHWAY SYSTEM
- () STRATEGIC INTERMODAL SYSTEM
- (X) STATE HIGHWAY SYSTEM
- () OFF-STATE HIGHWAY SYSTEM

ACCESS CLASSIFICATION

- () 1 - FREEWAY
- () 2 - RESTRICTIVE w/Service Roads
- (X) 3 - RESTRICTIVE w/660 ft. Connection Spacing
- () 4 - NON-RESTRICTIVE w/2640 ft. Signal Spacing
- () 5 - RESTRICTIVE w/440 ft. Connection Spacing
- () 6 - NON-RESTRICTIVE w/1320 ft. Signal Spacing
- () 7 - BOTH MEDIAN TYPES

CRITERIA

- (X) NEW CONSTRUCTION / RECONSTRUCTION
- () RESURFACING (LA FACILITIES)
- () RRR (ARTERIALS & COLLECTORS)

POTENTIAL EXCEPTIONS AND VARIATIONS RELATED TO TYPICAL SECTION:

TYPICAL SECTION No. 9

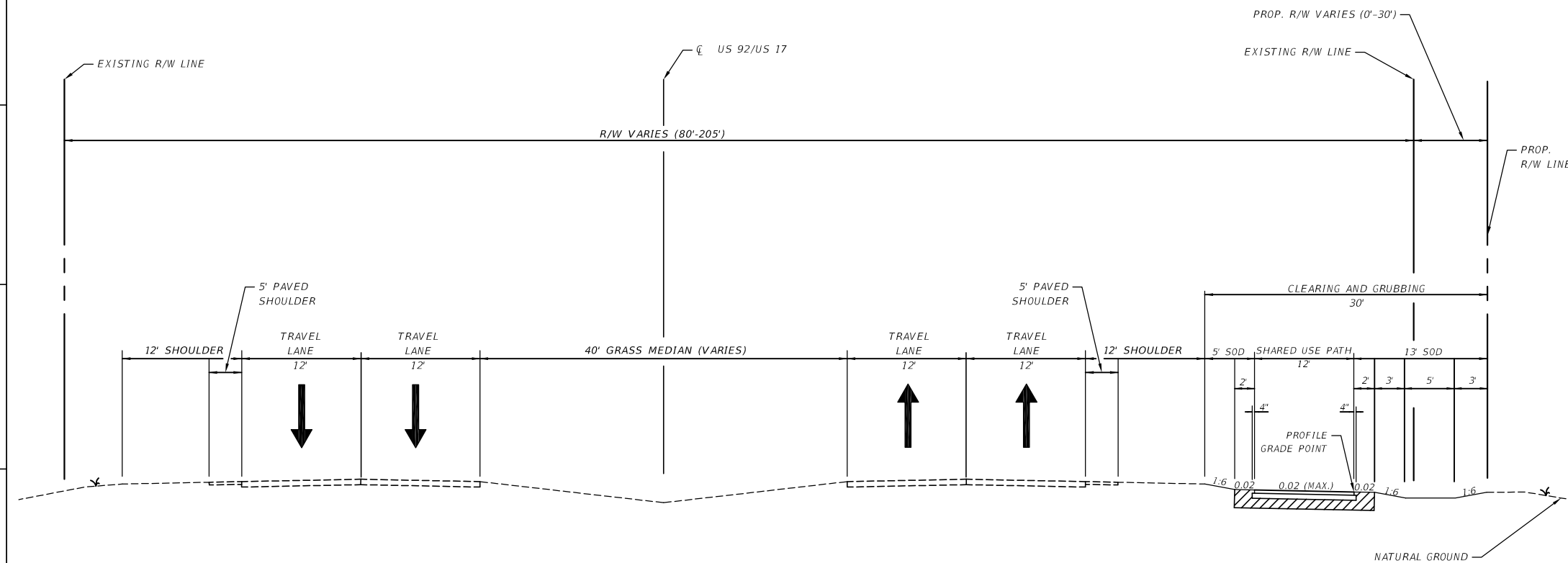

SEGMENT 7 TRAFFIC DATA

CURRENT YEAR = 2019 AADT = 21500
 ESTIMATED OPENING YEAR = 2030 AADT = 28600
 ESTIMATED DESIGN YEAR = 2050 AADT = 41500
 K = 9% D = 56% T = 8% (24 HOUR)
 DESIGN HOUR T = 4.0%
 TARGET SPEED = 60 MPH
 DESIGN SPEED = 60 MPH
 POSTED SPEED = 35-60 MPH

SEGMENT 7
US 92/US 17
N. ROCHELLE AVE. TO CENTURY DR.

SEGMENT 8 TRAFFIC DATA

CURRENT YEAR = 2019 AADT = 28500
 ESTIMATED OPENING YEAR = 2030 AADT = 37900
 ESTIMATED DESIGN YEAR = 2050 AADT = 55000
 K = 9% D = 56% T = 8.5% (24 HOUR)
 DESIGN HOUR T = 4.3%
 TARGET SPEED = 60 MPH
 DESIGN SPEED = 60 MPH
 POSTED SPEED = 45-60 MPH

SEGMENT 8
US 92/US 17
CENTURY DR. TO W. OF C ST.

CONTEXT CLASSIFICATION NOTES:
 C3C FROM N. ROCHELLE AVE. TO CENTURY DR.
 C2 FROM CENTURY DR. TO FLETCHER FISH CAMP RD.
 C3C FROM FLETCHER FISH CAMP RD. TO DYSON RD.
 C3R FROM DYSON RD. TO US 27
 C2T FROM US 27 TO W. OF C ST.

FINANCIAL PROJECT ID	SHEET NO.
435391-1-22-01	10

THE OFFICIAL RECORD OF THIS SHEET IS THE ELECTRONIC FILE DIGITALLY SIGNED AND SEALED UNDER RULE 61G15-23.004, F.A.C.

PROJECT CONTROLS

CONTEXT CLASSIFICATION

- () C1 : NATURAL () C3C : SUBURBAN COMM.
- () C2 : RURAL (X) C4 : URBAN GENERAL
- (X) C2T : RURAL TOWN () C5 : URBAN CENTER
- () C3R : SUBURBAN RES. () C6 : URBAN CORE
- () N/A : L.A. FACILITY

FUNCTIONAL CLASSIFICATION

- () INTERSTATE () MAJOR COLLECTOR
- () FREEWAY/EXPWY. () MINOR COLLECTOR
- (X) PRINCIPAL ARTERIAL () LOCAL
- () MINOR ARTERIAL

HIGHWAY SYSTEM

- (X) NATIONAL HIGHWAY SYSTEM
- () STRATEGIC INTERMODAL SYSTEM
- (X) STATE HIGHWAY SYSTEM
- () OFF-STATE HIGHWAY SYSTEM

ACCESS CLASSIFICATION

- () 1 - FREEWAY
- () 2 - RESTRICTIVE w/Service Roads
- () 3 - RESTRICTIVE w/660 ft. Connection Spacing
- () 4 - NON-RESTRICTIVE w/2640 ft. Signal Spacing
- (X) 5 - RESTRICTIVE w/440 ft. Connection Spacing
- () 6 - NON-RESTRICTIVE w/1320 ft. Signal Spacing
- () 7 - BOTH MEDIAN TYPES

CRITERIA

- (X) NEW CONSTRUCTION / RECONSTRUCTION
- () RESURFACING (LA FACILITIES)
- () RRR (ARTERIALS & COLLECTORS)

POTENTIAL EXCEPTIONS AND VARIATIONS RELATED TO TYPICAL SECTION:

TYPICAL SECTION No. 10

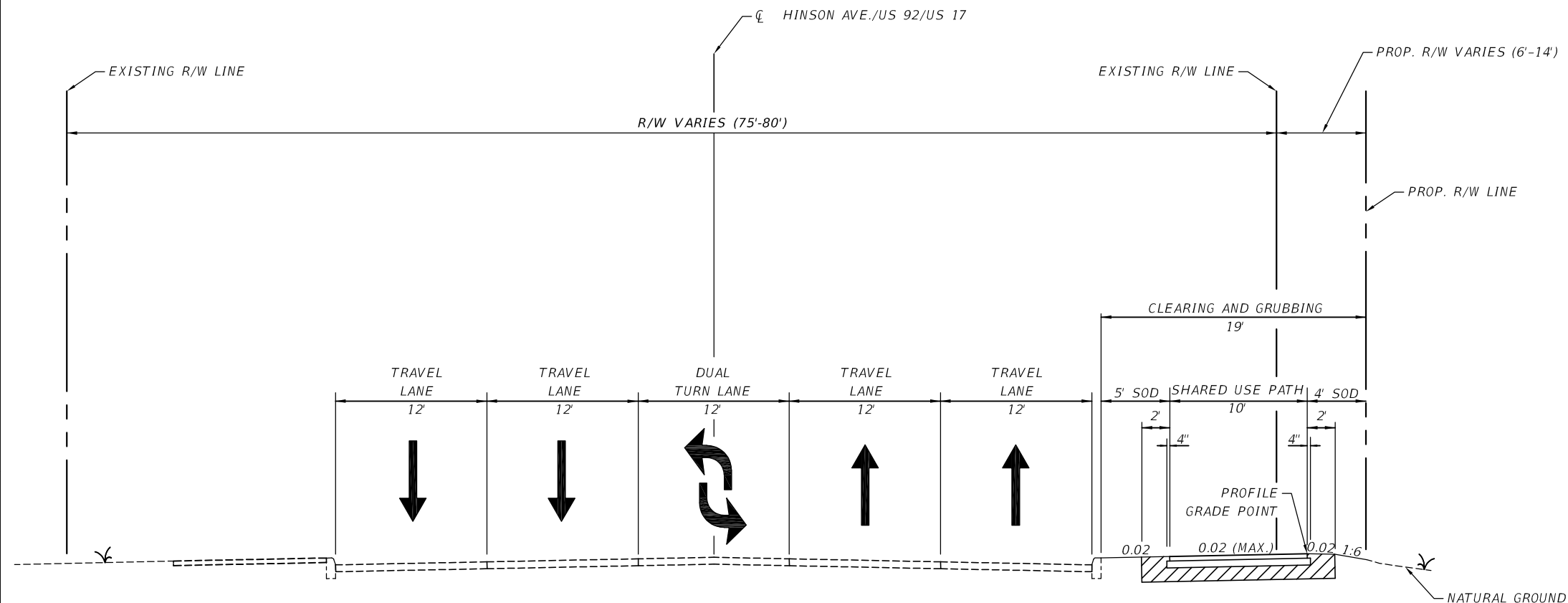

**SEGMENT 9
HINSON AVENUE/US 17/US 92
W. OF C ST. TO N. 6TH ST.**

TRAFFIC DATA

CURRENT YEAR = 2019 AADT = 26500
 ESTIMATED OPENING YEAR = 2030 AADT = 35200
 ESTIMATED DESIGN YEAR = 2050 AADT = 51100
 K = 9% D = 56% T = 5.1% (24 HOUR)
 DESIGN HOUR T = 2.6%
 TARGET SPEED = 45 MPH
 DESIGN SPEED = 45 MPH
 POSTED SPEED = 30-45 MPH

CONTEXT CLASSIFICATION NOTES:
 C2T FROM W. OF C ST. TO S. 1ST ST.
 C4 FROM S. 1ST ST. TO N. 6TH ST.

FINANCIAL PROJECT ID	SHEET NO.
435391-1-22-01	11

THE OFFICIAL RECORD OF THIS SHEET IS THE ELECTRONIC FILE DIGITALLY SIGNED AND SEALED UNDER RULE 61G15-23.004, F.A.C.

PROJECT CONTROLS

CONTEXT CLASSIFICATION

- C1 : NATURAL C3C : SUBURBAN COMM.
- C2 : RURAL C4 : URBAN GENERAL
- C2T : RURAL TOWN C5 : URBAN CENTER
- C3R : SUBURBAN RES. C6 : URBAN CORE
- N/A : L.A. FACILITY

FUNCTIONAL CLASSIFICATION

- INTERSTATE MAJOR COLLECTOR
- FREEWAY/EXPWY. MINOR COLLECTOR
- PRINCIPAL ARTERIAL LOCAL
- MINOR ARTERIAL

HIGHWAY SYSTEM

- NATIONAL HIGHWAY SYSTEM
- STRATEGIC INTERMODAL SYSTEM
- STATE HIGHWAY SYSTEM
- OFF-STATE HIGHWAY SYSTEM

ACCESS CLASSIFICATION

- 1 - FREEWAY
- 2 - RESTRICTIVE w/Service Roads
- 3 - RESTRICTIVE w/660 ft. Connection Spacing
- 4 - NON-RESTRICTIVE w/2640 ft. Signal Spacing
- 5 - RESTRICTIVE w/440 ft. Connection Spacing
- 6 - NON-RESTRICTIVE w/1320 ft. Signal Spacing
- 7 - BOTH MEDIAN TYPES

CRITERIA

- NEW CONSTRUCTION / RECONSTRUCTION
- RESURFACING (LA FACILITIES)
- RRR (ARTERIALS & COLLECTORS)

POTENTIAL EXCEPTIONS AND VARIATIONS RELATED TO TYPICAL SECTION:

TYPICAL SECTION No. 11

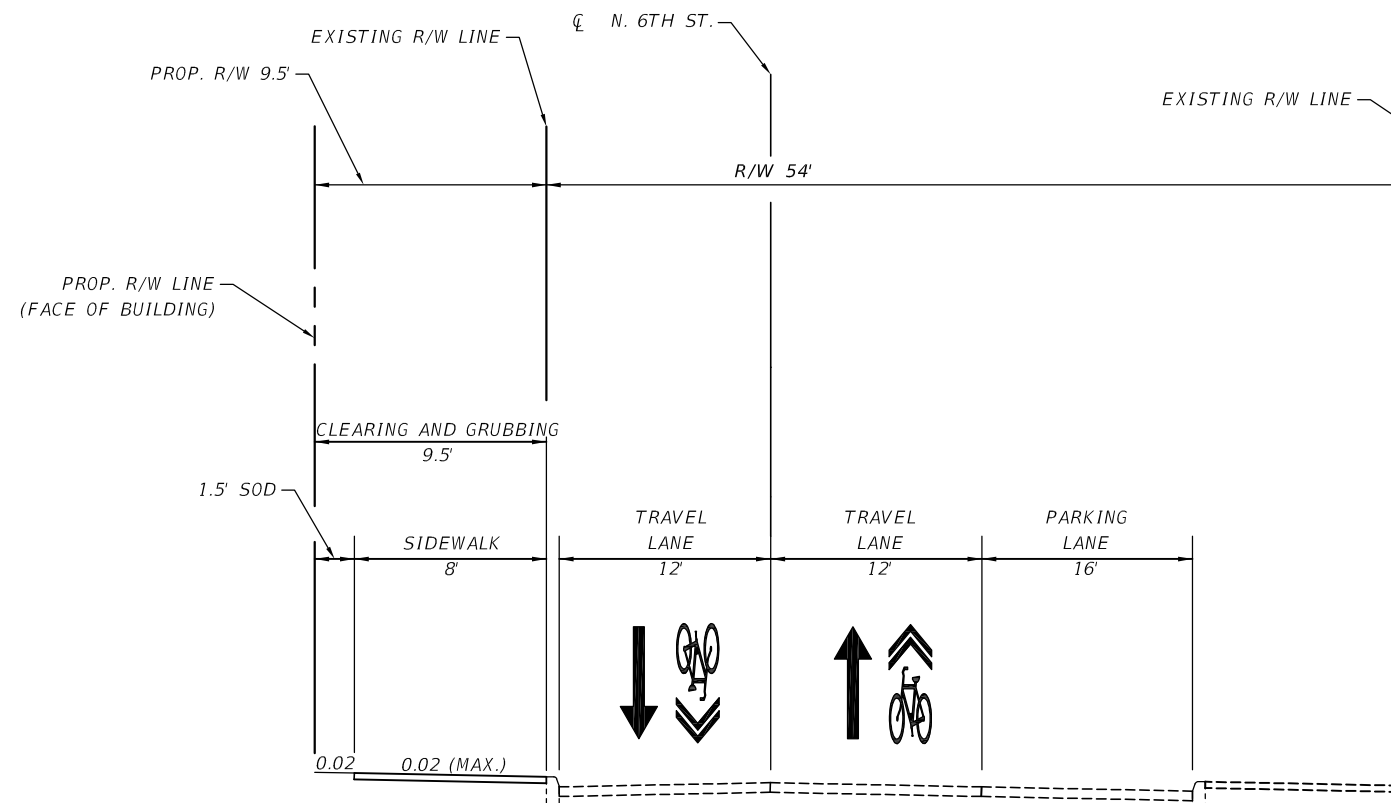

SEGMENT 10
N. 6TH ST.
E. HINSON AVE. TO COURT AVE.

TRAFFIC DATA

CURRENT YEAR = 2019 AADT = 950
 ESTIMATED OPENING YEAR = 2030 AADT = 1300
 ESTIMATED DESIGN YEAR = 2050 AADT = 1800
 K = 9% D = 56% T = 13.3% (24 HOUR)
 DESIGN HOUR T = 6.7%
 TARGET SPEED = 25 MPH
 DESIGN SPEED = 25 MPH
 POSTED SPEED = 25 MPH

TRAFFIC DATA SHOWN IS FOR N. 5TH STREET. NO DATA WAS AVAILABLE FOR N. 6TH STREET FROM E. HINSON AVENUE TO COURT AVENUE.

FINANCIAL PROJECT ID	SHEET NO.
435391-1-22-01	12

PROJECT CONTROLS

CONTEXT CLASSIFICATION

- C1 : NATURAL C3C : SUBURBAN COMM.
- C2 : RURAL C4 : URBAN GENERAL
- C2T : RURAL TOWN C5 : URBAN CENTER
- C3R : SUBURBAN RES. C6 : URBAN CORE
- N/A : L.A. FACILITY

FUNCTIONAL CLASSIFICATION

- INTERSTATE MAJOR COLLECTOR
- FREEWAY/EXPWY. MINOR COLLECTOR
- PRINCIPAL ARTERIAL LOCAL
- MINOR ARTERIAL

HIGHWAY SYSTEM

- NATIONAL HIGHWAY SYSTEM
- STRATEGIC INTERMODAL SYSTEM
- STATE HIGHWAY SYSTEM
- OFF-STATE HIGHWAY SYSTEM

ACCESS CLASSIFICATION

- 1 - FREEWAY
- 2 - RESTRICTIVE w/Service Roads
- 3 - RESTRICTIVE w/660 ft. Connection Spacing
- 4 - NON-RESTRICTIVE w/2640 ft. Signal Spacing
- 5 - RESTRICTIVE w/440 ft. Connection Spacing
- 6 - NON-RESTRICTIVE w/1320 ft. Signal Spacing
- 7 - BOTH MEDIAN TYPES

CRITERIA

- NEW CONSTRUCTION / RECONSTRUCTION
- RESURFACING (LA FACILITIES)
- RRR (ARTERIALS & COLLECTORS)

POTENTIAL EXCEPTIONS AND VARIATIONS RELATED TO TYPICAL SECTION:

TYPICAL SECTION No. 12

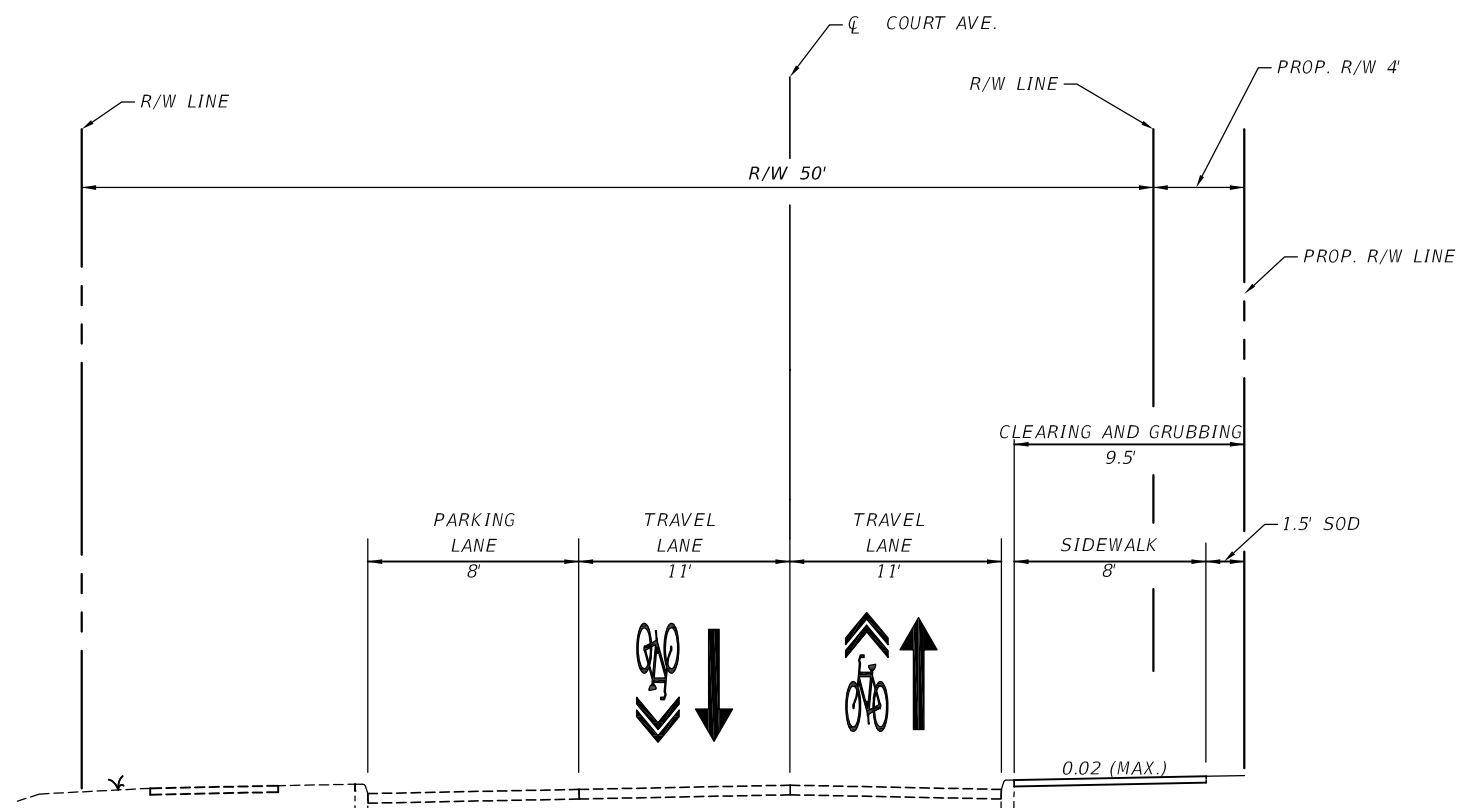

**SEGMENT 10
COURT AVENUE
N. 5TH ST. TO N 6TH ST.**

TRAFFIC DATA

CURRENT YEAR = 2019 AADT = 950
 ESTIMATED OPENING YEAR = 2030 AADT = 1300
 ESTIMATED DESIGN YEAR = 2050 AADT = 1800
 K = 9% D = 56% T = 13.3% (24 HOUR)
 DESIGN HOUR T = 6.7%
 TARGET SPEED = 25 MPH
 DESIGN SPEED = 25 MPH
 POSTED SPEED = 25 MPH

TRAFFIC DATA SHOWN IS FOR N. 5TH STREET. NO DATA WAS AVAILABLE FOR COURT AVENUE FROM N. 5TH STREET TO N. 6TH STREET.

FINANCIAL PROJECT ID	SHEET NO.
435391-1-22-01	13

PROJECT CONTROLS

CONTEXT CLASSIFICATION

- () C1 : NATURAL () C3C : SUBURBAN COMM.
- () C2 : RURAL (X) C4 : URBAN GENERAL
- () C2T : RURAL TOWN () C5 : URBAN CENTER
- () C3R : SUBURBAN RES. () C6 : URBAN CORE
- () N/A : L.A. FACILITY

FUNCTIONAL CLASSIFICATION

- () INTERSTATE () MAJOR COLLECTOR
- () FREEWAY/EXPWY. (X) MINOR COLLECTOR
- () PRINCIPAL ARTERIAL () LOCAL
- () MINOR ARTERIAL

HIGHWAY SYSTEM

- () NATIONAL HIGHWAY SYSTEM
- () STRATEGIC INTERMODAL SYSTEM
- () STATE HIGHWAY SYSTEM
- (X) OFF-STATE HIGHWAY SYSTEM

ACCESS CLASSIFICATION

- () 1 - FREEWAY
- () 2 - RESTRICTIVE w/Service Roads
- () 3 - RESTRICTIVE w/660 ft. Connection Spacing
- () 4 - NON-RESTRICTIVE w/2640 ft. Signal Spacing
- () 5 - RESTRICTIVE w/440 ft. Connection Spacing
- (X) 6 - NON-RESTRICTIVE w/1320 ft. Signal Spacing
- () 7 - BOTH MEDIAN TYPES

CRITERIA

- (X) NEW CONSTRUCTION / RECONSTRUCTION
- () RESURFACING (LA FACILITIES)
- () RRR (ARTERIALS & COLLECTORS)

POTENTIAL EXCEPTIONS AND VARIATIONS RELATED TO TYPICAL SECTION:

TYPICAL SECTION No. 13

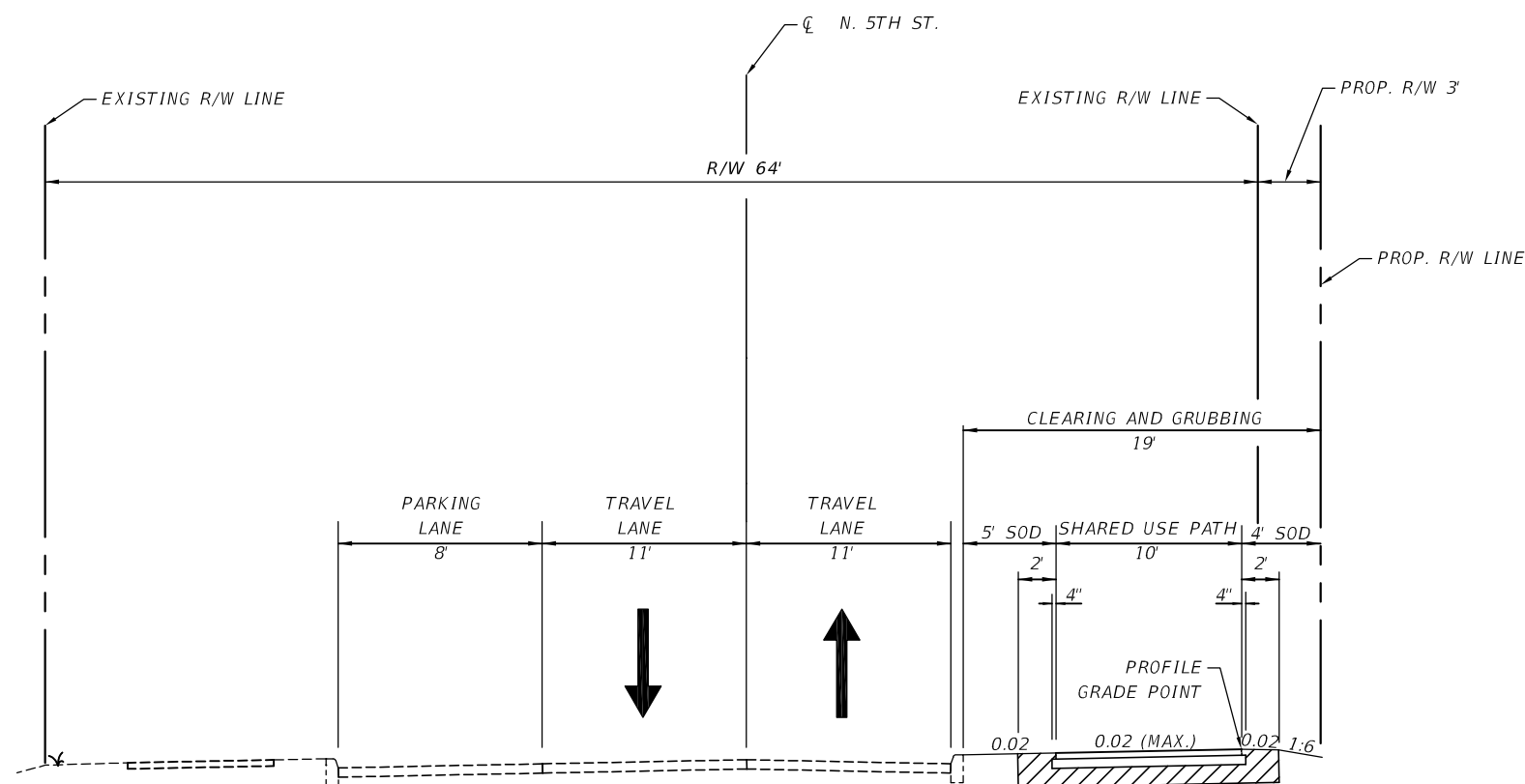

**SEGMENT 10
N. 5TH ST
COURT AVE. TO E. MAIN ST.**

TRAFFIC DATA

CURRENT YEAR = 2019 AADT = 950
 ESTIMATED OPENING YEAR = 2030 AADT = 1300
 ESTIMATED DESIGN YEAR = 2050 AADT = 1800
 K = 9% D = 56% T = 13.3% (24 HOUR)
 DESIGN HOUR T = 6.7%
 TARGET SPEED = 25 MPH
 DESIGN SPEED = 25 MPH
 POSTED SPEED = 25 MPH

THE OFFICIAL RECORD OF THIS SHEET IS THE ELECTRONIC FILE DIGITALLY SIGNED AND SEALED UNDER RULE 61G15-23.004, F.A.C.

FINANCIAL PROJECT ID	SHEET NO.
435391-1-22-01	14

PROJECT CONTROLS

CONTEXT CLASSIFICATION

- () C1 : NATURAL () C3C : SUBURBAN COMM.
- () C2 : RURAL (X) C4 : URBAN GENERAL
- () C2T : RURAL TOWN () C5 : URBAN CENTER
- () C3R : SUBURBAN RES. () C6 : URBAN CORE
- () N/A : L.A. FACILITY

FUNCTIONAL CLASSIFICATION

- () INTERSTATE () MAJOR COLLECTOR
- () FREEWAY/EXPWY. () MINOR COLLECTOR
- () PRINCIPAL ARTERIAL (X) LOCAL
- () MINOR ARTERIAL

HIGHWAY SYSTEM

- () NATIONAL HIGHWAY SYSTEM
- () STRATEGIC INTERMODAL SYSTEM
- () STATE HIGHWAY SYSTEM
- (X) OFF-STATE HIGHWAY SYSTEM

ACCESS CLASSIFICATION

- () 1 - FREEWAY
- () 2 - RESTRICTIVE w/Service Roads
- () 3 - RESTRICTIVE w/660 ft. Connection Spacing
- () 4 - NON-RESTRICTIVE w/2640 ft. Signal Spacing
- () 5 - RESTRICTIVE w/440 ft. Connection Spacing
- (X) 6 - NON-RESTRICTIVE w/1320 ft. Signal Spacing
- () 7 - BOTH MEDIAN TYPES

CRITERIA

- (X) NEW CONSTRUCTION / RECONSTRUCTION
- () RESURFACING (LA FACILITIES)
- () RRR (ARTERIALS & COLLECTORS)

POTENTIAL EXCEPTIONS AND VARIATIONS RELATED TO TYPICAL SECTION:

TYPICAL SECTION No. 14

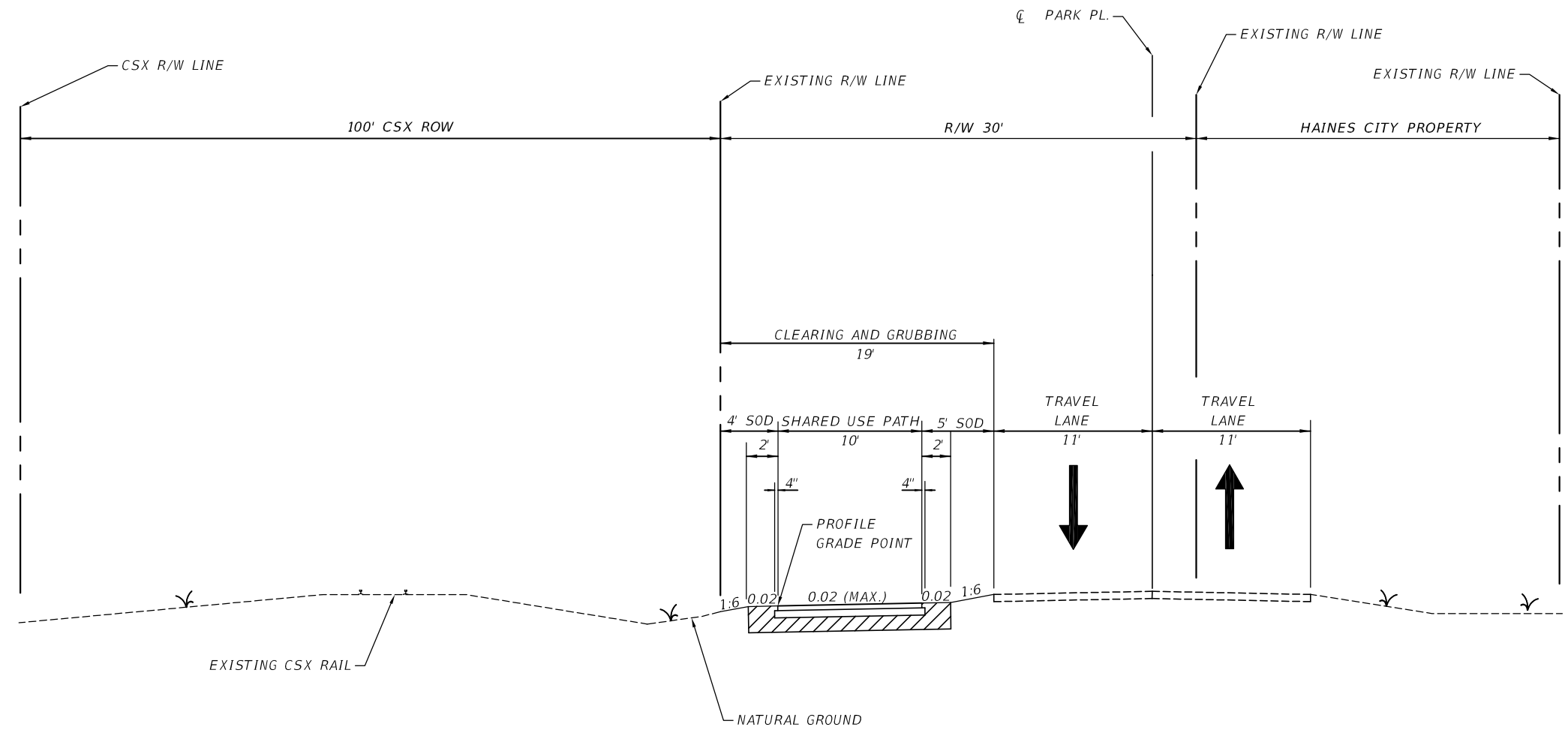

**SEGMENT 10
PARK PLACE
INGRAHAM AVE. TO LILY AVE.**

TRAFFIC DATA

CURRENT YEAR = 2019 AADT = 950
 ESTIMATED OPENING YEAR = 2030 AADT = 1300
 ESTIMATED DESIGN YEAR = 2050 AADT = 1800
 K = 9% D = 56% T = 13.3% (24 HOUR)
 DESIGN HOUR T = 6.7%
 TARGET SPEED = 25 MPH
 DESIGN SPEED = 25 MPH
 POSTED SPEED = 25 MPH

TRAFFIC DATA SHOWN IS FOR N. 5TH STREET. NO DATA WAS AVAILABLE FOR PARK PLACE FROM INGRAHAM AVENUE TO LILY AVENUE.

THE OFFICIAL RECORD OF THIS SHEET IS THE ELECTRONIC FILE DIGITALLY SIGNED AND SEALED UNDER RULE 61G15-23.004, F.A.C.

FINANCIAL PROJECT ID	SHEET NO.
435391-1-22-01	15

APPENDIX B:
FEMA FIRM

NOTES TO USERS

This map is for use in administering the National Flood Insurance Program. It does not necessarily identify all areas subject to flooding, particularly from local drainage sources of small size. The community map repository should be consulted for possible updated or additional flood hazard information.

To obtain more detailed information in areas where Base Flood Elevations (BFEs) and/or floodway depths have been determined, users are encouraged to consult the Flood Profiles and Floodway Data and/or Summary of Stillwater Elevations tables contained within the Flood Insurance Study (FIS) report that accompanies this FIRM. Users should be aware that BFEs shown on the FIRM represent rounded tenth-foot elevations. These BFEs are intended for flood insurance rating purposes only and should not be used as the sole source of flood elevation information. Accordingly, flood elevation data presented in the FIS report should be utilized in conjunction with the FIRM for purposes of construction and/or floodplain management.

Coastal Base Flood Elevations (BFEs) shown on this map apply only landward of 0.0' North American Vertical Datum of 1988 (NAVD 88). Users of this FIRM should be aware that coastal flood elevations are also provided in the Summary of Stillwater Elevations table in the Flood Insurance Study report for this jurisdiction. Elevations shown in the Summary of Stillwater Elevations table should be used for construction and/or floodplain management purposes when they are higher than the elevations shown on this FIRM.

Boundaries of the floodways were computed at cross sections and interpolated between cross sections. The floodways were based on hydraulic considerations with regard to requirements of the National Flood Insurance Program. Floodway widths and other pertinent floodway data are provided in the Flood Insurance Study report for this jurisdiction.

Certain areas not in Special Flood Hazard Areas may be protected by flood control structures. Refer to Section 2.4 "Flood Protection Measures" of the Flood Insurance Study report for information on flood control structures for this jurisdiction.

Base map information shown on this FIRM was provided in digital format by the Southwest Florida Water Management District. The original orthophotographic base imagery was provided in color with a one-foot pixel resolution at a scale of 1" = 100' from photography flown January - March 2005.

This map reflects more detailed and up-to-date stream channel configurations than those shown on the previous FIRM for this jurisdiction. The floodplains and floodways that were transferred from the previous FIRM may have been adjusted to conform to these new stream channel configurations. As a result, the Flood Profiles and Floodway Data tables in the Flood Insurance Study report (which contains authoritative hydraulic data) may reflect stream channel distances that differ from what is shown on this map.

Corporate limits shown on this map are based on the best data available at the time of publication. Because changes due to annexations or de-annexations may have occurred after this map was published, map users should contact appropriate community officials to verify current corporate limit locations.

Please refer to the separately printed Map Index for an overview map of the county showing the layout of map panels, community map repository addresses; and a Listing of Communities table containing National Flood Insurance Program dates for each community as well as a listing of the panels on which each community is located.

For information on available products associated with this FIRM visit the MapService Center (MSC) website at http://msc.fema.gov. Available products may include previously issued Letters of Map Change, a Flood Insurance Study Report, and/or digital versions of this map. Many of these products can be ordered or obtained directly from the MSC website.

If you have questions about this map, how to order products, or the National Flood Insurance Program in general, please call the FEMA Map Information Exchange (FMIX) at 1-877-FEMA-MAP (1-877-336-2627) or visit the FEMA website at http://www.fema.gov/business/infp.

DATUM INFORMATION

The projection used in the preparation of this map was State Plane Florida West. The horizontal datum was HARN, GRS1980 spheroid. Differences in datum, spheroid, projection or State Plane Zone used in the production of FIRMs for adjacent jurisdictions may result in slight positional differences in map features across jurisdiction boundaries. These differences do not reflect the accuracy of this FIRM.

Base Flood Elevation (BFEs) on this map are referenced to the North American Vertical Datum of 1988. These flood elevations must be compared to structure and ground elevations referenced to the same vertical datum. For information regarding conversion between the National Geodetic Vertical Datum of 1929 and the North American Vertical Datum of 1988, visit the National Geodetic Survey website at http://www.ngs.noaa.gov or contact the National Geodetic Survey at the following address:

NGS Information Services
National Geodetic Survey, NOAA,
NIMS12
SSMNC-2, #9202
1315 East-West Highway
Silver Spring, Maryland 20910-3282
(301) 713-3242

To obtain current elevation, description, and/or location information for benchmarks shown on this map, please contact the Information Services Branch of the National Geodetic Survey at (301) 713-3242 or visit its website at http://www.ngs.noaa.gov/.

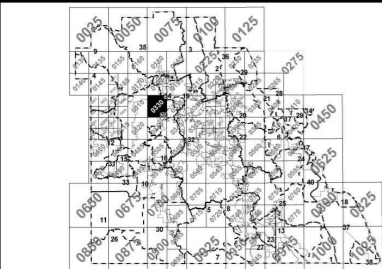

Table with 5 columns: Watershed, Datum Offset (ft), Study Type, Total Rainfall Volume (in) 1 Day, 5 Day, Multi-Day, Date of Model. Lists watersheds like Abuckee Creek, Big Creek East, etc.

* All Polk County watersheds listed.
** Multi-day event used only in specific sub-basins, refer to FIS report.



This digital Flood Insurance Rate Map (FIRM) was produced through a cooperative partnership between the Southwest Florida Water Management District (SWFWMD), the South Florida Water Management District (SFWMD), Polk County, Federal Emergency Management Agency (FEMA), and the associated communities within Polk County.

City of Auburndale 120262

LEGEND

Legend defining symbols for Special Flood Hazard Areas (Zone A, AE, AH, AO, AR, A99, V, VE), Floodway Areas, Other Flood Areas (Zone X, D), Other Areas (Zone X, D), Coastal Barrier Resources System (CBRS) Areas, and Otherwise Protected Areas (OPAs). Includes map scale and coordinate information.

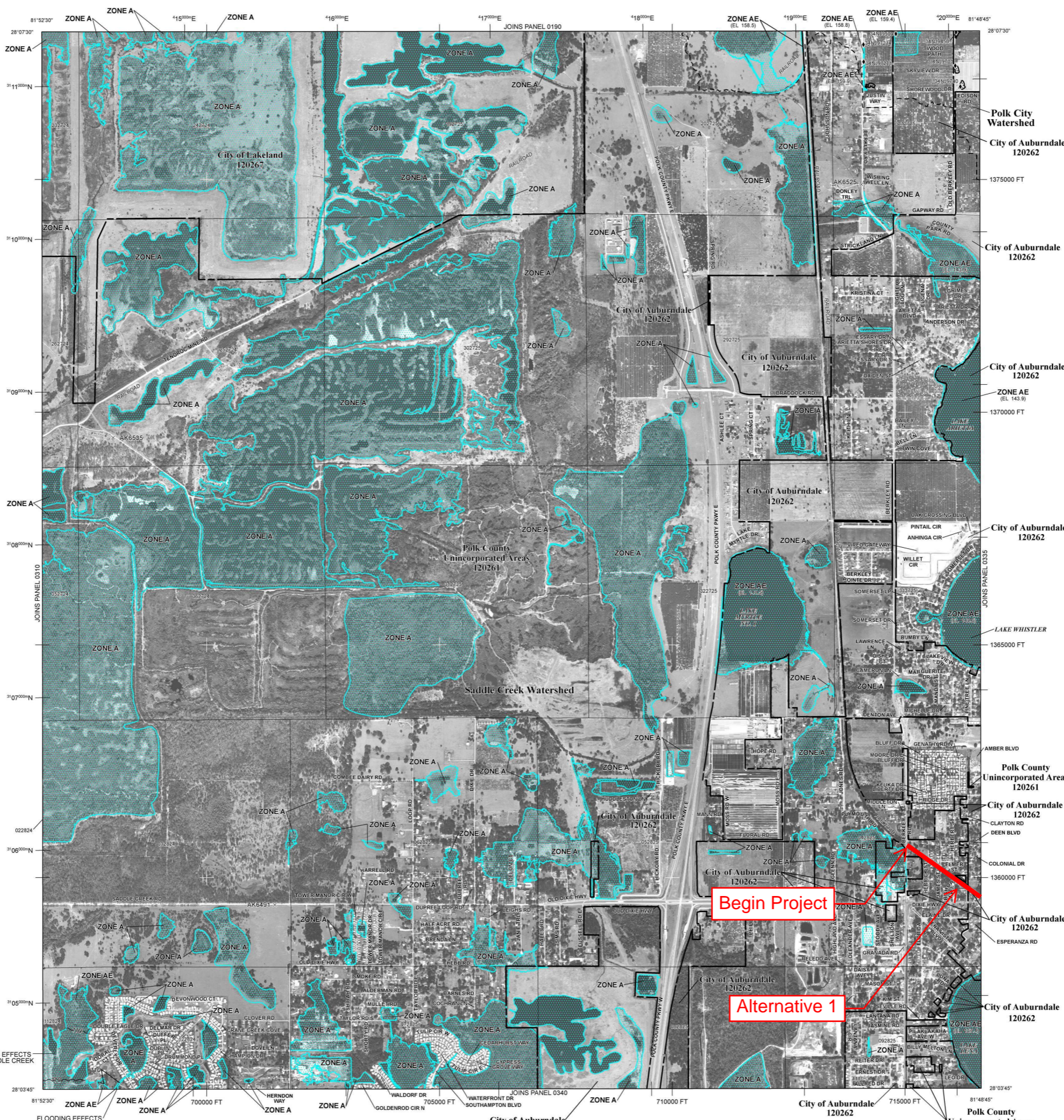

Begin Project

Alternative 1

NFIP PANEL 0330G
FIRM FLOOD INSURANCE RATE MAP
POLK COUNTY, FLORIDA AND INCORPORATED AREAS
PANEL 330 OF 1025
CONTAINS: COMMUNITY NUMBER PANEL SUFFIX
AUBURNDALE, CITY OF 120262 0330 G
LAKELAND, CITY OF 120287 0330 G
POLK COUNTY 120281 0330 G
MAP NUMBER 12105C0330G
MAP REVISED DECEMBER 22, 2016
Federal Emergency Management Agency

NOTES TO USERS

This map is for use in administering the National Flood Insurance Program. It does not necessarily identify all areas subject to flooding...

To obtain more detailed information in areas where Base Flood Elevations (BFEs) and/or floodway areas have been determined, users are encouraged to consult the Flood Profiles and Floodway Data and/or Summary of Stillwater Elevations tables...

Coastal Base Flood Elevations (BFEs) shown on this map apply only landward of 0.0' North American Vertical Datum of 1988 (NAVD 88). Users of this FIRM should be aware that coastal flood elevations are also provided in the Summary of Stillwater Elevations table...

Boundaries of the floodways were computed at cross sections and interpolated between cross sections. The floodways were based on hydraulic considerations with regard to requirements of the National Flood Insurance Program...

Certain areas not in Special Flood Hazard Areas may be protected by flood control structures. Refer to Section 2.4 "Flood Protection Measures" of the Flood Insurance Study report for information on flood control structures for this jurisdiction.

Base map information shown on this FIRM was provided in digital format by the Southwest Florida Water Management District. The original orthophotographic base imagery was provided in color with one-foot pixel resolution at a scale of 1" = 100' from photography flown January - March 2005.

This map reflects more detailed and up-to-date stream channel configurations than those shown on the previous FIRM for this jurisdiction. The floodplains and floodways that were transferred from the previous FIRM may have been adjusted to conform to these new stream channel configurations...

Corporate limits shown on this map are based on the best data available at the time of publication. Because changes due to annexations or de-annexations may have occurred after this map was published, map users should contact appropriate community officials to verify current corporate limit locations.

Please refer to the separately printed Map Index for an overview map of the county showing the layout of map panels, community map repository address, and a Listing of Communities table containing National Flood Insurance Program dates for each community as well as a listing of the panels on which each community is located.

For information on available products associated with this FIRM visit the MapService Center (MSC) website at http://msc.fema.gov. Available products may include previously issued Letters of Map Change, a Flood Insurance Study Report, and/or digital versions of this map. Many of these products can be ordered or obtained directly from the MSC website.

If you have questions about this map, how to order products, or the National Flood Insurance Program in general, please call the FEMA Map Information Exchange (FMIX) at 1-877-FEMA-MAP (1-877-336-2627) or visit the FEMA website at http://www.fema.gov/businessinfo.

DATUM INFORMATION

The projection used in the preparation of this map was State Plane Florida West. The horizontal datum was HARN, GRS1980 spheroid. Differences in datum, spheroid, projection or State Plane Zone used in the production of FIRMs for adjacent jurisdictions may result in slight positional differences in map features across jurisdiction boundaries.

Base Flood Elevation (BFEs) on this map are referenced to the North American Vertical Datum of 1988. These flood elevations must be compared to structure and ground elevations referenced to the same vertical datum. For information regarding conversion between the National Geodetic Vertical Datum of 1929 and the North American Vertical Datum of 1988, visit the National Geodetic Survey website at http://www.ngs.noaa.gov/ or contact the National Geodetic Survey at the following address:

NGS Information Services
National Geodetic Survey, NOAA,
NNGS12
SSMCA #9202
1315 East-West Highway
Silver Spring, Maryland 20910-3282
(301) 713-3242

To obtain current elevation, description, and/or location information for benchmarks shown on this map, please contact the Information Services Branch of the National Geodetic Survey at (301) 713-3242 or visit its website at http://www.ngs.noaa.gov/.

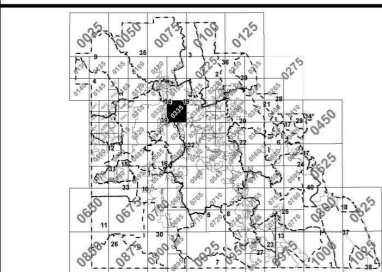
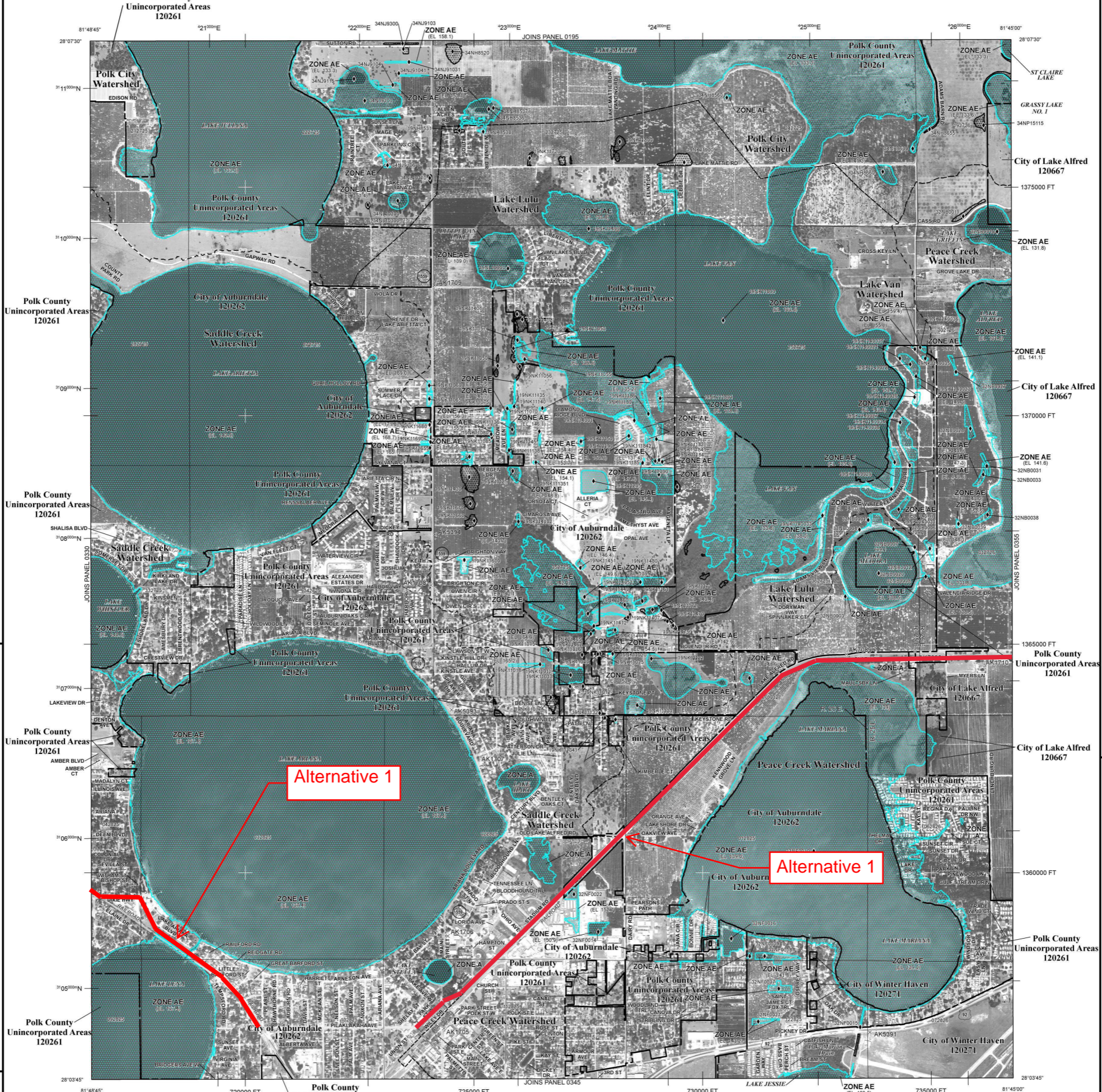

Table with columns: Watershed, Datum Offset (ft), Study Type, Total Rainfall Volume (in) 1 Day 5 Day Multi-Day, and Date of Model. Lists various watersheds and their associated data.

All Polk County watersheds listed. Multi-Day event used only in specific sub-basins, refer to FIS report.

Polk County Unincorporated Areas 120261



Alternative 1

Alternative 1

LEGEND

Legend defining symbols for Special Flood Hazard Areas, Floodway Areas, Other Flood Areas, and Other Areas. Includes scale bars and map repository information.

Map title block: NATIONAL FLOOD INSURANCE PROGRAM, FIRM FLOOD INSURANCE RATE MAP, POLK COUNTY, FLORIDA AND INCORPORATED AREAS. Includes panel number 0335G and date December 22, 2016.

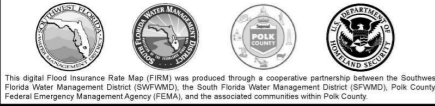

This digital Flood Insurance Rate Map (FIRM) was produced through a cooperative partnership between the Southwest Florida Water Management District (SWFWMD), the South Florida Water Management District (SFWMD), Polk County, Federal Emergency Management Agency (FEMA), and the associated communities within Polk County.

NOTES TO USERS

This map is for use in administering the National Flood Insurance Program. It does not necessarily identify all areas subject to flooding, particularly from local drainage sources of small size. The community map repository should be consulted for possible updated or additional flood hazard information.

To obtain more detailed information in areas where Base Flood Elevations (BFEs) and/or Floodways have been determined, users are encouraged to consult the Flood Profiles and Floodway Data and/or Summary of Stillwater Elevations tables contained within the Flood Insurance Study (FIS) report that accompanies this FIRM. Users should be aware that BFEs shown on the FIRM represent rounded tenth-foot elevations. These BFEs are intended for flood insurance rating purposes only and should not be used as the sole source of flood elevation information.

Coastal Base Flood Elevations (BFEs) shown on this map apply only landward of 0.0' North American Vertical Datum of 1988 (NAVD 88). Users of this FIRM should be aware that coastal flood elevations are also provided in the Summary of Stillwater Elevations table in the Flood Insurance Study report for this jurisdiction. Elevations shown in the Summary of Stillwater Elevations table should be used for construction and/or floodplain management purposes when they are higher than the elevations shown on this FIRM.

Boundaries of the floodways were computed at cross sections and interpolated between cross sections. The floodways were based on hydraulic considerations with regard to requirements of the National Flood Insurance Program. Floodway widths and other pertinent floodway data are provided in the Flood Insurance Study report for this jurisdiction.

Certain areas not in Special Flood Hazard Areas may be protected by flood control structures. Refer to Section 2.4 "Flood Protection Measures" of the Flood Insurance Study report for information on flood control structures for this jurisdiction.

Base map information shown on this FIRM was provided in digital format by the Southwest Florida Water Management District. The original orthophotographic base imagery was provided in color with a one-foot pixel resolution at a scale of 1" = 100' from photography flown January - March 2005.

This map reflects more detailed and up-to-date stream channel configurations than those shown on the previous FIRM for this jurisdiction. The floodplains and floodways that were transferred from the previous FIRM may have been adjusted to conform to these new stream channel configurations. As a result, the Flood Profiles and Floodway Data tables in the Flood Insurance Study report (which contains authoritative hydraulic data) may reflect stream channel distances that differ from what is shown on this map.

Corporate limits shown on this map are based on the best data available at the time of publication. Because changes due to annexations or de-annexations may have occurred after this map was published, map users should contact appropriate community officials to verify current corporate limit locations.

Please refer to the separately printed Map Index for an overview of the county showing the layout of map panels, community map repository addresses, and a Listing of Communities table containing National Flood Insurance Program dates for each community as well as a listing of the panels on which each community is located.

For information on available products associated with this FIRM visit the MapService Center (MSC) website at <http://msc.fema.gov>. Available products may include previously issued Letters of Map Change, a Flood Insurance Study Report, and/or digital versions of this map. Many of these products can be ordered or obtained directly from the MSC website.

If you have questions about this map, how to order products, or the National Flood Insurance Program in general, please call the FEMA Map Information eXchange (FMIX) at 1-877-FEMA-MAP (1-877-336-2627) or visit the FEMA website at <http://www.fema.gov/businessinfo>.

DATUM INFORMATION

The projection used in the preparation of this map was State Plane Florida West. The horizontal datum was HARN, GRS1980 spheroid. Differences in datum, spheroid, projection or State Plane Zone used in the production of FIRMs for adjacent jurisdictions may result in slight positional differences in map features across jurisdiction boundaries. These differences do not reflect the accuracy of this FIRM.

Base Flood Elevation (BFEs) on this map are referenced to the North American Vertical Datum of 1988. These flood elevations must be compared to structure and ground elevations referenced to the same vertical datum. For information regarding conversion between the National Geodetic Vertical Datum of 1929 and the North American Vertical Datum of 1988, visit the National Geodetic Survey website at <http://www.ngs.noaa.gov> or contact the National Geodetic Survey at the following address:

NGS Information Services
National Geodetic Survey, NOAA,
NNGS12
SSMCA, #9202
1315 East West Highway
Silver Spring, Maryland 20910-3282
(301) 713-3242

Example Datum Offset Calculation using datum offset table below
NAVD88 = NGVD29 + (datum offset value)

To obtain current elevation, description, and/or location information for benchmarks shown on this map, please contact the Information Services Branch of the National Geodetic Survey at (301) 713-3242 or visit its website at <http://www.ngs.noaa.gov/>.

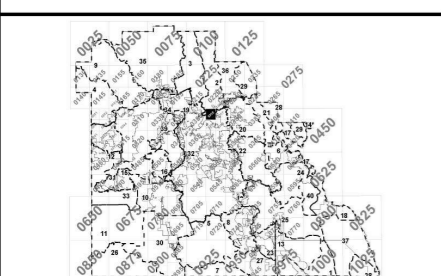

Watershed Boundary

Table with columns: Watershed, Datum Offset (ft), Study Type, Total Rainfall Volume (in) 1 Day, 5 Day, Multi-Day 100yr, 100yr Rainfall Used**, Date of Model. Lists 40 watersheds including Abuckee Creek, Big Creek East, etc.

** All Polk County watersheds listed.
** Multi-Day event used only in specific sub-basins, refer to FIS report.

LEGEND

- SPECIAL FLOOD HAZARD AREAS SUBJECT TO INUNDATION BY THE 1% ANNUAL CHANCE FLOOD
ZONE A No Base Flood Elevations determined.
ZONE AE Base Flood Elevations determined.
... (includes other flood areas, other flood areas, and other otherwise protected areas) ...

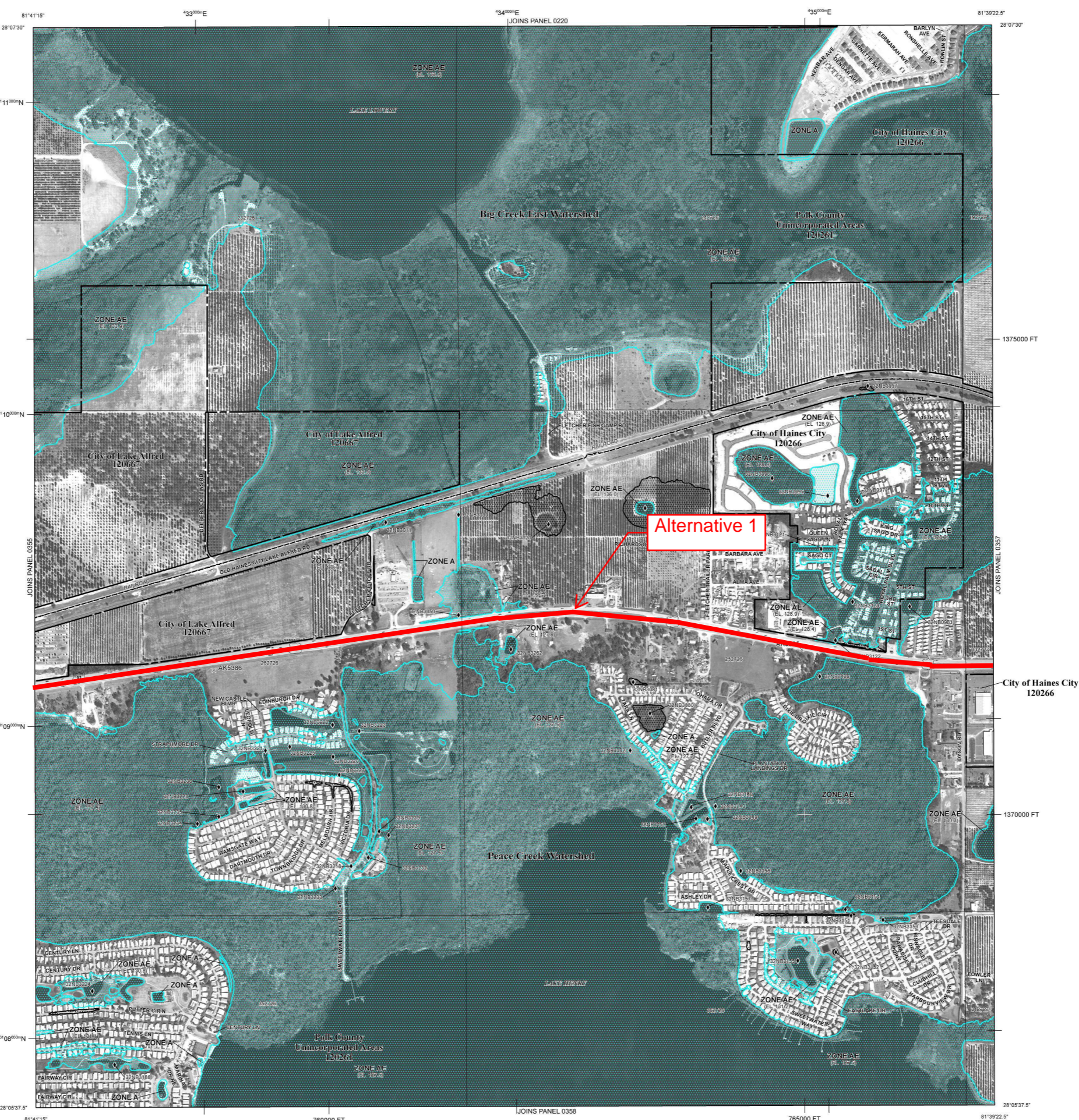

NATIONAL FLOOD INSURANCE PROGRAM
FIRM
FLOOD INSURANCE RATE MAP
POLK COUNTY, FLORIDA AND INCORPORATED AREAS
PANEL 0356G
MAP NUMBER 12105C0356G
MAP REVISED DECEMBER 22, 2016
Federal Emergency Management Agency

This digital Flood Insurance Rate Map (FIRM) was produced through a cooperative partnership between the Southwest Florida Water Management District (SWFWMD), the South Florida Water Management District (SWFWMD), Polk County, and the Federal Emergency Management Agency (FEMA), and the associated communities within Polk County.

NOTES TO USERS

This map is for use in administering the National Flood Insurance Program. It does not necessarily identify all areas subject to flooding...

To obtain more detailed information in areas where Base Flood Elevations (BFEs) and/or Floodways have been determined, users are encouraged to consult the Flood Profiles and Floodway Data and/or Summary of Stillwater Elevations tables contained within the Flood Insurance Study (FIS) report...

Coastal Base Flood Elevations (BFEs) shown on this map apply only landward of 0.0' North American Vertical Datum of 1988 (NAVD 88). Users of this FIRM should be aware that coastal flood elevations are also provided in the Summary of Stillwater Elevations table in the Flood Insurance Study report for this jurisdiction.

Boundaries of the floodways were computed at cross sections and interpolated between cross sections. The floodways were based on hydraulic considerations with regard to requirements of the National Flood Insurance Program.

Certain areas not in Special Flood Hazard Areas may be protected by flood control structures. Refer to Section 2.4 "Flood Protection Measures" of the Flood Insurance Study report for information on flood control structures for this jurisdiction.

Base map information shown on this FIRM was provided in digital format by the Southwest Florida Water Management District. The original orthorectified base imagery was derived from a one-foot pixel resolution at a scale of 1" = 100' from photography flown January - March 2005.

This map reflects more detailed and up-to-date stream channel configurations than those shown on the previous FIRM for this jurisdiction. The floodplains and floodways that were transferred from the previous FIRM may have been adjusted to conform to these new stream channel configurations.

Corporate limits shown on this map are based on the best data available at the time of publication. Because changes due to annexations or de-annexations may have occurred after this map was published, map users should contact appropriate community officials to verify current corporate limit locations.

Please refer to the separately printed Map Index for an overview map of the county showing the layout of map panels, community map repository addresses, and a Listing of Communities table containing National Flood Insurance Program dates for each community as well as a listing of the panels on which each community is located.

For information on available products associated with this FIRM visit the MapService Center (MSC) website at http://msc.fema.gov. Available products may include previously issued Letters of Map Change, a Flood Insurance Study Report, and/or digital versions of this map.

If you have questions about this map, how to order products, or the National Flood Insurance Program in general, please call the FEMA Map Information eXchange (FMIX) at 1-877-FEMA-MAP (1-877-336-2627) or visit the FEMA website at http://www.fema.gov/businessinfo.

DATUM INFORMATION

The projection used in the preparation of this map was State Plane Florida West. The horizontal datum was HARN, GRS1980 spheroid. Differences in datum, spheroid, projection or State Plane Zone used in the production of FIRMs for adjacent jurisdictions may result in slight positional differences in map features across jurisdiction boundaries.

Base Flood Elevation (BFEs) on this map are referenced to the North American Vertical Datum of 1988. These flood elevations must be compared to structure and ground elevations referenced to the same vertical datum.

Example Datum Offset Calculation using datum offset table below: NAVD88 = NGVD29 + (datum offset value)

To obtain current elevation, description, and/or location information for benchmarks shown on this map, please contact the Information Services Branch of the National Geodetic Survey at (301) 713-3242 or visit its website at http://www.ngs.noaa.gov/.

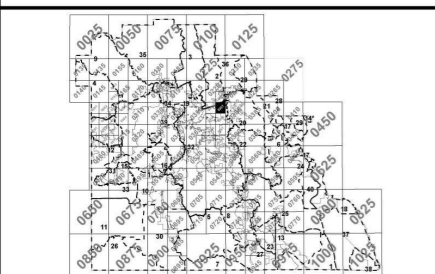
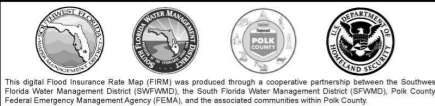

Table with columns: Watershed, Datum Offset (ft), Study Type, Total Rainfall Volume (in) 1 Day 5 Day Multi-Day, Date of Model. Lists various watersheds like Arbutus Creek, Big Creek East, etc.

All Polk County watersheds listed. Multi-Day event used only in specific sub-basins, refer to FIS report.



LEGEND

Legend detailing symbols for Special Flood Hazard Areas Subject to Inundation by the 1% Annual Chance Flood, Floodway Areas in Zone AE, Other Flood Areas, and other geographical features.

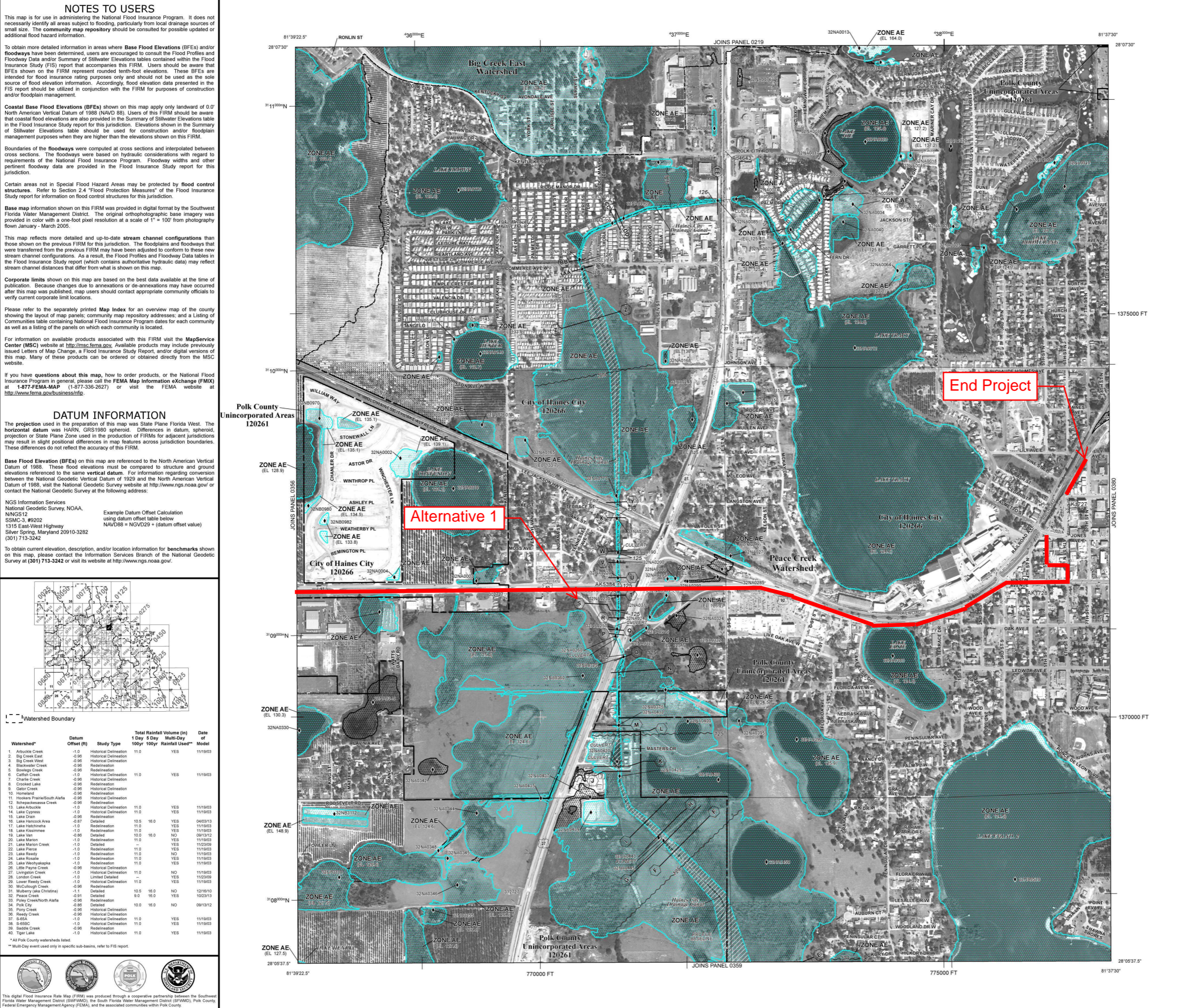

Administrative information including NFIP logo, Panel 0357G, FIRM Flood Insurance Rate Map, Polk County, Florida, and incorporated areas, and the date December 22, 2016.

APPENDIX C:
Field Memo

Old Dixie Trail PD&E

Field Review – August 8, 2019 – Kelly Thomas and Przemyslaw (Chris) Kuzlo – Review of the existing drainage conditions and cross drains for the proposed Old Dixie Trail.

On August 8, 2019, Kelly Thomas and Chris Kuzlo completed a field review for the Old Dixie trail PD&E Project beginning at the intersection of Berkley Road and Deen Blvd. in Auburndale and ending on Park Place in Haines City.

According to the information obtained from Weather Underground, Inc. precipitation values (in inches) for the cities surrounding the proposed trail are summarized in the following table:

	August 6th	August 7th	August 8th
Auburndale, FL (KFLWINT86)	0.34	0.49	0.01
Lake Alfred, FL (KFLLAKEA8)	0.78	0.59	0.04
Haines City, FL (KFLHAINE9)	0.32	1.07	0.01

Field observations and conclusions related to existing drainage conditions are summarized below:

- Large portions of the project limits have no existing drainage infrastructure relying only on sheet flow for stormwater maintenance.
- Many MES structures are overgrown lacking proper maintenance.
- Residents living on Lake Ariana Blvd noted no flooding within that area of the project.
- The existing trail south of Lake Ariana along Pilaklakaha Ave utilizes bioswales to treat and attenuate stormwater runoff.
- Several cross drains will need to be extended to meet FDOT and SFWMD guidelines.
- Potential of recent underdrain construction south of Lake Alfred along W Pierce Street.



CD 12-01
Berkley Road and Deen Blvd.
Single 18" RCP



CD 12-02
Proposed Trail and Harrick Street
Single 15" RCP



CD 12-03
Proposed Trail and James Street
Double 30" RCP



CD 12-04
Proposed Trail and west side of Clayton Rd.
Single 30" RCP



CD 12-05
South of proposed trail east of Clayton Rd.
Double 30" RCP



CD 12-06
Dixie Highway and Seaboard Coast Line
Single 30" RCP



CD 12-07
Ramsgate Road approx. 600-ft south of Lake Ariana
Blvd
Single 18" RCP



CD 12-08
Ramsgate Road approx. 350-ft northwest of
Rafford Road
Box Culvert 10.2' x 8.5'



CD 01-01
Crossing Stadium Road approx. 235-ft west of
Bennett Street.
Single 15" RCP



CD 01-02
Along Stadium Road southwest of Lake
Auburndale Senior High School track and field.
Single 15" RCP



CD 01-03
Along Stadium Road adjacent to Lake Auburndale
Senior High School track and field.
Single 18" RCP



CD 01-04
Stadium Road northeast approx. 1000-ft of CD
01-03
Single 36" RCP



CD 01-05

Old Lake Alfred Road approx. 400-ft west of W
Pierce Street.
Single Box Culvert 4' x 3' Concrete



CD 02-01

SR 600 approx. 60-ft west of 2nd St
Single 15" RCP



CD 02-02

SR 600 and E Bridgers Ave
Single 30" RCP



CD 02-03

SR 600 approx. 200-ft east of Palmetto Drive
Single 36" RCP



CD 02-04

SR 600 and Lake Mariana Drive
Single Box Culvert 10' x 4' Concrete



CD 02-05

SR 600 and Lynchburg Rd
Single 24" RCP



CD 02-06

SR 600 and Club Hill Road
Single Box Culvert 4' x 3' Concrete



CD 02-07

SR 600 approx. 1900-ft east of 21st Street NW
Single Box Culvert 10' x 3' Concrete



CD 02-08

SR 600 approx. 400-ft west of Lock Street
Single Box Culvert 4' x 3' Concrete



CD 02-09

SR 600 and S Buena Vista Drive
Single 36" RCP



CD 12-09

US 17-92 approx. 600-ft east of N Ramona Ave.
Single 36" RCP



CD 12-10

US 17-92 approx. 300-ft west of Mosley Ave.
Single 36" RCP



CD 12-11
US 17-92 approx. 2000-ft east of Lee Jackson Road
Single Box Culvert 6' x 6' Concrete



CD 12-12
US 17-92 approx. 1800-ft west of Woodland Drive
Single 24" RCP



CD 12-13
US 17-92 approx. 300-ft west of Century Drive
Single Box Culvert 7' x 6' Concrete



CD 12-14
US 17-92 approx. 1900-ft west of Sweetwater Club Blvd.
Single 18" RCP



CD 12-15
US 17-92 approx. 1400-ft east of Sweetwater
Club Blvd.
Single 30" RCP



CD 12-16
US 17-92 approx. 400-ft west of Royal Palm Blvd.
Single 36" RCP



CD 12-17
US 17-92 approx. 200-ft west of Watts Dairy Road
Single 18" RCP



CD 12-18
US 17-92 and Moss Ave
Single 18" RCP



CD 12-19
US 17-92 approx. 250-ft west of US 27
Double 4' x 4' Box Culvert

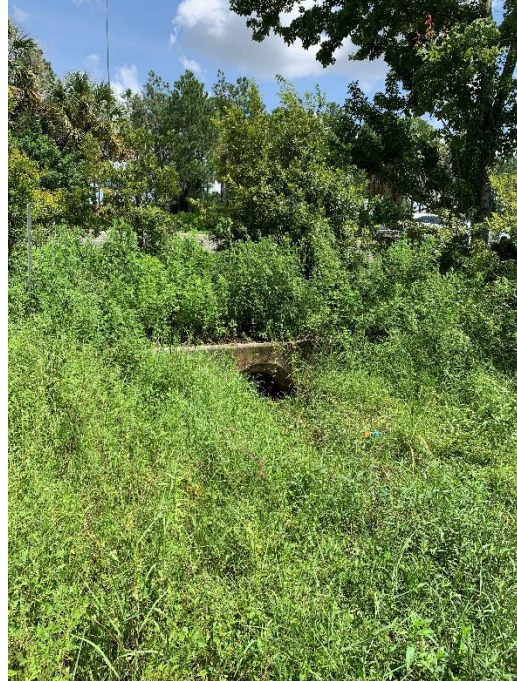

CD 12-20
US 17-92 approx. 250-ft east of US 27
Single 30" RCP



CD 12-21
US 17-92 approx. 150-ft east of Lake Elsie Drive
Single 30" HDPE



Linear ditch system adjacent to Ramsgate Rd.
north of the Lake Ariana Blvd intersection.



Ponding in ditch alongside Ramsgate Road adjacent to cross drain CD 12-07.



Potential recent underdrain installation on the north side of W Pierce Street west of N Nekoma Ave.



Ditch collection along south side of SR 600 west of 21st St NW.



Side drain collection on north side of SR 600 at Idle Lane.

APPENDIX D:
HY-8 Models

**Cross Drain
01**

CD 01

CD 01 data was not found in an existing watershed model. The discharge rates are estimated based on the existing cross drain diameter per FDOT Drainage Design Guide Section 4.7.1 Method 1.

SWFWMD ERP Permit 31455.000 was used to determine the CD 01 has 24”RCP with a length of 200.4’.

Estimated discharges as follows:

i. 25 yr. $Q = AV$

where A = Existing Culvert Area

V = 6 feet per second (Confirm this value with the District Drainage Engineer; some districts use a lower velocity)

ii. 100 yr. $Q = 1.4 \times (25 \text{ yr } Q)$

iii. 500 yr. $Q = 1.7 \times (100 \text{ yr } Q)$

The 50 year design storm discharge rate was found using Figure A-1 below. A logarithmic trendline with an R-squared value equal to 1 was used to get the formula for the 50 year design storm discharge rate. Results are found in Table A-2.

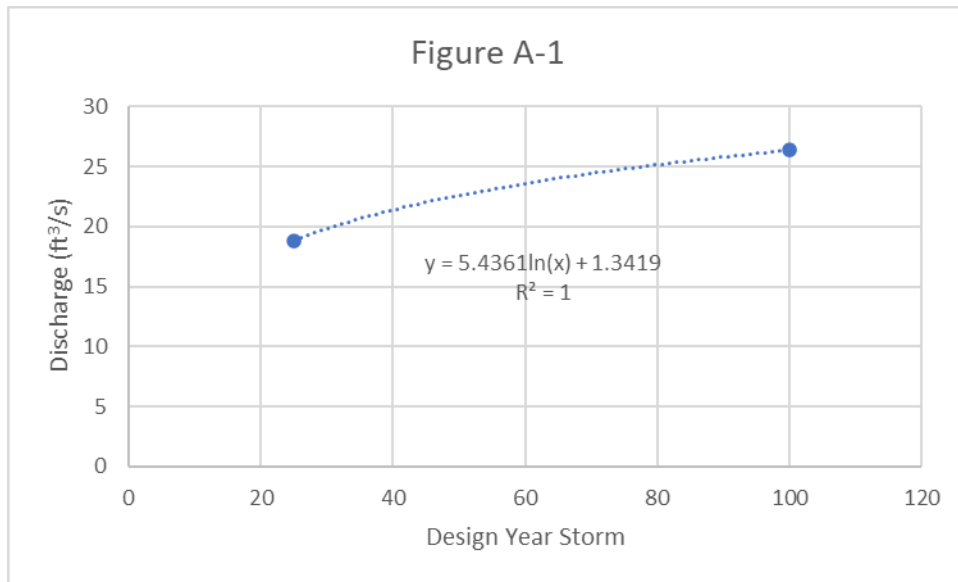

A	3.14
Q(25)	18.8
Q(50)	22.6
Q(100)	26.4
Q(500)	44.8

Table A-2

HY-8 Culvert Analysis Report

Crossing Discharge Data

Discharge Selection Method: Specify Minimum, Design, and Maximum Flow

Minimum Flow: 22.60 cfs

Design Flow: 26.40 cfs

Maximum Flow: 44.80 cfs

Table 1 - Summary of Culvert Flows at Crossing: CD 01 Pre

Headwater Elevation (ft)	Total Discharge (cfs)	24in pipe Discharge (cfs)	Roadway Discharge (cfs)	Iterations
151.43	22.60	22.60	0.00	1
151.98	24.82	24.82	0.00	1
152.40	26.40	26.40	0.00	1
152.74	29.26	27.60	1.41	45
152.74	31.48	27.62	3.59	4
152.75	33.70	27.64	5.92	4
152.75	35.92	27.65	8.01	3
152.75	38.14	27.66	10.26	3
152.76	40.36	27.67	12.52	3
152.76	42.58	27.68	14.78	3
152.76	44.80	27.69	17.02	3
152.73	27.58	27.58	0.00	Overtopping

Rating Curve Plot for Crossing: CD 01 Pre

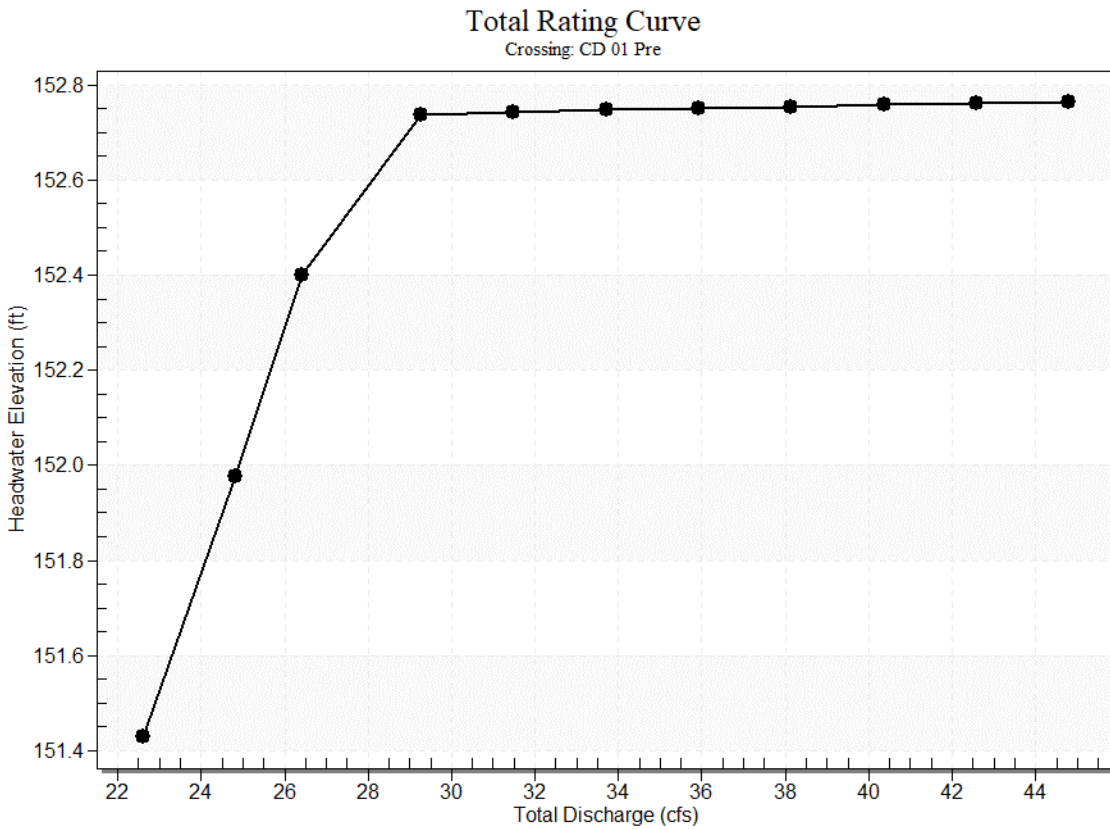

Culvert Data: 24in pipe

Table 1 - Culvert Summary Table: 24in pipe

Total Discharge (cfs)	Culvert Discharge (cfs)	Headwater Elevation (ft)	Inlet Control Depth (ft)	Outlet Control Depth (ft)	Flow Type	Normal Depth (ft)	Critical Depth (ft)	Outlet Depth (ft)	Tailwater Depth (ft)	Outlet Velocity (ft/s)	Tailwater Velocity (ft/s)
22.60 cfs	22.60 cfs	151.43	3.17	3.969	4-FFf	2.00	1.69	2.00	2.00	7.19	0.00
24.82 cfs	24.82 cfs	151.98	3.55	4.517	4-FFf	2.00	1.76	2.00	2.00	7.90	0.00
26.40 cfs	26.40 cfs	152.40	3.84	4.938	4-FFf	2.00	1.80	2.00	2.00	8.40	0.00
29.26 cfs	27.60 cfs	152.74	4.07	5.276	4-FFf	2.00	1.82	2.00	2.00	8.79	0.00
31.48 cfs	27.62 cfs	152.74	4.08	5.281	4-FFf	2.00	1.82	2.00	2.00	8.79	0.00
33.70 cfs	27.64 cfs	152.75	4.08	5.286	4-FFf	2.00	1.82	2.00	2.00	8.80	0.00

35.92 cfs	27.65 cfs	152.75	4.08	5.28 9	4- FFf	2.00	1.82	2.00	2.00	8.80	0.00
38.14 cfs	27.66 cfs	152.75	4.09	5.29 3	4- FFf	2.00	1.82	2.00	2.00	8.80	0.00
40.36 cfs	27.67 cfs	152.76	4.09	5.29 6	4- FFf	2.00	1.82	2.00	2.00	8.81	0.00
42.58 cfs	27.68 cfs	152.76	4.09	5.29 9	4- FFf	2.00	1.82	2.00	2.00	8.81	0.00
44.80 cfs	27.69 cfs	152.76	4.09	5.30 2	4- FFf	2.00	1.82	2.00	2.00	8.81	0.00

Culvert Barrel Data

Culvert Barrel Type Straight Culvert

Inlet Elevation (invert): 147.46 ft,

Outlet Elevation (invert): 146.77 ft

Culvert Length: 200.40 ft,

Culvert Slope: 0.0034

Culvert Performance Curve Plot: 24in pipe

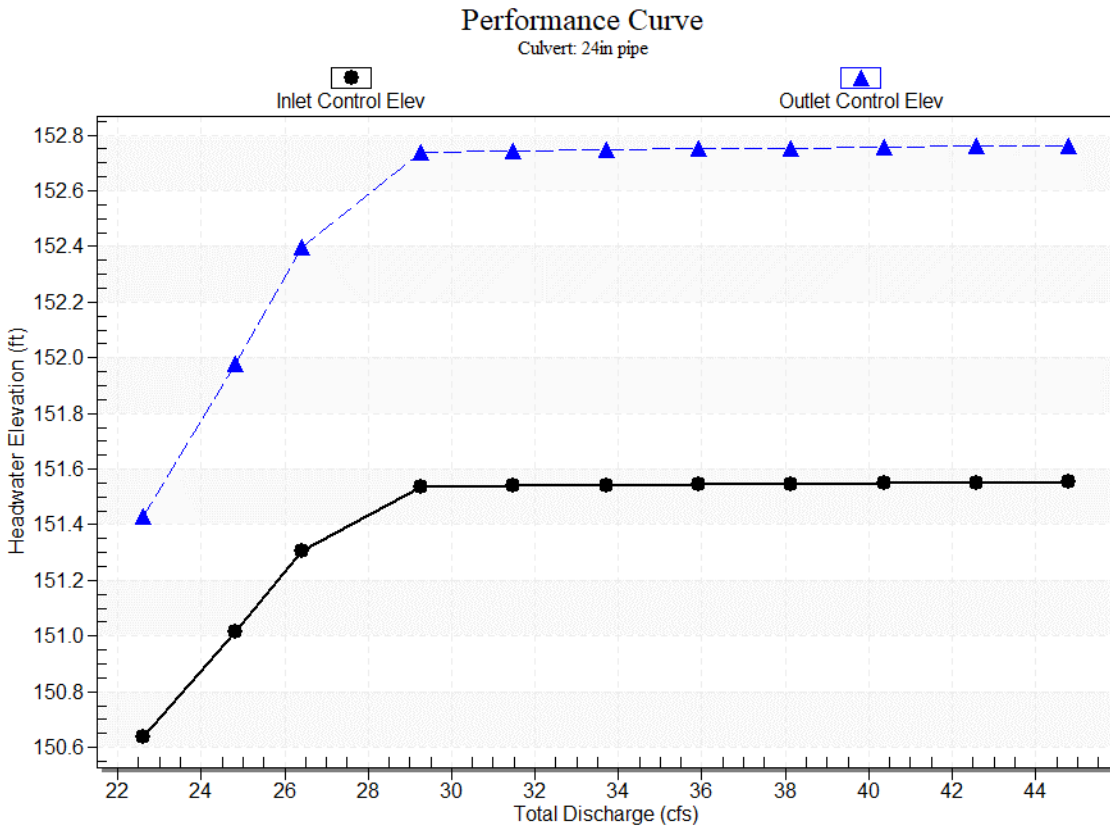

Water Surface Profile Plot for Culvert: 24in pipe

Crossing - CD 01 Pre, Design Discharge - 26.4 cfs

Culvert - 24in pipe, Culvert Discharge - 26.4 cfs

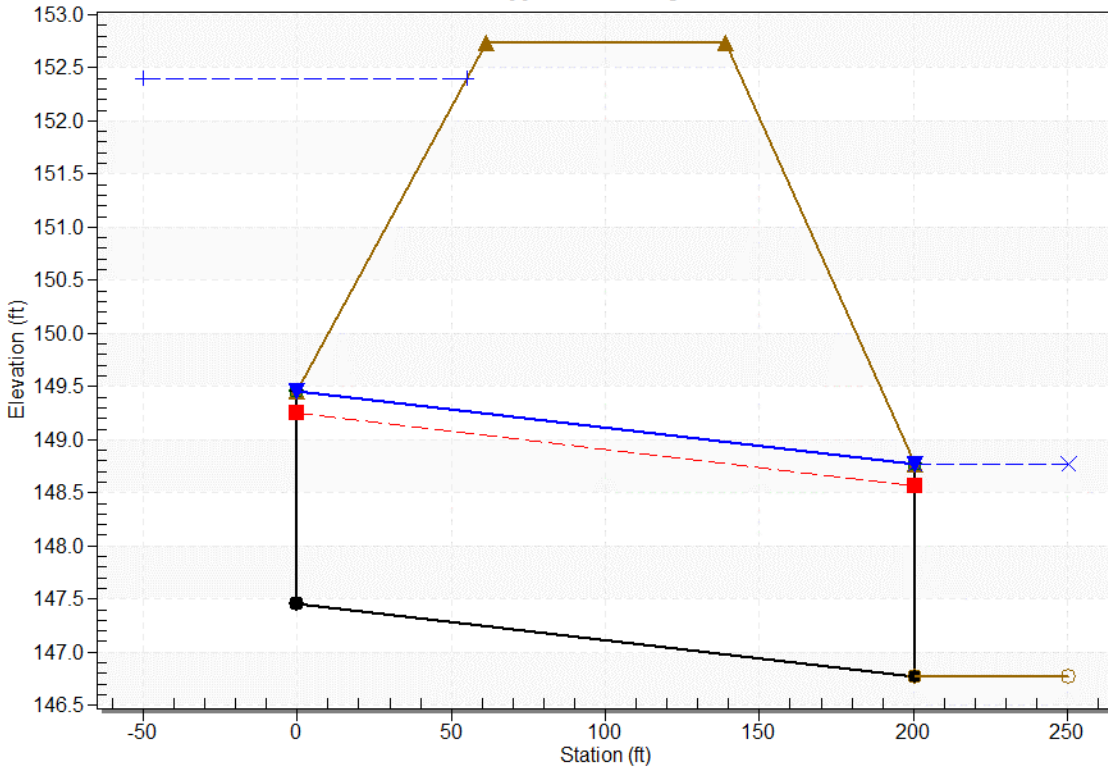

Site Data - 24in pipe

Site Data Option: Culvert Invert Data

Inlet Station: 0.00 ft

Inlet Elevation: 147.46 ft

Outlet Station: 200.40 ft

Outlet Elevation: 146.77 ft

Number of Barrels: 1

Culvert Data Summary - 24in pipe

Barrel Shape: Circular

Barrel Diameter: 2.00 ft

Barrel Material: Concrete

Embedment: 0.00 in

Barrel Manning's n: 0.0120

Culvert Type: Straight

Inlet Configuration: Beveled Edge (1:1) (Ke=0.2)

Inlet Depression: None

Tailwater Data for Crossing: CD 01 Pre

Table 2 - Downstream Channel Rating Curve (Crossing: CD 01 Pre)

Flow (cfs)	Water Surface Elev (ft)	Depth (ft)
22.60	148.77	2.00
24.82	148.77	2.00
26.40	148.77	2.00
29.26	148.77	2.00
31.48	148.77	2.00
33.70	148.77	2.00
35.92	148.77	2.00
38.14	148.77	2.00
40.36	148.77	2.00
42.58	148.77	2.00
44.80	148.77	2.00

Tailwater Channel Data - CD 01 Pre

Tailwater Channel Option: Enter Constant Tailwater Elevation

Constant Tailwater Elevation: 148.77 ft

Roadway Data for Crossing: CD 01 Pre

Roadway Profile Shape: Constant Roadway Elevation

Crest Length: 1000.00 ft

Crest Elevation: 152.73 ft

Roadway Surface: Paved

Roadway Top Width: 78.00 ft

Crossing Discharge Data

Discharge Selection Method: Specify Minimum, Design, and Maximum Flow

Minimum Flow: 22.60 cfs

Design Flow: 26.40 cfs

Maximum Flow: 44.80 cfs

Table 3 - Summary of Culvert Flows at Crossing: CD 01 Post

Headwater Elevation (ft)	Total Discharge (cfs)	30in pipe Discharge (cfs)	Roadway Discharge (cfs)	Iterations
149.94	22.60	22.60	0.00	1
150.10	24.82	24.82	0.00	1
150.22	26.40	26.40	0.00	1
150.46	29.26	29.26	0.00	1
150.70	31.48	31.48	0.00	1
151.06	33.70	33.70	0.00	1
151.40	35.92	35.92	0.00	1
151.75	38.14	38.14	0.00	1
152.11	40.36	40.36	0.00	1
152.49	42.58	42.58	0.00	1
152.73	44.80	44.00	0.36	60
152.73	43.95	43.95	0.00	Overtopping

Rating Curve Plot for Crossing: CD 01 Post

Total Rating Curve

Crossing: CD 01 Post

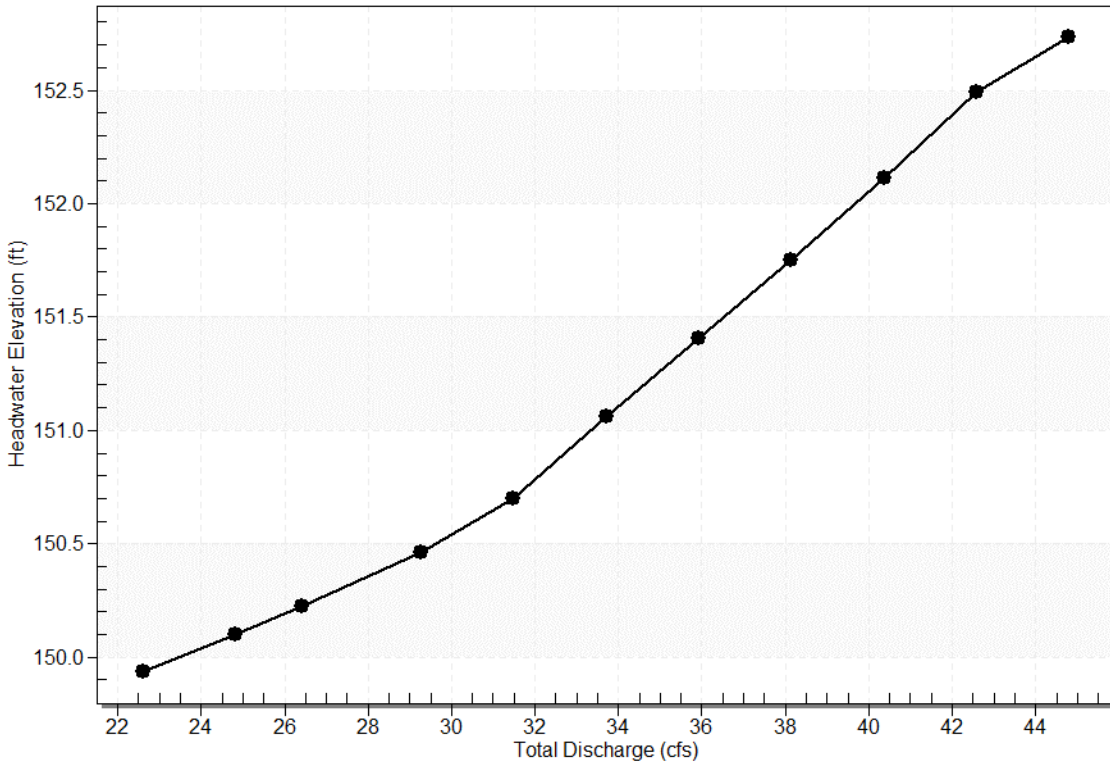

Culvert Data: 30in pipe

Table 2 - Culvert Summary Table: 30in pipe

Total Discharge (cfs)	Culvert Discharge (cfs)	Headwater Elevation (ft)	Inlet Control Depth (ft)	Outlet Control Depth (ft)	Flow Type	Normal Depth (ft)	Critical Depth (ft)	Outlet Depth (ft)	Tailwater Depth (ft)	Outlet Velocity (ft/s)	Tailwater Velocity (ft/s)
22.60 cfs	22.60 cfs	149.94	2.42	2.47	3-t M1	1.79	1.62	2.08	2.07	5.18	0.00
24.82 cfs	24.82 cfs	150.10	2.58	2.64	7-t M1	1.94	1.70	2.08	2.07	5.69	0.00
26.40 cfs	26.40 cfs	150.22	2.70	2.76	7-t M1	2.07	1.75	2.08	2.07	6.05	0.00
29.26 cfs	29.26 cfs	150.46	2.94	3.00	3-t M2	2.50	1.84	2.08	2.07	6.70	0.00

31.48 cfs	31.48 cfs	150.70	3.13	3.24 1	3- M2 t	2.50	1.91	2.08	2.07	7.21	0.00
33.70 cfs	33.70 cfs	151.06	3.35	3.60 2	7- M2 t	2.50	1.97	2.08	2.07	7.72	0.00
35.92 cfs	35.92 cfs	151.40	3.57	3.94 3	7- M2 t	2.50	2.03	2.08	2.07	8.23	0.00
38.14 cfs	38.14 cfs	151.75	3.81	4.29 1	7- M2 c	2.50	2.09	2.09	2.07	8.71	0.00
40.36 cfs	40.36 cfs	152.11	4.07	4.65 3	7- M2 c	2.50	2.14	2.14	2.07	9.03	0.00
42.58 cfs	42.58 cfs	152.49	4.34	5.03 1	7- M2 c	2.50	2.18	2.18	2.07	9.37	0.00
44.80 cfs	44.00 cfs	152.73	4.52	5.27 2	7- M2 c	2.50	2.21	2.21	2.07	9.59	0.00

Culvert Barrel Data

Culvert Barrel Type Straight Culvert

Inlet Elevation (invert): 147.46 ft,

Outlet Elevation (invert): 146.69 ft

Culvert Length: 223.40 ft,

Culvert Slope: 0.0034

Culvert Performance Curve Plot: 30in pipe

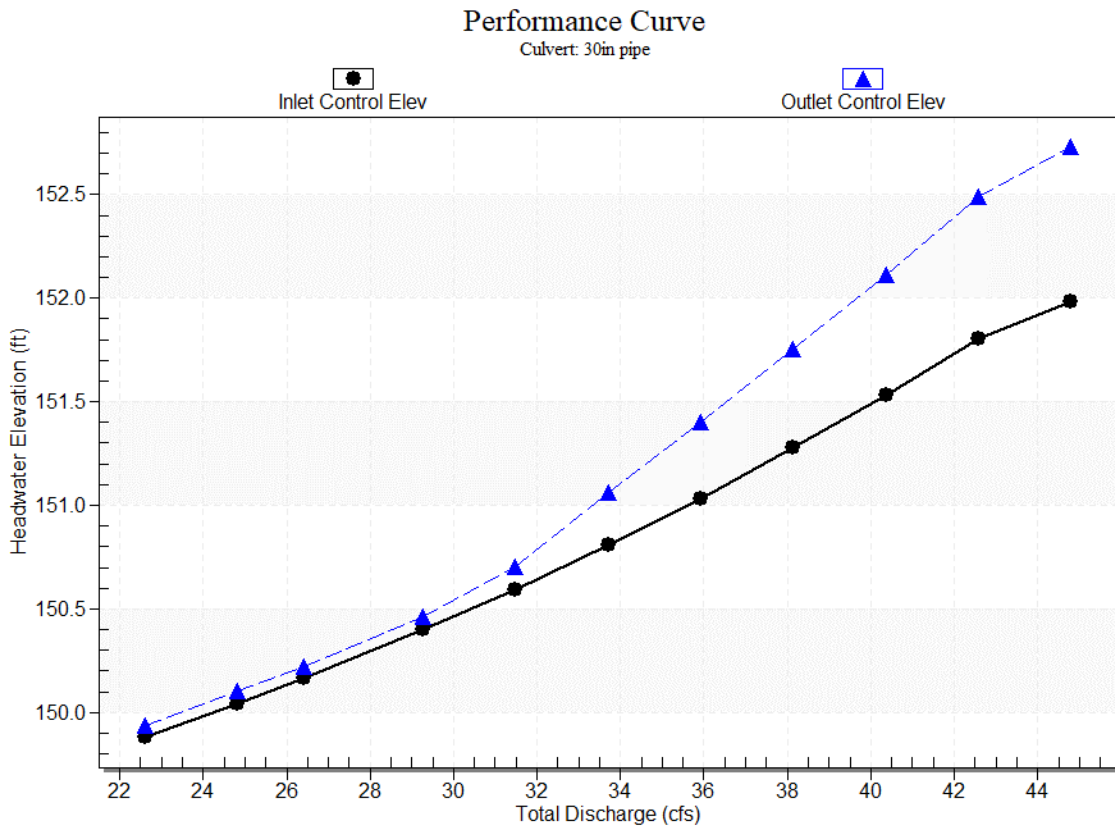

Water Surface Profile Plot for Culvert: 30in pipe

Crossing - CD 01 Post, Design Discharge - 26.4 cfs

Culvert - 30in pipe, Culvert Discharge - 26.4 cfs

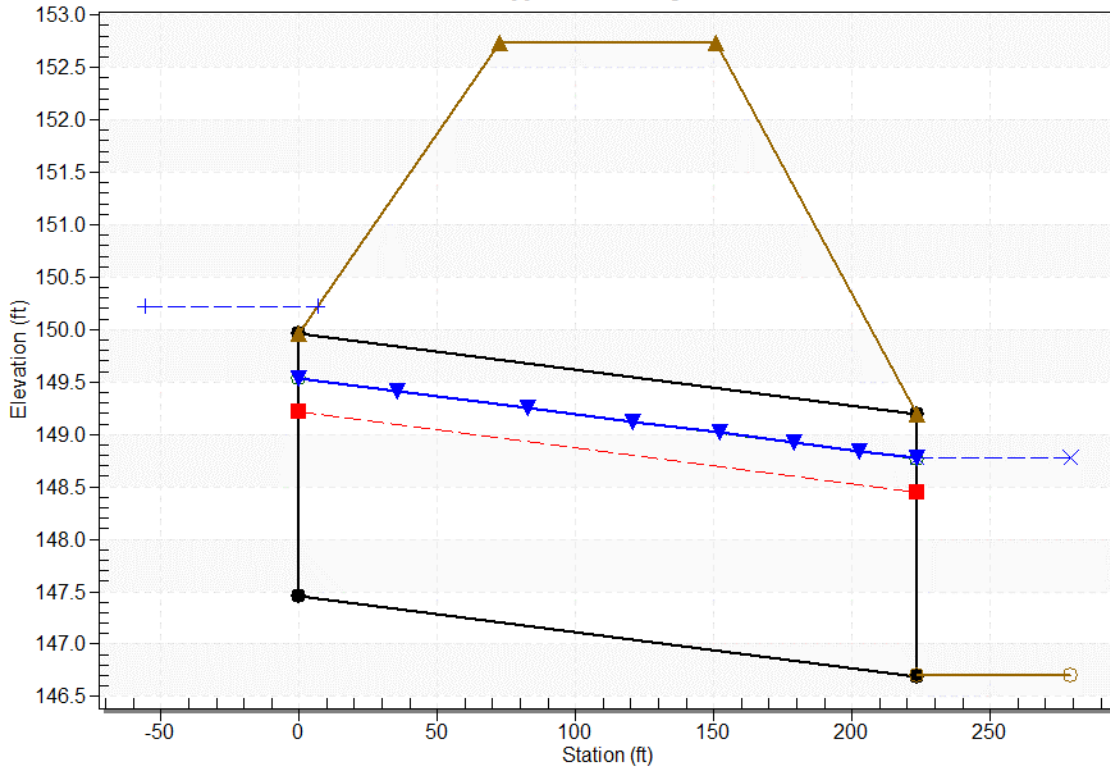

Site Data - 30in pipe

Site Data Option: Culvert Invert Data

Inlet Station: 0.00 ft

Inlet Elevation: 147.46 ft

Outlet Station: 223.40 ft

Outlet Elevation: 146.69 ft

Number of Barrels: 1

Culvert Data Summary - 30in pipe

Barrel Shape: Circular

Barrel Diameter: 2.50 ft

Barrel Material: Concrete

Embedment: 0.00 in

Barrel Manning's n: 0.0120

Culvert Type: Straight

Inlet Configuration: Beveled Edge (1:1) (Ke=0.2)

Inlet Depression: None

Tailwater Data for Crossing: CD 01 Post

Table 4 - Downstream Channel Rating Curve (Crossing: CD 01 Post)

Flow (cfs)	Water Surface Elev (ft)	Depth (ft)
22.60	148.77	2.07
24.82	148.77	2.07
26.40	148.77	2.07
29.26	148.77	2.07
31.48	148.77	2.07
33.70	148.77	2.07
35.92	148.77	2.07
38.14	148.77	2.07
40.36	148.77	2.07
42.58	148.77	2.07
44.80	148.77	2.07

Tailwater Channel Data - CD 01 Post

Tailwater Channel Option: Enter Constant Tailwater Elevation

Constant Tailwater Elevation: 148.77 ft

Roadway Data for Crossing: CD 01 Post

Roadway Profile Shape: Constant Roadway Elevation

Crest Length: 1000.00 ft

Crest Elevation: 152.73 ft

Roadway Surface: Paved

Roadway Top Width: 78.00 ft

Cross Drain
08

Pipe Link: R1420A	Upstream	Downstream
Scenario: Icp3	Invert: 136.70 ft	Invert: 132.66 ft
From Node: N1420	Manning's N: 0.0120	Manning's N: 0.0120
To Node: N1410	Geometry: Rectangular	Geometry: Rectangular
Link Count: 1	Max Depth: 8.50 ft	Max Depth: 8.50 ft
Flow Direction: Both	Max Width: 10.20 ft	Max Width: 10.20 ft
Damping: 0.0000 ft	Fillet: 0.00 ft	Fillet: 0.00 ft
Length: 42.00 ft	Bottom Clip	
FHWA Code: 9	Default: 0.00 ft	Default: 0.00 ft
Entr Loss Coef: 0.40	Op Table:	Op Table:
Exit Loss Coef: 0.00	Ref Node:	Ref Node:
Bend Loss Coef: 0.00	Manning's N: 0.0120	Manning's N: 0.0120
Bend Location: 0.00 dec	Top Clip	
Energy Switch: Energy	Default: 0.00 ft	Default: 0.00 ft
	Op Table:	Op Table:
	Ref Node:	Ref Node:
	Manning's N: 0.0120	Manning's N: 0.0120
Comment:		

Sim	Link Name	Maximum Flow Rate [cfs]	Time to Maximum Flow Rate [hrs]	Minimum Flow Rate [cfs]	Time to Minimum Flow Rate [hrs]
050Y120H	R1420A	71.91	184.9283	-32.48	67.8506
100Y120H	R1420A	93.42	181.1981	-50.72	67.4507
500Y120H	R1420A	132.97	169.4924	-86.86	67.1614

HY-8 Culvert Analysis Report

Crossing Discharge Data

Discharge Selection Method: Specify Minimum, Design, and Maximum Flow

Minimum Flow: 71.91 cfs

Design Flow: 93.42 cfs

Maximum Flow: 132.97 cfs

Table 1 - Summary of Culvert Flows at Crossing: CD 08 Pre

Headwater Elevation (ft)	Total Discharge (cfs)	10.2ftx8.5ft Discharge (cfs)	Roadway Discharge (cfs)	Iterations
141.18	71.91	71.91	0.00	1
141.19	78.02	78.02	0.00	1
141.19	84.12	84.12	0.00	1
141.20	90.23	90.23	0.00	1
141.20	93.42	93.42	0.00	1
141.21	102.44	102.44	0.00	1
141.22	108.55	108.55	0.00	1
141.22	114.65	114.65	0.00	1
141.23	120.76	120.76	0.00	1
141.24	126.86	126.86	0.00	1
141.25	132.97	132.97	0.00	1
143.62	904.15	904.15	0.00	Overtopping

Rating Curve Plot for Crossing: CD 08 Pre

Total Rating Curve
Crossing: CD 08 Pre

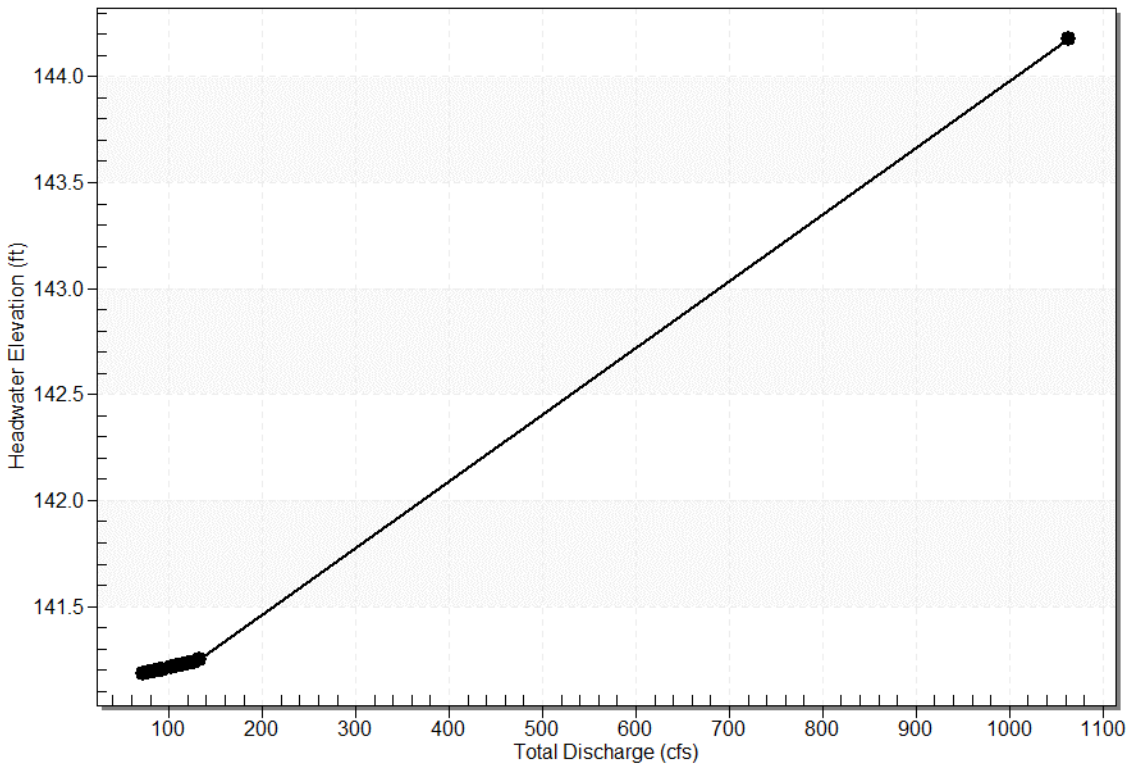

Culvert Data: 10.2ftx8.5ft

Table 1 - Culvert Summary Table: 10.2ftx8.5ft

Total Discharge (cfs)	Culvert Discharge (cfs)	Headwater Elevation (ft)	Inlet Control Depth (ft)	Outlet Control Depth (ft)	Flow Type	Normal Depth (ft)	Critical Depth (ft)	Outlet Depth (ft)	Tailwater Depth (ft)	Outlet Velocity (ft/s)	Tailwater Velocity (ft/s)
71.91 cfs	71.91 cfs	141.18	1.77	8.484	3-M1f	1.61	1.16	8.50	8.50	0.83	0.00
78.02 cfs	78.02 cfs	141.19	1.87	8.489	3-M1f	1.70	1.22	8.50	8.50	0.90	0.00
84.12 cfs	84.12 cfs	141.19	1.97	8.494	3-M1f	1.79	1.28	8.50	8.50	0.97	0.00
90.23 cfs	90.23 cfs	141.20	2.06	8.499	3-M1f	1.87	1.34	8.50	8.50	1.04	0.00

93.42 cfs	93.42 cfs	141.20	2.11	8.50 2	3- M1 f	1.92	1.38	8.50	8.50	1.08	0.00
102.4 4 cfs	102.44 cfs	141.21	2.25	8.51 1	3- M1 f	2.04	1.46	8.50	8.50	1.18	0.00
108.5 5 cfs	108.55 cfs	141.22	2.34	8.51 8	3- M1 f	2.12	1.52	8.50	8.50	1.25	0.00
114.6 5 cfs	114.65 cfs	141.22	2.42	8.52 4	3- M1 f	2.20	1.58	8.50	8.50	1.32	0.00
120.7 6 cfs	120.76 cfs	141.23	2.51	8.53 2	3- M1 f	2.28	1.63	8.50	8.50	1.39	0.00
126.8 6 cfs	126.86 cfs	141.24	2.59	8.53 9	3- M1 f	2.36	1.69	8.50	8.50	1.46	0.00
132.9 7 cfs	132.97 cfs	141.25	2.67	8.54 7	3- M1 f	2.44	1.74	8.50	8.50	1.53	0.00

Culvert Barrel Data

Culvert Barrel Type Straight Culvert

Inlet Elevation (invert): 132.70 ft,

Outlet Elevation (invert): 132.66 ft

Culvert Length: 42.00 ft,

Culvert Slope: 0.0010

Culvert Performance Curve Plot: 10.2ftx8.5ft

Performance Curve

Culvert: 10.2ftx8.5ft

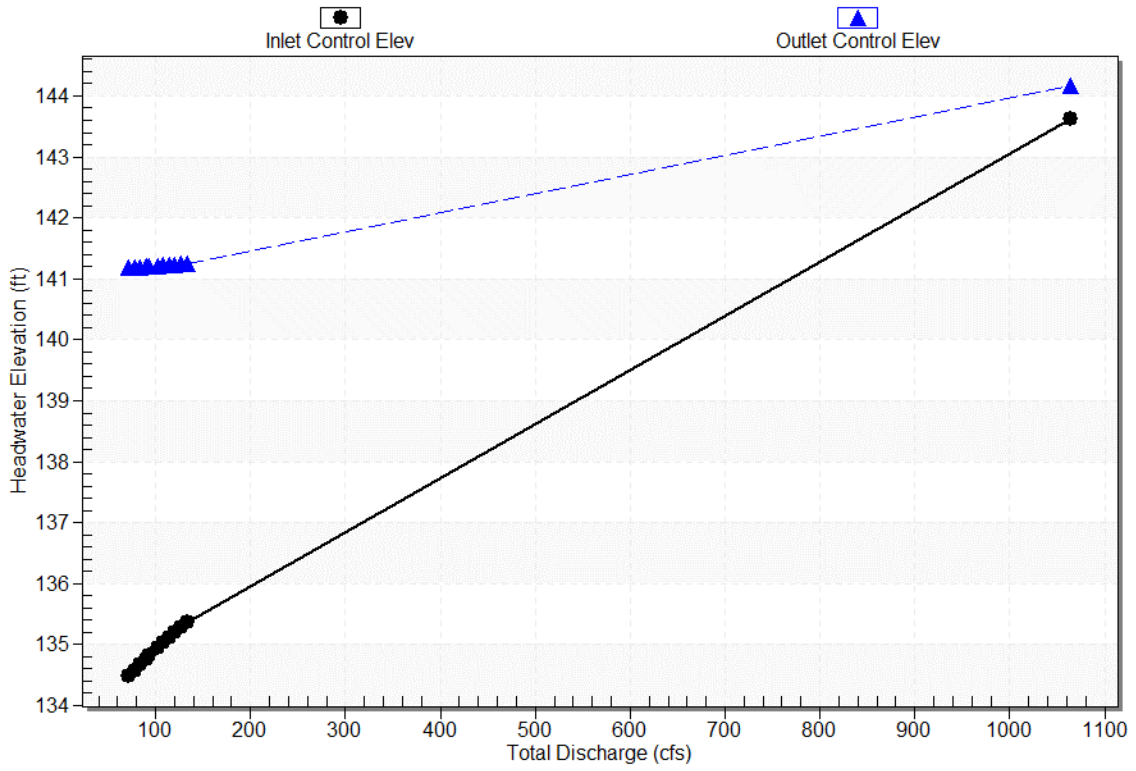

Water Surface Profile Plot for Culvert: 10.2ftx8.5ft

Crossing - CD 08 Pre, Design Discharge - 93.4 cfs

Culvert - 10.2ftx8.5ft, Culvert Discharge - 93.4 cfs

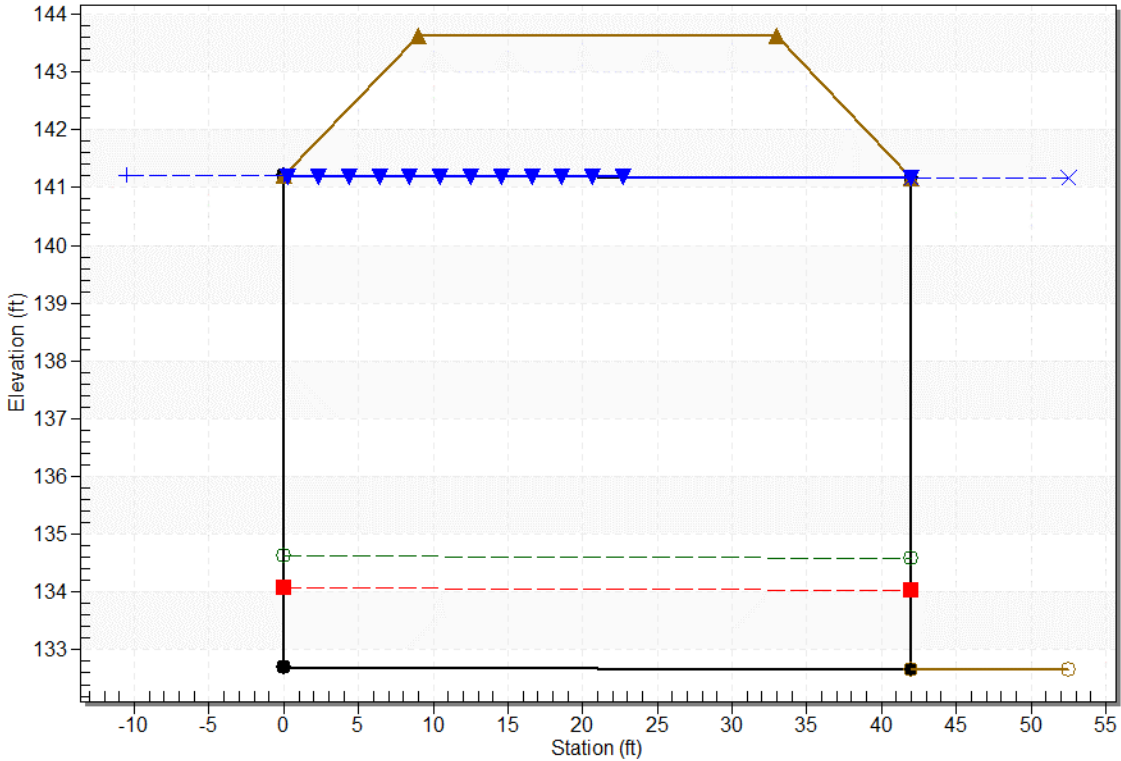

Site Data - 10.2ftx8.5ft

Site Data Option: Culvert Invert Data

Inlet Station: 0.00 ft

Inlet Elevation: 132.70 ft

Outlet Station: 42.00 ft

Outlet Elevation: 132.66 ft

Number of Barrels: 1

Culvert Data Summary - 10.2ftx8.5ft

Barrel Shape: Concrete Box

Barrel Span: 10.20 ft

Barrel Rise: 8.50 ft

Barrel Material: Concrete

Embedment: 0.00 in

Barrel Manning's n: 0.0120

Culvert Type: Straight

Inlet Configuration: Square Edge (30-75° flare) Wingwall (Ke=0.4)

Inlet Depression: None

Tailwater Data for Crossing: CD 08 Pre

Table 2 - Downstream Channel Rating Curve (Crossing: CD 08 Pre)

Flow (cfs)	Water Surface Elev (ft)	Depth (ft)
71.91	141.16	8.50
78.02	141.16	8.50
84.12	141.16	8.50
90.23	141.16	8.50
93.42	141.16	8.50
102.44	141.16	8.50
108.55	141.16	8.50
114.65	141.16	8.50
120.76	141.16	8.50
126.86	141.16	8.50
132.97	141.16	8.50

Tailwater Channel Data - CD 08 Pre

Tailwater Channel Option: Enter Constant Tailwater Elevation

Constant Tailwater Elevation: 141.16 ft

Roadway Data for Crossing: CD 08 Pre

Roadway Profile Shape: Constant Roadway Elevation

Crest Length: 50.00 ft

Crest Elevation: 143.62 ft

Roadway Surface: Paved

Roadway Top Width: 24.00 ft

Crossing Discharge Data

Discharge Selection Method: Specify Minimum, Design, and Maximum Flow

Minimum Flow: 71.91 cfs

Design Flow: 93.42 cfs

Maximum Flow: 132.97 cfs

Table 3 - Summary of Culvert Flows at Crossing: CD 08 Post

Headwater Elevation (ft)	Total Discharge (cfs)	10.2ftx8.5ft Discharge (cfs)	Roadway Discharge (cfs)	Iterations
141.18	71.91	71.91	0.00	1
141.19	78.02	78.02	0.00	1
141.19	84.12	84.12	0.00	1
141.20	90.23	90.23	0.00	1
141.20	93.42	93.42	0.00	1
141.21	102.44	102.44	0.00	1
141.22	108.55	108.55	0.00	1
141.22	114.65	114.65	0.00	1
141.23	120.76	120.76	0.00	1
141.24	126.86	126.86	0.00	1
141.25	132.97	132.97	0.00	1
143.62	900.79	900.79	0.00	Overtopping

Rating Curve Plot for Crossing: CD 08 Post

Total Rating Curve

Crossing: CD 08 Post

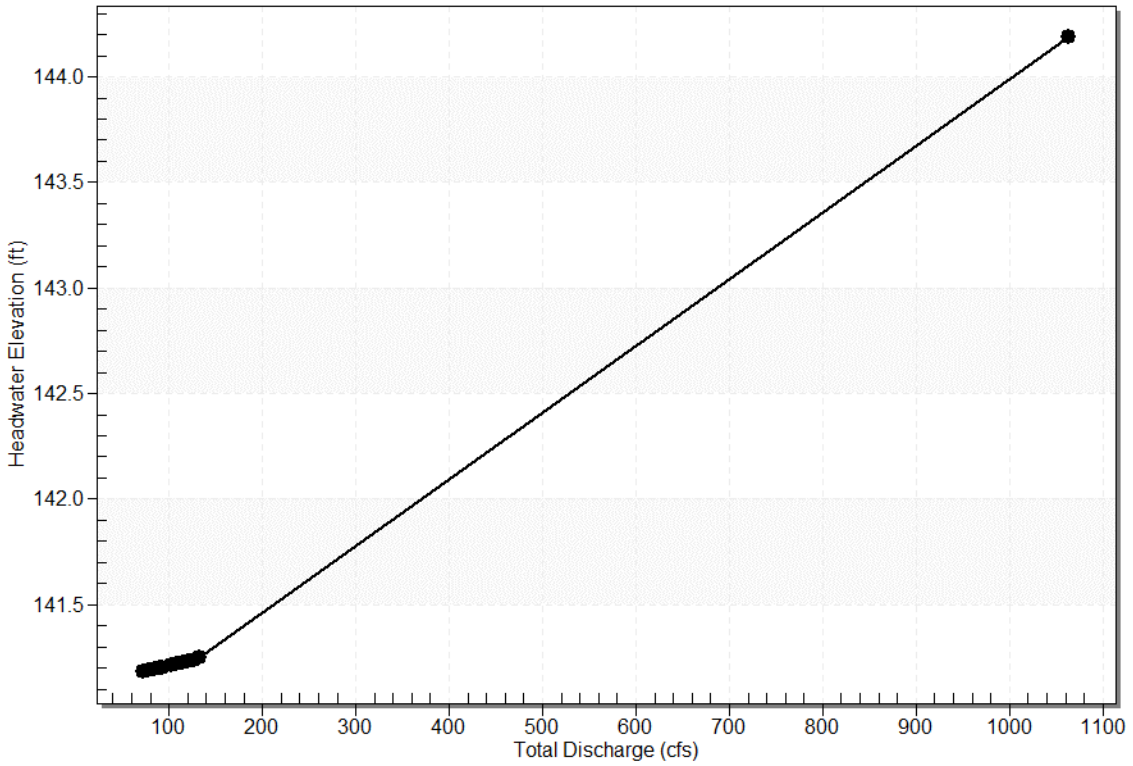

Culvert Data: 10.2ftx8.5ft

Table 2 - Culvert Summary Table: 10.2ftx8.5ft

Total Discharge (cfs)	Culvert Discharge (cfs)	Headwater Elevation (ft)	Inlet Control Depth (ft)	Outlet Control Depth (ft)	Flow Type	Normal Depth (ft)	Critical Depth (ft)	Outlet Depth (ft)	Tailwater Depth (ft)	Outlet Velocity (ft/s)	Tailwater Velocity (ft/s)
71.91 cfs	71.91 cfs	141.18	1.77	8.474	3-M1f	1.58	1.16	8.50	8.50	0.83	0.00
78.02 cfs	78.02 cfs	141.19	1.87	8.478	3-M1f	1.67	1.22	8.50	8.50	0.90	0.00
84.12 cfs	84.12 cfs	141.19	1.97	8.483	3-M1f	1.76	1.28	8.50	8.50	0.97	0.00
90.23 cfs	90.23 cfs	141.20	2.06	8.489	3-M1f	1.84	1.34	8.50	8.50	1.04	0.00

93.42 cfs	93.42 cfs	141.20	2.11	8.49 2	3- M1 f	1.88	1.38	8.50	8.50	1.08	0.00
102.4 4 cfs	102.44 cfs	141.21	2.25	8.50 1	3- M1 f	2.01	1.46	8.50	8.50	1.18	0.00
108.5 5 cfs	108.55 cfs	141.22	2.34	8.50 7	3- M1 f	2.09	1.52	8.50	8.50	1.25	0.00
114.6 5 cfs	114.65 cfs	141.22	2.42	8.51 4	3- M1 f	2.17	1.58	8.50	8.50	1.32	0.00
120.7 6 cfs	120.76 cfs	141.23	2.51	8.52 1	3- M1 f	2.24	1.63	8.50	8.50	1.39	0.00
126.8 6 cfs	126.86 cfs	141.24	2.59	8.52 9	3- M1 f	2.32	1.69	8.50	8.50	1.46	0.00
132.9 7 cfs	132.97 cfs	141.25	2.67	8.53 7	3- M1 f	2.40	1.74	8.50	8.50	1.53	0.00

Culvert Barrel Data

Culvert Barrel Type Straight Culvert

Inlet Elevation (invert): 132.71 ft,

Outlet Elevation (invert): 132.66 ft

Culvert Length: 50.00 ft,

Culvert Slope: 0.0010

Culvert Performance Curve Plot: 10.2ftx8.5ft

Performance Curve
Culvert: 10.2ftx8.5ft

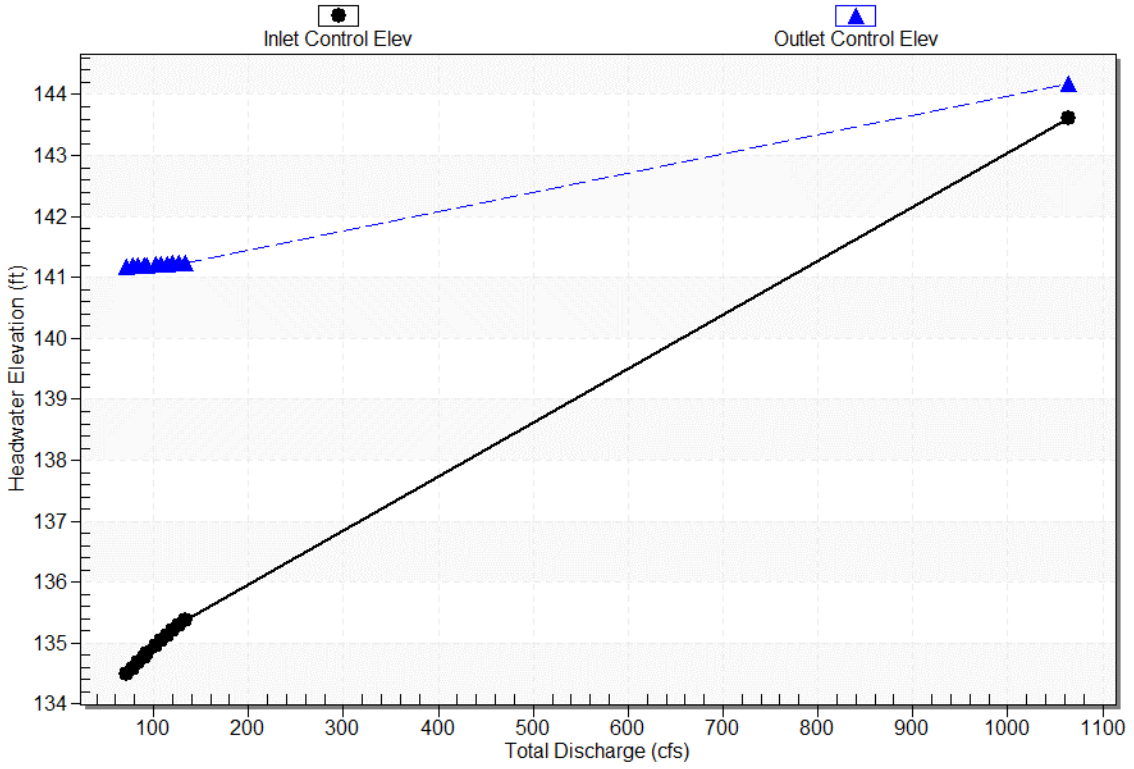

Water Surface Profile Plot for Culvert: 10.2ftx8.5ft

Crossing - CD 08 Post, Design Discharge - 93.4 cfs

Culvert - 10.2ftx8.5ft, Culvert Discharge - 93.4 cfs

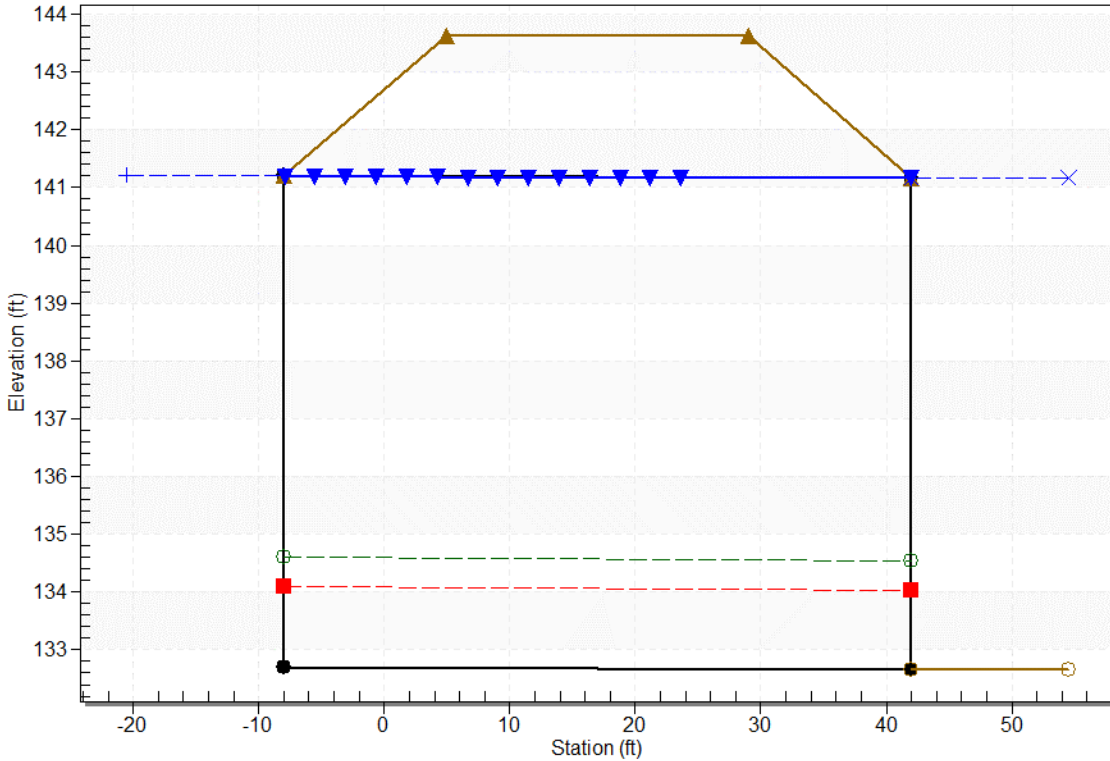

Site Data - 10.2ftx8.5ft

Site Data Option: Culvert Invert Data

Inlet Station: -8.00 ft

Inlet Elevation: 132.71 ft

Outlet Station: 42.00 ft

Outlet Elevation: 132.66 ft

Number of Barrels: 1

Culvert Data Summary - 10.2ftx8.5ft

Barrel Shape: Concrete Box

Barrel Span: 10.20 ft

Barrel Rise: 8.50 ft

Barrel Material: Concrete

Embedment: 0.00 in

Barrel Manning's n: 0.0120

Culvert Type: Straight

Inlet Configuration: Square Edge (30-75° flare) Wingwall (Ke=0.4)

Inlet Depression: None

Tailwater Data for Crossing: CD 08 Post

Table 4 - Downstream Channel Rating Curve (Crossing: CD 08 Post)

Flow (cfs)	Water Surface Elev (ft)	Depth (ft)
71.91	141.16	8.50
78.02	141.16	8.50
84.12	141.16	8.50
90.23	141.16	8.50
93.42	141.16	8.50
102.44	141.16	8.50
108.55	141.16	8.50
114.65	141.16	8.50
120.76	141.16	8.50
126.86	141.16	8.50
132.97	141.16	8.50

Tailwater Channel Data - CD 08 Post

Tailwater Channel Option: Enter Constant Tailwater Elevation

Constant Tailwater Elevation: 141.16 ft

Roadway Data for Crossing: CD 08 Post

Roadway Profile Shape: Constant Roadway Elevation

Crest Length: 50.00 ft

Crest Elevation: 143.62 ft

Roadway Surface: Paved

Roadway Top Width: 24.00 ft

Cross Drain
12

CD 12

CD 12 data was not found in an existing watershed model. The discharge rates are estimated based on the existing cross drain diameter per FDOT Drainage Design Guide Section 4.7.1 Method 1.

Based on the field visit, CD 12 has a 36" diameter.

Estimated discharges as follows:

i. 25 yr. $Q = AV$

where A = Existing Culvert Area

V = 6 feet per second (Confirm this value with the District Drainage Engineer; some districts use a lower velocity)

ii. 100 yr. $Q = 1.4 \times (25 \text{ yr } Q)$

iii. 500 yr. $Q = 1.7 \times (100 \text{ yr } Q)$

The 50 year design storm discharge rate was found using Figure B-1 below. A logarithmic trendline with an R-squared value equal to 1 was used to get the formula for the 50 year design storm discharge rate. Results are found in Table B-2.

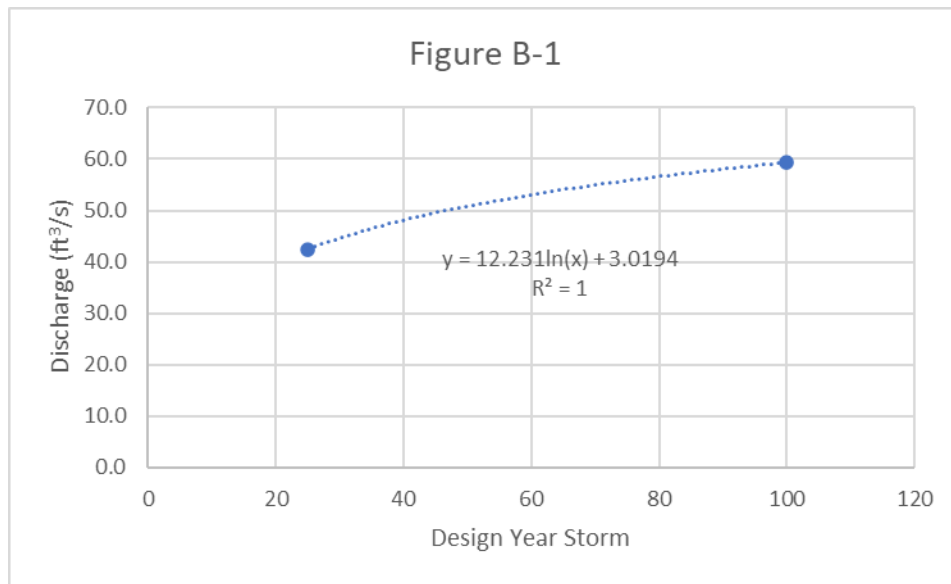

A	7.065
Q(25)	42.4
Q(50)	50.9
Q(100)	59.3
Q(500)	100.9

Table B-2

HY-8 Culvert Analysis Report

Crossing Discharge Data

Discharge Selection Method: Specify Minimum, Design, and Maximum Flow

Minimum Flow: 50.90 cfs

Design Flow: 59.30 cfs

Maximum Flow: 100.90 cfs

Table 1 - Summary of Culvert Flows at Crossing: CD 12 Pre

Headwater Elevation (ft)	Total Discharge (cfs)	36in pipe Discharge (cfs)	Roadway Discharge (cfs)	Iterations
151.26	50.90	50.90	0.00	1
151.48	55.90	53.94	1.40	60
151.49	59.30	54.00	4.93	5
151.49	65.90	54.07	11.33	4
151.50	70.90	54.12	16.55	4
151.50	75.90	54.16	21.29	3
151.50	80.90	54.20	26.30	3
151.51	85.90	54.24	31.36	3
151.51	90.90	54.28	36.41	3
151.51	95.90	54.31	41.43	3
151.51	100.90	54.34	46.45	3
151.48	53.90	53.90	0.00	Overtopping

Rating Curve Plot for Crossing: CD 12 Pre

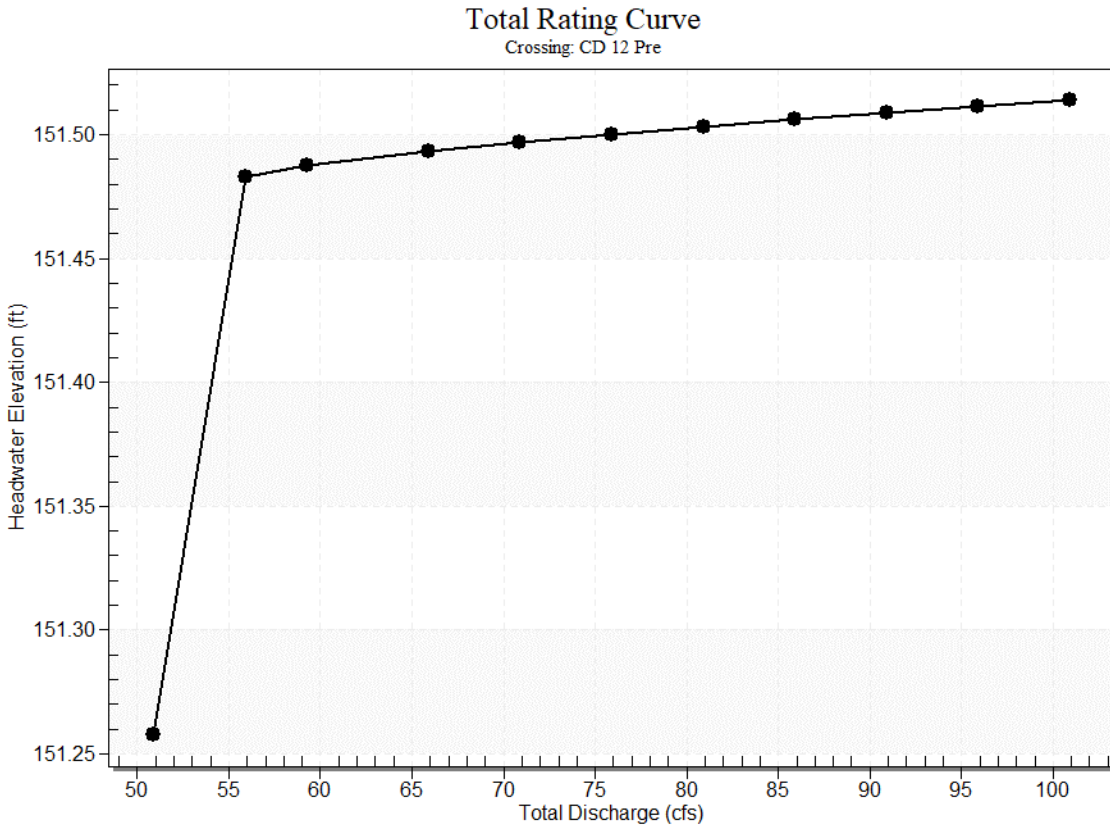

Culvert Data: 36in pipe

Table 1 - Culvert Summary Table: 36in pipe

Total Discharge (cfs)	Culvert Discharge (cfs)	Headwater Elevation (ft)	Inlet Control Depth (ft)	Outlet Control Depth (ft)	Flow Type	Normal Depth (ft)	Critical Depth (ft)	Outlet Depth (ft)	Tailwater Depth (ft)	Outlet Velocity (ft/s)	Tailwater Velocity (ft/s)
50.90 cfs	50.90 cfs	151.26	3.84	3.71	5-4	1.82	2.32	3.00	3.00	7.20	0.00
55.90 cfs	53.94 cfs	151.48	4.06	3.83	5-2	1.89	2.39	3.00	3.00	7.63	0.00
59.30 cfs	54.00 cfs	151.49	4.07	3.83	5-5	1.89	2.39	3.00	3.00	7.64	0.00
65.90 cfs	54.07 cfs	151.49	4.07	3.83	5-9	1.89	2.39	3.00	3.00	7.65	0.00
70.90 cfs	54.12 cfs	151.50	4.08	3.84	5-	1.90	2.39	3.00	3.00	7.66	0.00

cfs	cfs			1	JS1						
				f							
75.90	54.16	151.50	4.08	3.84	5-	1.90	2.39	3.00	3.00	7.66	0.00
cfs	cfs			3	JS1						
				f							
80.90	54.20	151.50	4.08	3.84	5-	1.90	2.39	3.00	3.00	7.67	0.00
cfs	cfs			5	JS1						
				f							
85.90	54.24	151.51	4.09	3.84	5-	1.90	2.39	3.00	3.00	7.67	0.00
cfs	cfs			7	JS1						
				f							
90.90	54.28	151.51	4.09	3.84	5-	1.90	2.39	3.00	3.00	7.68	0.00
cfs	cfs			9	JS1						
				f							
95.90	54.31	151.51	4.09	3.85	5-	1.90	2.39	3.00	3.00	7.68	0.00
cfs	cfs			1	JS1						
				f							
100.9	54.34	151.51	4.09	3.85	5-	1.90	2.39	3.00	3.00	7.69	0.00
0 cfs	cfs			2	JS1						
				f							

Culvert Barrel Data

Culvert Barrel Type Straight Culvert

Inlet Elevation (invert): 147.42 ft,

Outlet Elevation (invert): 146.89 ft

Culvert Length: 50.00 ft,

Culvert Slope: 0.0106

Culvert Performance Curve Plot: 36in pipe

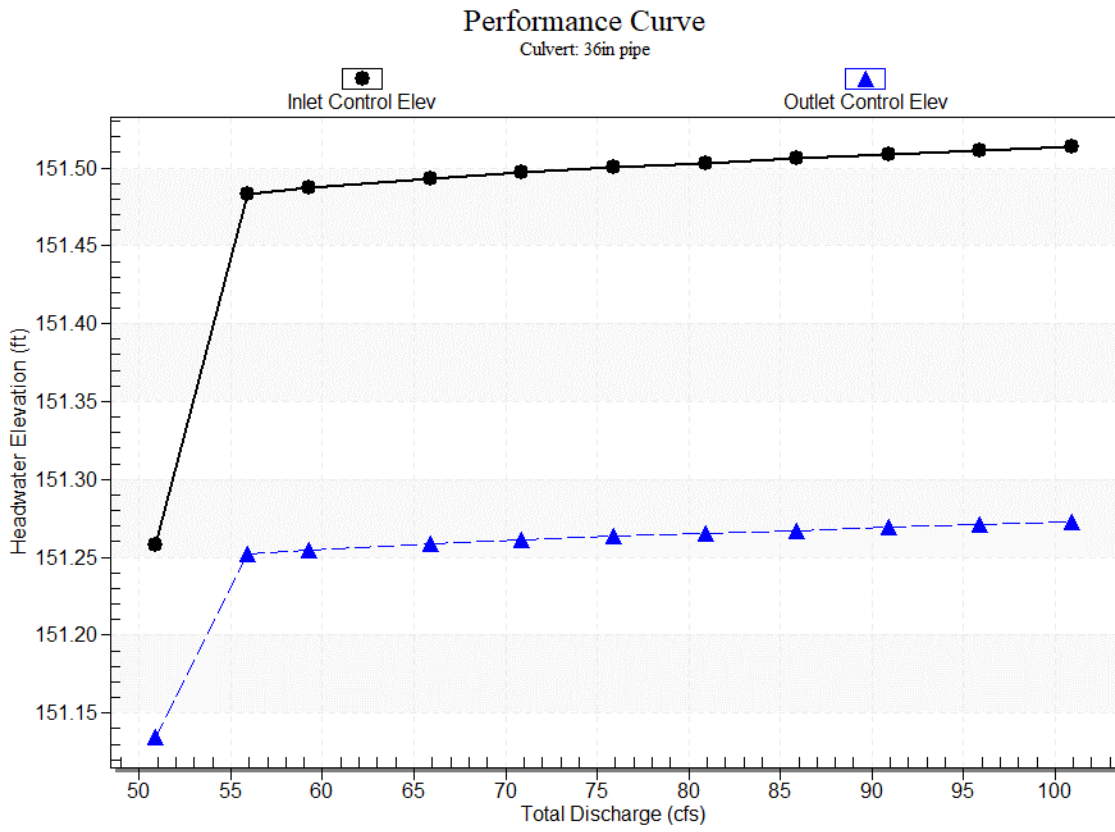

Water Surface Profile Plot for Culvert: 36in pipe

Crossing - CD 12 Pre, Design Discharge - 59.3 cfs

Culvert - 36in pipe, Culvert Discharge - 54.0 cfs

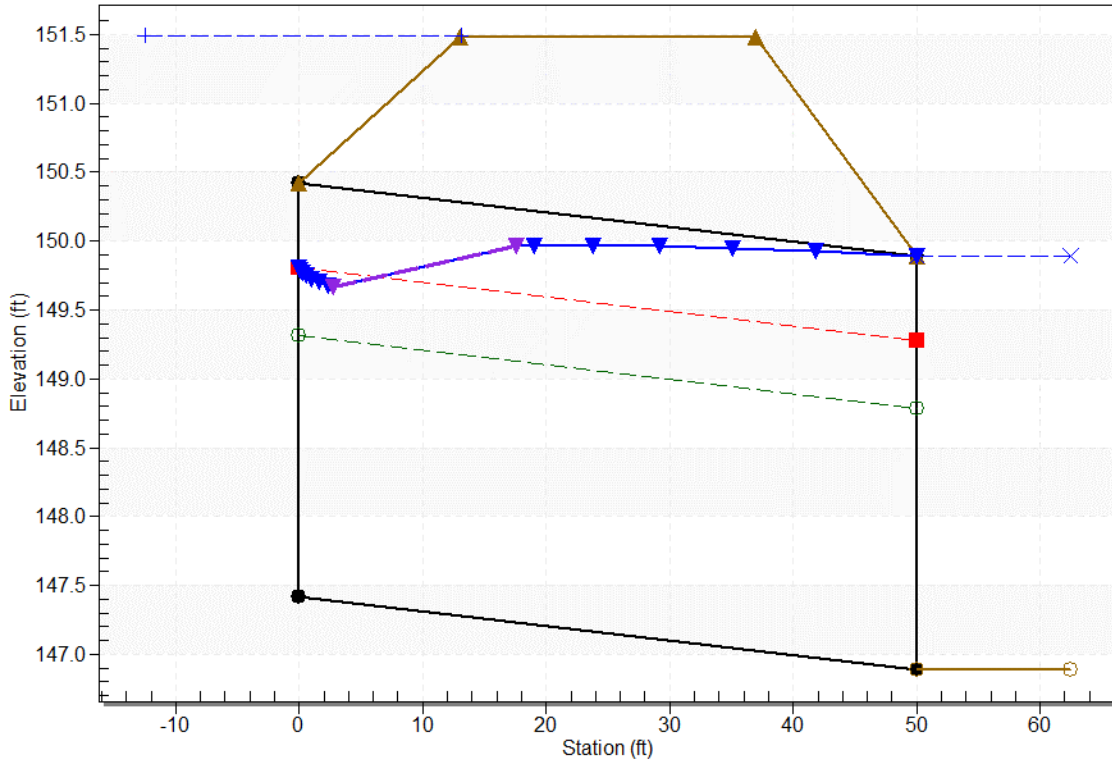

Site Data - 36in pipe

Site Data Option: Culvert Invert Data

Inlet Station: 0.00 ft

Inlet Elevation: 147.42 ft

Outlet Station: 50.00 ft

Outlet Elevation: 146.89 ft

Number of Barrels: 1

Culvert Data Summary - 36in pipe

Barrel Shape: Circular

Barrel Diameter: 3.00 ft

Barrel Material: Concrete

Embedment: 0.00 in

Barrel Manning's n: 0.0120

Culvert Type: Straight

Inlet Configuration: Beveled Edge (1:1) (Ke=0.2)

Inlet Depression: None

Tailwater Data for Crossing: CD 12 Pre

Table 2 - Downstream Channel Rating Curve (Crossing: CD 12 Pre)

Flow (cfs)	Water Surface Elev (ft)	Depth (ft)
50.90	149.89	3.00
55.90	149.89	3.00
59.30	149.89	3.00
65.90	149.89	3.00
70.90	149.89	3.00
75.90	149.89	3.00
80.90	149.89	3.00
85.90	149.89	3.00
90.90	149.89	3.00
95.90	149.89	3.00
100.90	149.89	3.00

Tailwater Channel Data - CD 12 Pre

Tailwater Channel Option: Enter Constant Tailwater Elevation

Constant Tailwater Elevation: 149.89 ft

Roadway Data for Crossing: CD 12 Pre

Roadway Profile Shape: Constant Roadway Elevation

Crest Length: 2560.00 ft

Crest Elevation: 151.48 ft

Roadway Surface: Paved

Roadway Top Width: 24.00 ft

Crossing Discharge Data

Discharge Selection Method: Specify Minimum, Design, and Maximum Flow

Minimum Flow: 50.90 cfs

Design Flow: 59.30 cfs

Maximum Flow: 100.90 cfs

Table 3 - Summary of Culvert Flows at Crossing: CD 12 Post

Headwater Elevation (ft)	Total Discharge (cfs)	42in pipe Discharge (cfs)	Roadway Discharge (cfs)	Iterations
150.84	50.90	50.90	0.00	1
151.06	55.90	55.90	0.00	1
151.22	59.30	59.30	0.00	1
151.48	65.90	64.85	0.41	78
151.49	70.90	64.98	5.35	5
151.49	75.90	65.07	10.39	4
151.50	80.90	65.15	15.52	4
151.50	85.90	65.21	20.21	3
151.50	90.90	65.27	25.21	3
151.51	95.90	65.33	30.26	3
151.51	100.90	65.38	35.29	3
151.48	64.80	64.80	0.00	Overtopping

Rating Curve Plot for Crossing: CD 12 Post

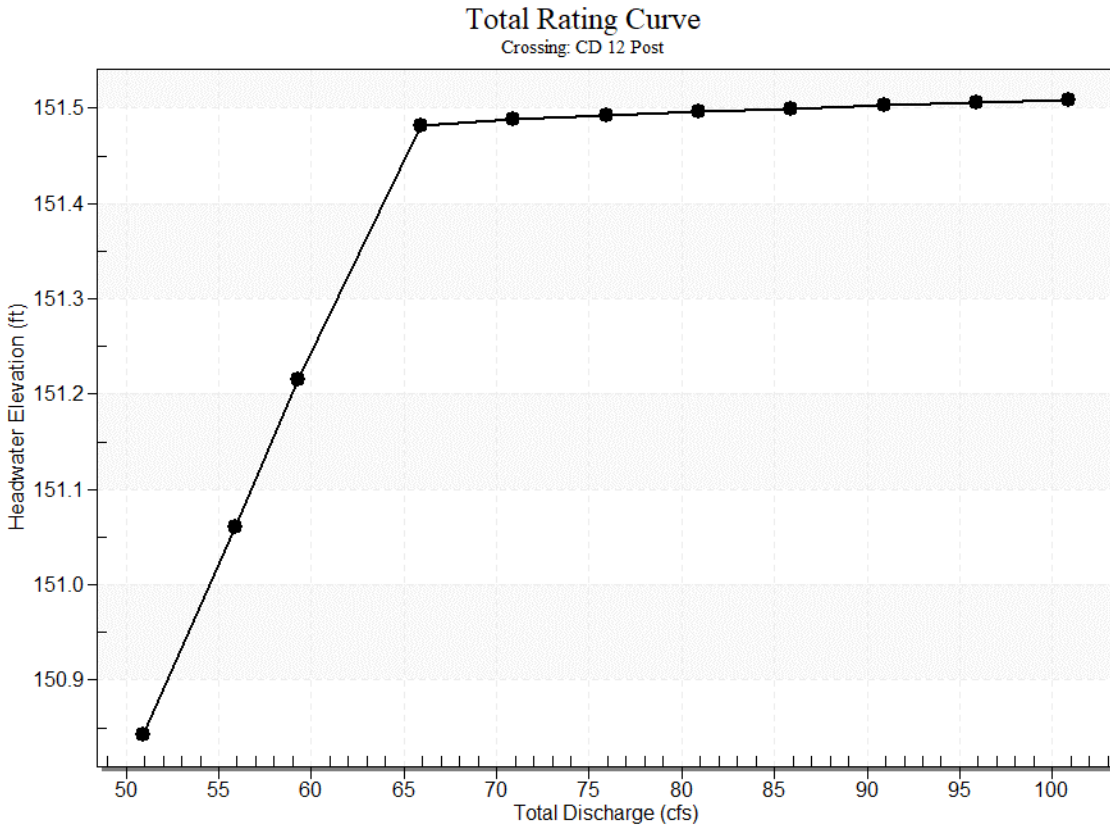

Culvert Data: 42in pipe

Table 2 - Culvert Summary Table: 42in pipe

Total Discharge (cfs)	Culvert Discharge (cfs)	Headwater Elevation (ft)	Inlet Control Depth (ft)	Outlet Control Depth (ft)	Flow Type	Normal Depth (ft)	Critical Depth (ft)	Outlet Depth (ft)	Tailwater Depth (ft)	Outlet Velocity (ft/s)	Tailwater Velocity (ft/s)
50.90 cfs	50.90 cfs	150.84	3.31	3.008	1-JS1t	1.65	2.23	3.00	3.00	5.80	0.00
55.90 cfs	55.90 cfs	151.06	3.52	3.143	5-S2n	1.74	2.34	1.90	3.00	10.50	0.00
59.30 cfs	59.30 cfs	151.22	3.68	3.241	5-S2n	1.81	2.41	1.96	3.00	10.67	0.00
65.90 cfs	64.85 cfs	151.48	3.95	3.415	5-S2n	1.91	2.52	2.07	3.00	10.92	0.00

70.90 cfs	64.98 cfs	151.49	3.95	3.42 0	5- S2 n	1.91	2.53	2.08	3.00	10.93	0.00
75.90 cfs	65.07 cfs	151.49	3.96	3.42 2	5- S2 n	1.91	2.53	2.08	3.00	10.93	0.00
80.90 cfs	65.15 cfs	151.50	3.96	3.42 5	5- S2 n	1.91	2.53	2.08	3.00	10.94	0.00
85.90 cfs	65.21 cfs	151.50	3.96	3.42 7	5- S2 n	1.91	2.53	2.08	3.00	10.94	0.00
90.90 cfs	65.27 cfs	151.50	3.97	3.42 9	5- S2 n	1.91	2.53	2.08	3.00	10.94	0.00
95.90 cfs	65.33 cfs	151.51	3.97	3.43 1	5- S2 n	1.92	2.53	2.08	3.00	10.94	0.00
100.9 0 cfs	65.38 cfs	151.51	3.97	3.43 3	5- S2 n	1.92	2.53	2.08	3.00	10.95	0.00

Culvert Barrel Data

Culvert Barrel Type Straight Culvert

Inlet Elevation (invert): 147.54 ft,

Outlet Elevation (invert): 146.89 ft

Culvert Length: 61.00 ft,

Culvert Slope: 0.0106

Culvert Performance Curve Plot: 42in pipe

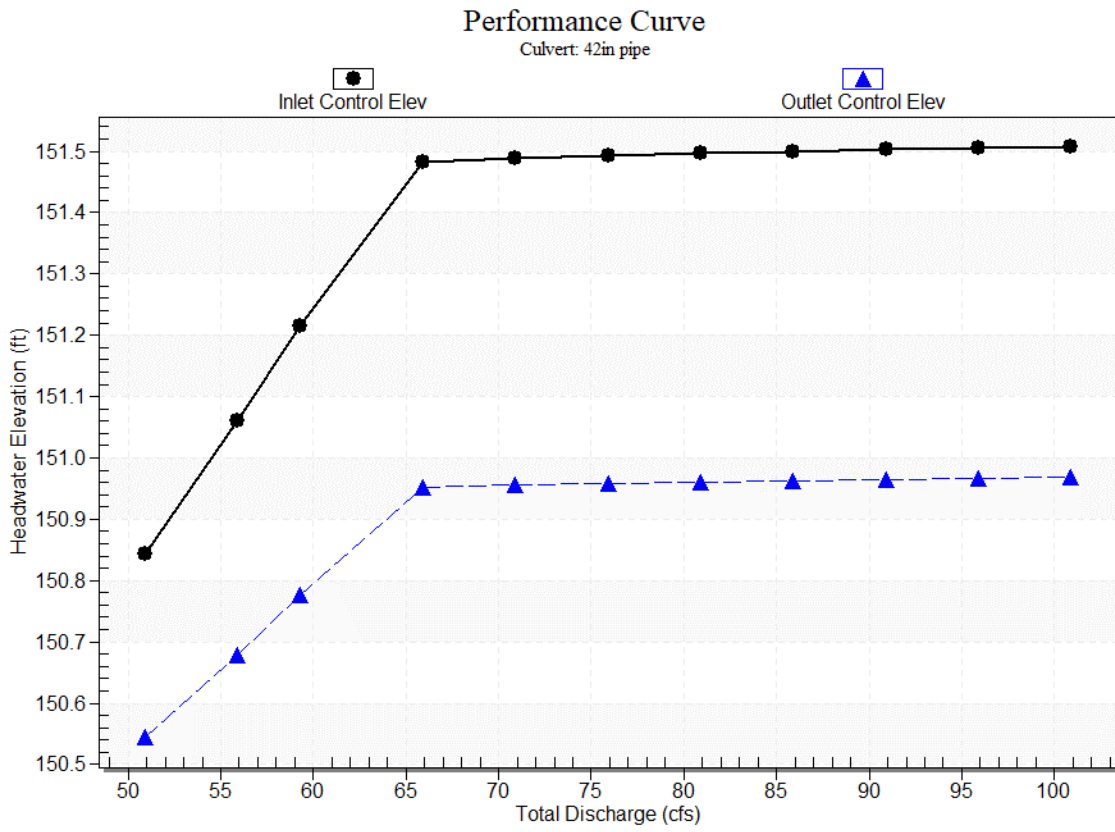

Water Surface Profile Plot for Culvert: 42in pipe

Crossing - CD 12 Post, Design Discharge - 59.3 cfs
Culvert - 42in pipe, Culvert Discharge - 59.3 cfs

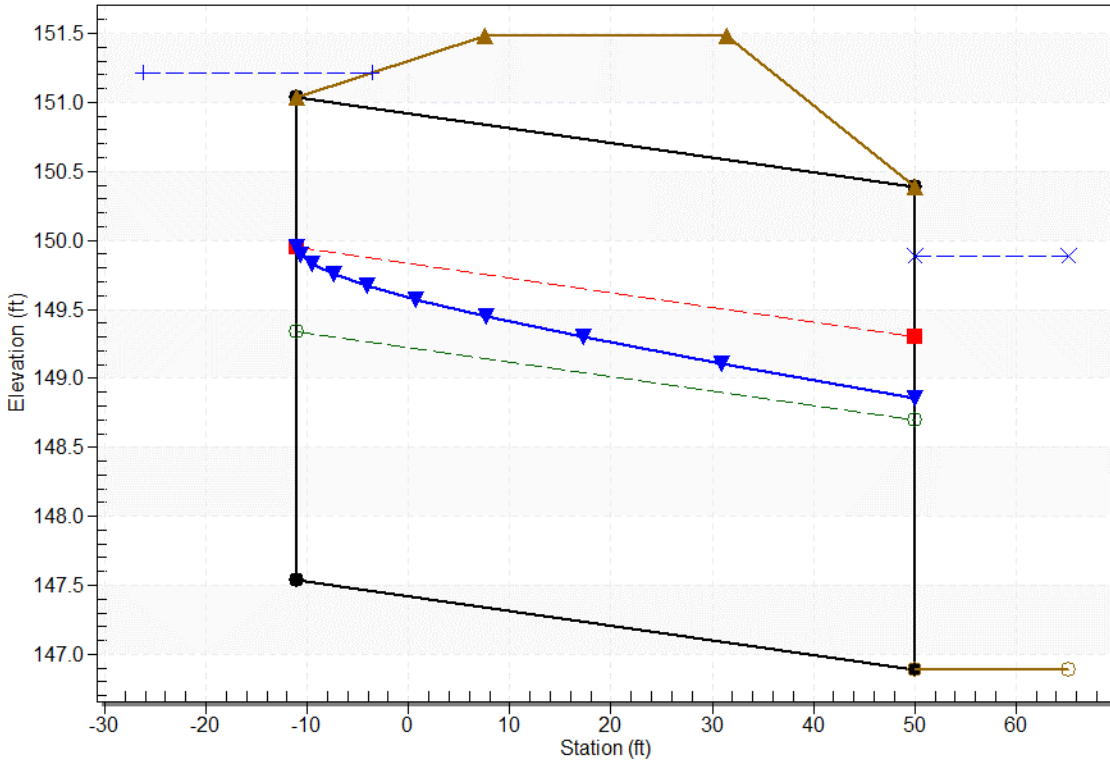

Site Data - 42in pipe

Site Data Option: Culvert Invert Data

Inlet Station: -11.00 ft

Inlet Elevation: 147.54 ft

Outlet Station: 50.00 ft

Outlet Elevation: 146.89 ft

Number of Barrels: 1

Culvert Data Summary - 42in pipe

Barrel Shape: Circular

Barrel Diameter: 3.50 ft

Barrel Material: Concrete

Embedment: 0.00 in

Barrel Manning's n: 0.0120

Culvert Type: Straight

Inlet Configuration: Beveled Edge (1:1) (Ke=0.2)

Inlet Depression: None

Tailwater Data for Crossing: CD 12 Post

Table 4 - Downstream Channel Rating Curve (Crossing: CD 12 Post)

Flow (cfs)	Water Surface Elev (ft)	Depth (ft)
50.90	149.89	3.00
55.90	149.89	3.00
59.30	149.89	3.00
65.90	149.89	3.00
70.90	149.89	3.00
75.90	149.89	3.00
80.90	149.89	3.00
85.90	149.89	3.00
90.90	149.89	3.00
95.90	149.89	3.00
100.90	149.89	3.00

Tailwater Channel Data - CD 12 Post

Tailwater Channel Option: Enter Constant Tailwater Elevation

Constant Tailwater Elevation: 149.89 ft

Roadway Data for Crossing: CD 12 Post

Roadway Profile Shape: Constant Roadway Elevation

Crest Length: 2560.00 ft

Crest Elevation: 151.48 ft

Roadway Surface: Paved

Roadway Top Width: 24.00 ft

Cross Drain

13

Pipe Link: RB0042B	Upstream	Downstream
Scenario: Icpr3	Invert: 130.20 ft	Invert: 130.00 ft
From Node: NB0042	Manning's N: 0.0120	Manning's N: 0.0120
To Node: NB0040	Geometry: Rectangular	Geometry: Rectangular
Link Count: 1	Max Depth: 3.00 ft	Max Depth: 3.00 ft
Flow Direction: Both	Max Width: 4.00 ft	Max Width: 4.00 ft
Damping: 0.0000 ft	Fillet: 0.00 ft	Fillet: 0.00 ft
Length: 35.00 ft	Bottom Clip	
FHWA Code: 10	Default: 0.00 ft	Default: 0.00 ft
Entr Loss Coef: 0.50	Op Table:	Op Table:
Exit Loss Coef: 1.00	Ref Node:	Ref Node:
Bend Loss Coef: 0.00	Manning's N: 0.0120	Manning's N: 0.0120
Bend Location: 0.00 dec	Top Clip	
Energy Switch: Energy	Default: 0.00 ft	Default: 0.00 ft
	Op Table:	Op Table:
	Ref Node:	Ref Node:
	Manning's N: 0.0120	Manning's N: 0.0120

Comment: Culvert Data Obtained from: PBSJ SURVEY 10/15/2010

Name	Group	Simulation	Max Time Flow hrs	Max Flow cfs	Max Delta Q cfs	Max Time US Stage hrs	Max US Stage ft	Max Time DS Stage hrs	Max DS Stage ft
RB0042B	B	PC100y1d	12.63	19.34	0.090	12.63	131.77	200.00	131.10
RB0042B	B	PC25y1d	12.62	15.74	0.072	12.62	131.54	200.00	130.90
RB0042B	B	PC50y1d	12.62	17.57	0.081	12.62	131.66	200.00	131.00

Name	Group	Simulation	Min Time Flow hrs	Min Flow cfs	Min Delta Q cfs	Min Time US Stage hrs	Min US Stage ft	Min Time DS Stage ft	Min DS Stage ft
RB0042B	B	PC100y1d	25.58	-0.08	0.000	0.00	130.20	1.41	130.03
RB0042B	B	PC25y1d	191.68	-0.05	0.000	0.00	130.20	1.73	130.03
RB0042B	B	PC50y1d	25.59	-0.06	0.000	0.00	130.20	1.55	130.03

HY-8 Culvert Analysis Report

Crossing Discharge Data

Discharge Selection Method: Specify Minimum, Design, and Maximum Flow

Minimum Flow: 17.57 cfs

Design Flow: 19.34 cfs

Maximum Flow: 32.88 cfs

Table 1 - Summary of Culvert Flows at Crossing: CD 13 Pre

Headwater Elevation (ft)	Total Discharge (cfs)	36inx48in Box Culvert Discharge (cfs)	Roadway Discharge (cfs)	Iterations
133.62	17.57	17.57	0.00	1
133.63	19.34	19.34	0.00	1
133.64	20.63	20.63	0.00	1
133.65	22.16	22.16	0.00	1
133.66	23.69	23.69	0.00	1
133.68	25.22	25.22	0.00	1
133.69	26.75	26.75	0.00	1
133.71	28.29	28.29	0.00	1
133.72	29.82	29.82	0.00	1
133.74	31.35	31.35	0.00	1
133.75	32.88	32.88	0.00	1
135.10	92.27	92.27	0.00	Overtopping

Rating Curve Plot for Crossing: CD 13 Pre

Total Rating Curve
Crossing: CD 13 Pre

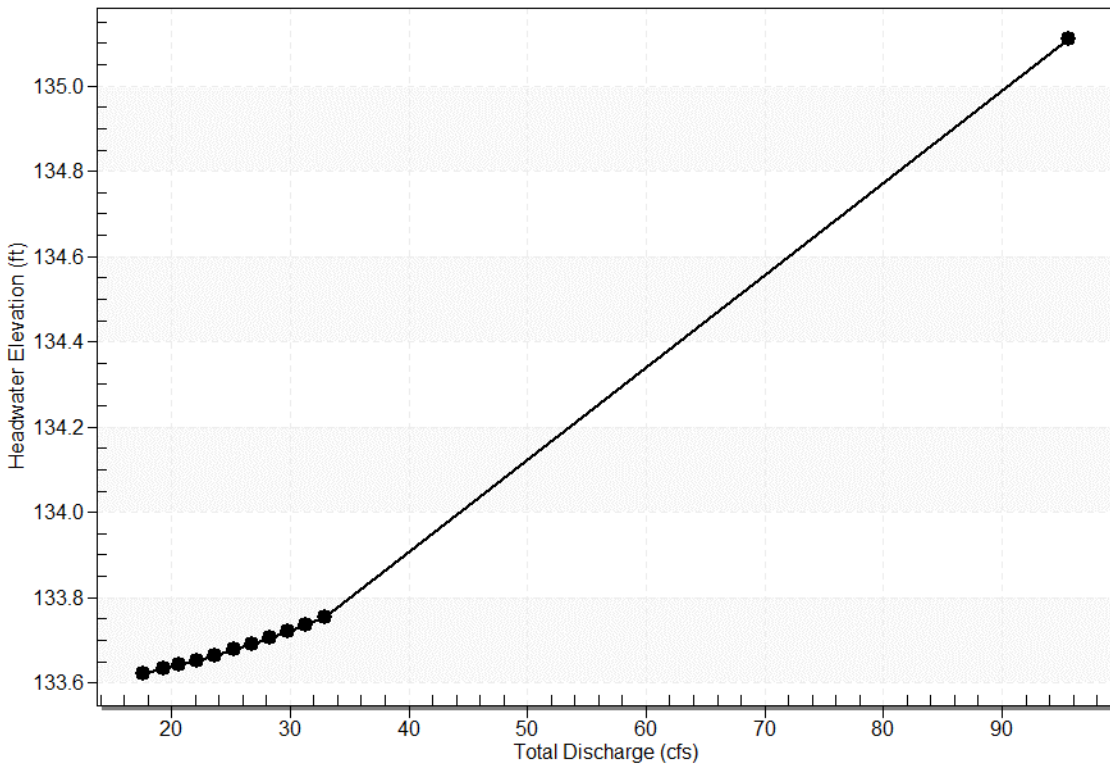

Culvert Data: 36inx48in Box Culvert

Table 1 - Culvert Summary Table: 36inx48in Box Culvert

Total Discharge (cfs)	Culvert Discharge (cfs)	Headwater Elevation (ft)	Inlet Control Depth (ft)	Outlet Control Depth (ft)	Flow Type	Normal Depth (ft)	Critical Depth (ft)	Outlet Depth (ft)	Tailwater Depth (ft)	Outlet Velocity (ft/s)	Tailwater Velocity (ft/s)
17.57 cfs	17.57 cfs	133.62	1.28	2.81	1-2	0.60	0.84	3.00	3.00	1.46	0.00
19.34 cfs	19.34 cfs	133.63	1.37	2.82	1-3	0.64	0.90	3.00	3.00	1.61	0.00
20.63 cfs	20.63 cfs	133.64	1.43	2.83	1-2	0.67	0.94	3.00	3.00	1.72	0.00
22.16 cfs	22.16 cfs	133.65	1.50	2.84	1-3	0.70	0.98	3.00	3.00	1.85	0.00
23.69 cfs	23.69 cfs	133.66	1.57	2.85	1-5	0.74	1.03	3.00	3.00	1.97	0.00
25.22 cfs	25.22 cfs	133.68	1.64	2.86	1-8	0.77	1.07	3.00	3.00	2.10	0.00

26.75 cfs	26.75 cfs	133.69	1.71	2.88 1	1- S1f	0.80	1.12	3.00	3.00	2.23	0.00
28.29 cfs	28.29 cfs	133.71	1.77	2.89 5	1- S1f	0.83	1.16	3.00	3.00	2.36	0.00
29.82 cfs	29.82 cfs	133.72	1.84	2.91 1	1- S1f	0.86	1.20	3.00	3.00	2.48	0.00
31.35 cfs	31.35 cfs	133.74	1.90	2.92 6	1- S1f	0.89	1.24	3.00	3.00	2.61	0.00
32.88 cfs	32.88 cfs	133.75	1.96	2.94 3	1- S1f	0.92	1.28	3.00	3.00	2.74	0.00

Culvert Barrel Data

Culvert Barrel Type Straight Culvert

Inlet Elevation (invert): 130.81 ft,

Outlet Elevation (invert): 130.57 ft

Culvert Length: 25.00 ft,

Culvert Slope: 0.0096

Culvert Performance Curve Plot: 36inx48in Box Culvert

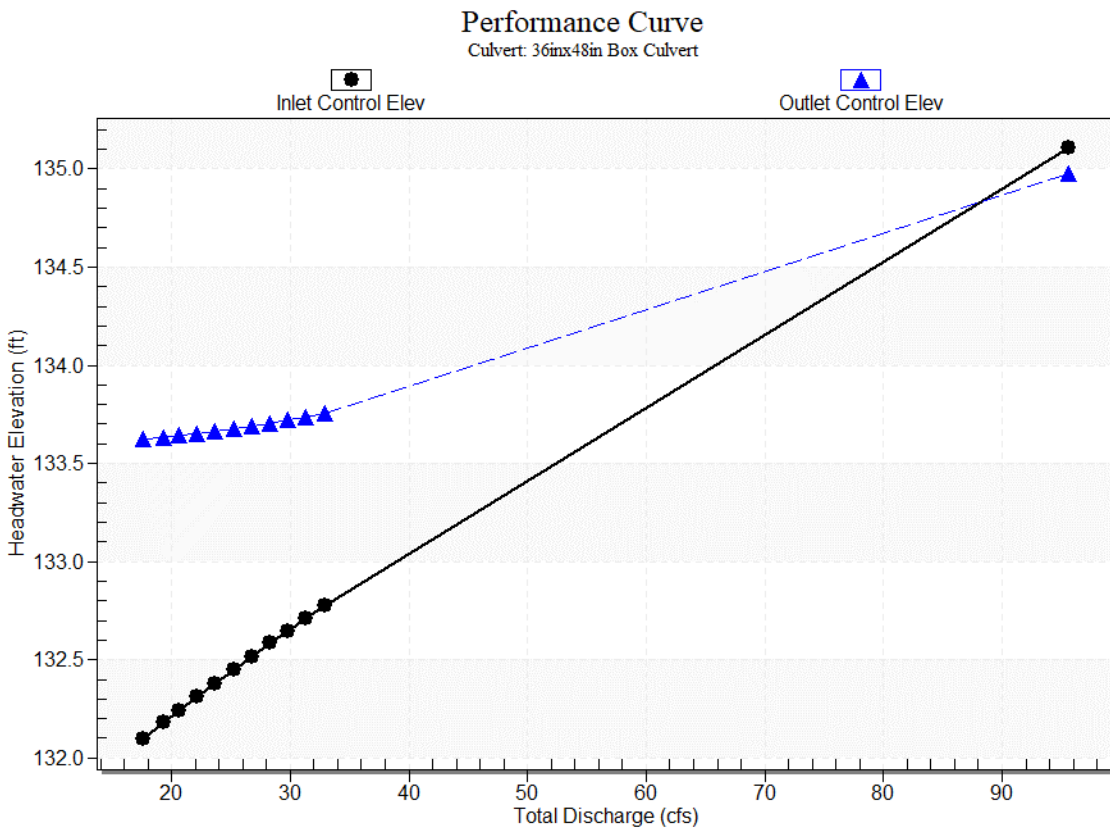

Water Surface Profile Plot for Culvert: 36inx48in Box Culvert

Crossing - CD 13 Pre, Design Discharge - 19.3 cfs

Culvert - 36inx48in Box Culvert, Culvert Discharge - 19.3 cfs

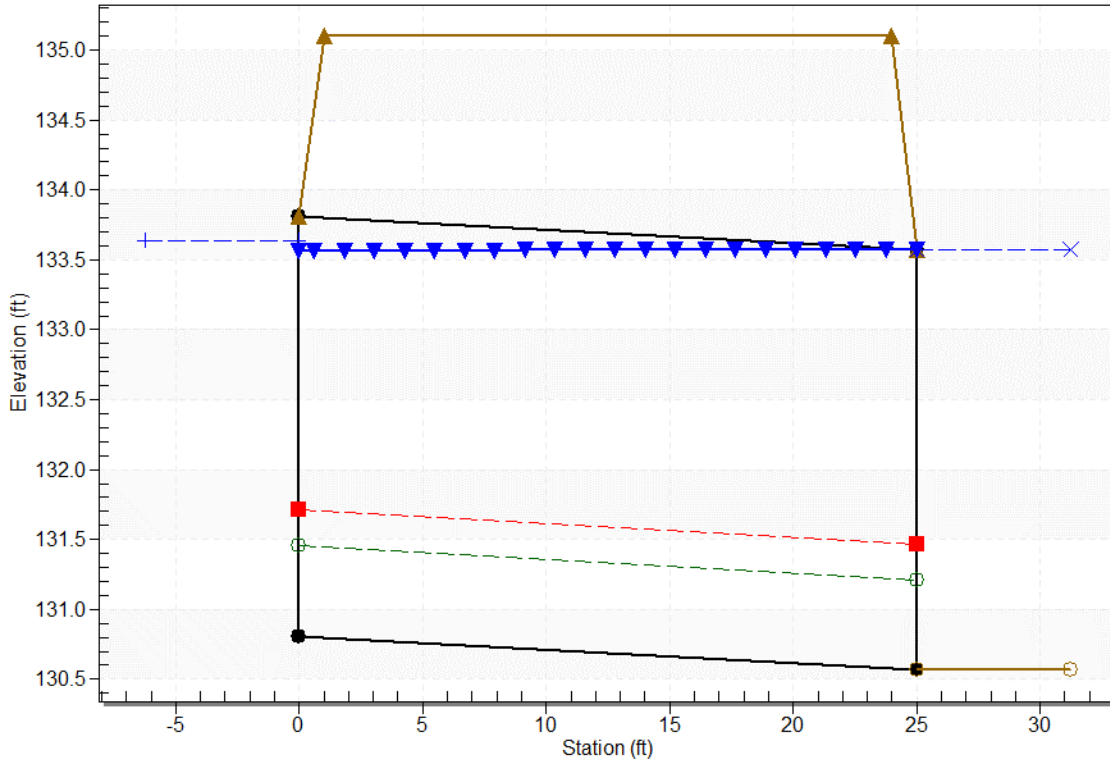

Site Data - 36inx48in Box Culvert

Site Data Option: Culvert Invert Data

Inlet Station: 0.00 ft

Inlet Elevation: 130.81 ft

Outlet Station: 25.00 ft

Outlet Elevation: 130.57 ft

Number of Barrels: 1

Culvert Data Summary - 36inx48in Box Culvert

Barrel Shape: Concrete Box

Barrel Span: 4.00 ft

Barrel Rise: 3.00 ft

Barrel Material: Concrete

Embedment: 0.00 in

Barrel Manning's n: 0.0120

Culvert Type: Straight

Inlet Configuration: Square Edge (30-75° flare) Wingwall (Ke=0.4)

Inlet Depression: None

Tailwater Data for Crossing: CD 13 Pre

Table 2 - Downstream Channel Rating Curve (Crossing: CD 13 Pre)

Flow (cfs)	Water Surface Elev (ft)	Depth (ft)
17.57	133.57	3.00
19.34	133.57	3.00
20.63	133.57	3.00
22.16	133.57	3.00
23.69	133.57	3.00
25.22	133.57	3.00
26.75	133.57	3.00
28.29	133.57	3.00
29.82	133.57	3.00
31.35	133.57	3.00
32.88	133.57	3.00

Tailwater Channel Data - CD 13 Pre

Tailwater Channel Option: Enter Constant Tailwater Elevation

Constant Tailwater Elevation: 133.57 ft

Roadway Data for Crossing: CD 13 Pre

Roadway Profile Shape: Constant Roadway Elevation

Crest Length: 1089.25 ft

Crest Elevation: 135.10 ft

Roadway Surface: Paved

Roadway Top Width: 23.00 ft

Crossing Discharge Data

Discharge Selection Method: Specify Minimum, Design, and Maximum Flow

Minimum Flow: 17.57 cfs

Design Flow: 19.34 cfs

Maximum Flow: 32.88 cfs

Table 3 - Summary of Culvert Flows at Crossing: CD 13 Post

Headwater Elevation (ft)	Total Discharge (cfs)	36inx48in Box Culvert Discharge (cfs)	Roadway Discharge (cfs)	Iterations
133.63	17.57	17.57	0.00	1
133.64	19.34	19.34	0.00	1
133.65	20.63	20.63	0.00	1
133.66	22.16	22.16	0.00	1
133.67	23.69	23.69	0.00	1
133.69	25.22	25.22	0.00	1
133.70	26.75	26.75	0.00	1
133.72	28.29	28.29	0.00	1
133.73	29.82	29.82	0.00	1
133.75	31.35	31.35	0.00	1
133.77	32.88	32.88	0.00	1
135.10	92.27	92.27	0.00	Overtopping

Rating Curve Plot for Crossing: CD 13 Post

Total Rating Curve
Crossing: CD 13 Post

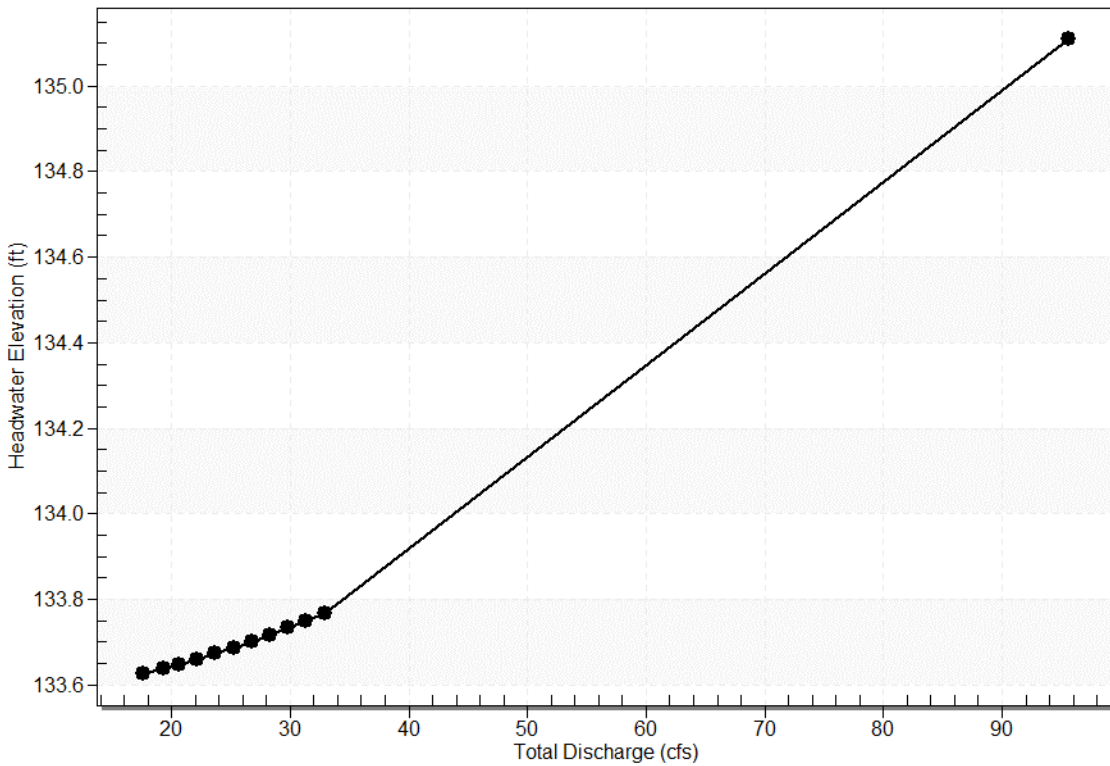

Culvert Data: 36inx48in Box Culvert

Table 2 - Culvert Summary Table: 36inx48in Box Culvert

Total Discharge (cfs)	Culvert Discharge (cfs)	Headwater Elevation (ft)	Inlet Control Depth (ft)	Outlet Control Depth (ft)	Flow Type	Normal Depth (ft)	Critical Depth (ft)	Outlet Depth (ft)	Tailwater Depth (ft)	Outlet Velocity (ft/s)	Tailwater Velocity (ft/s)
17.57 cfs	17.57 cfs	133.63	1.28	2.816	1-S1f	0.60	0.84	3.00	3.00	1.46	0.00
19.34 cfs	19.34 cfs	133.64	1.37	2.828	1-S1f	0.64	0.90	3.00	3.00	1.61	0.00
20.63 cfs	20.63 cfs	133.65	1.43	2.838	1-S1f	0.67	0.94	3.00	3.00	1.72	0.00
22.16 cfs	22.16 cfs	133.66	1.50	2.850	1-S1f	0.70	0.98	3.00	3.00	1.85	0.00
23.69 cfs	23.69 cfs	133.67	1.57	2.863	1-S1f	0.74	1.03	3.00	3.00	1.97	0.00
25.22 cfs	25.22 cfs	133.69	1.64	2.876	1-S1f	0.77	1.07	3.00	3.00	2.10	0.00

26.75 cfs	26.75 cfs	133.70	1.71	2.89 1	1- S1f	0.80	1.12	3.00	3.00	2.23	0.00
28.29 cfs	28.29 cfs	133.72	1.77	2.90 6	1- S1f	0.83	1.16	3.00	3.00	2.36	0.00
29.82 cfs	29.82 cfs	133.73	1.84	2.92 3	1- S1f	0.86	1.20	3.00	3.00	2.48	0.00
31.35 cfs	31.35 cfs	133.75	1.90	2.94 0	1- S1f	0.89	1.24	3.00	3.00	2.61	0.00
32.88 cfs	32.88 cfs	133.77	1.96	2.95 8	1- S1f	0.92	1.28	3.00	3.00	2.74	0.00

Culvert Barrel Data

Culvert Barrel Type Straight Culvert

Inlet Elevation (invert): 130.81 ft,

Outlet Elevation (invert): 130.33 ft

Culvert Length: 50.00 ft,

Culvert Slope: 0.0096

Culvert Performance Curve Plot: 36inx48in Box Culvert

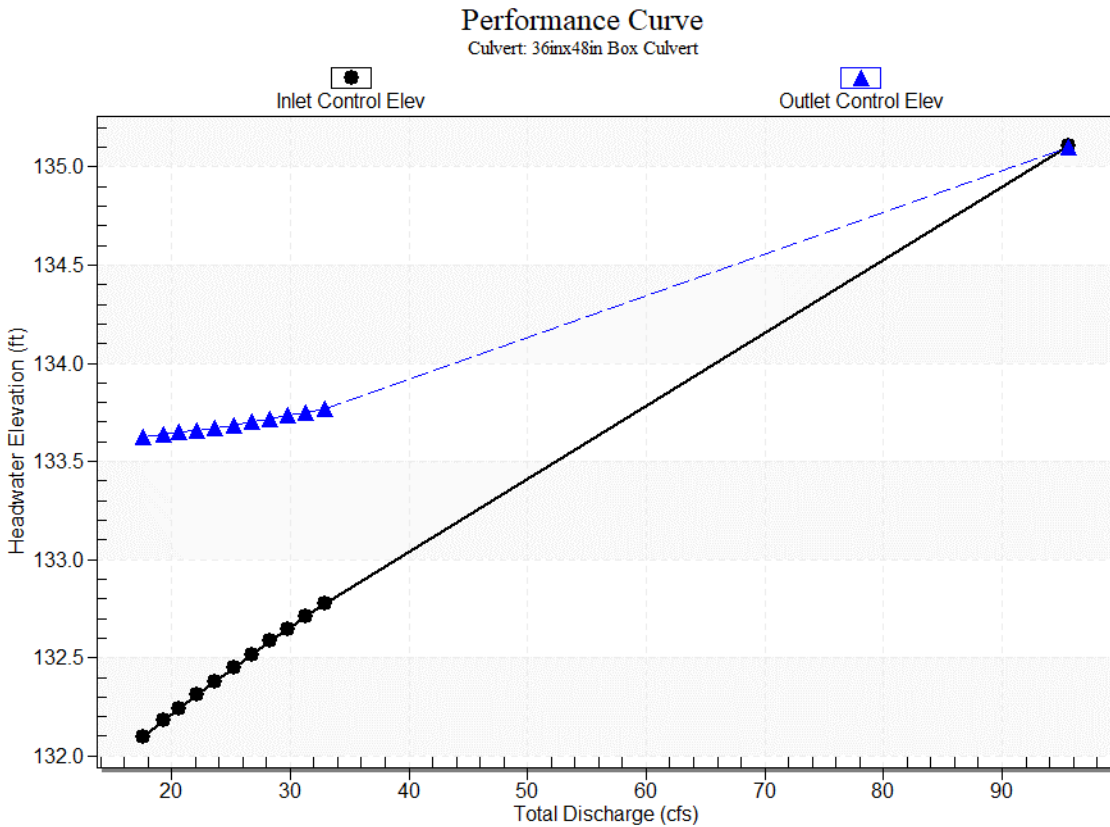

Water Surface Profile Plot for Culvert: 36inx48in Box Culvert

Crossing - CD 13 Post, Design Discharge - 19.3 cfs

Culvert - 36inx48in Box Culvert, Culvert Discharge - 19.3 cfs

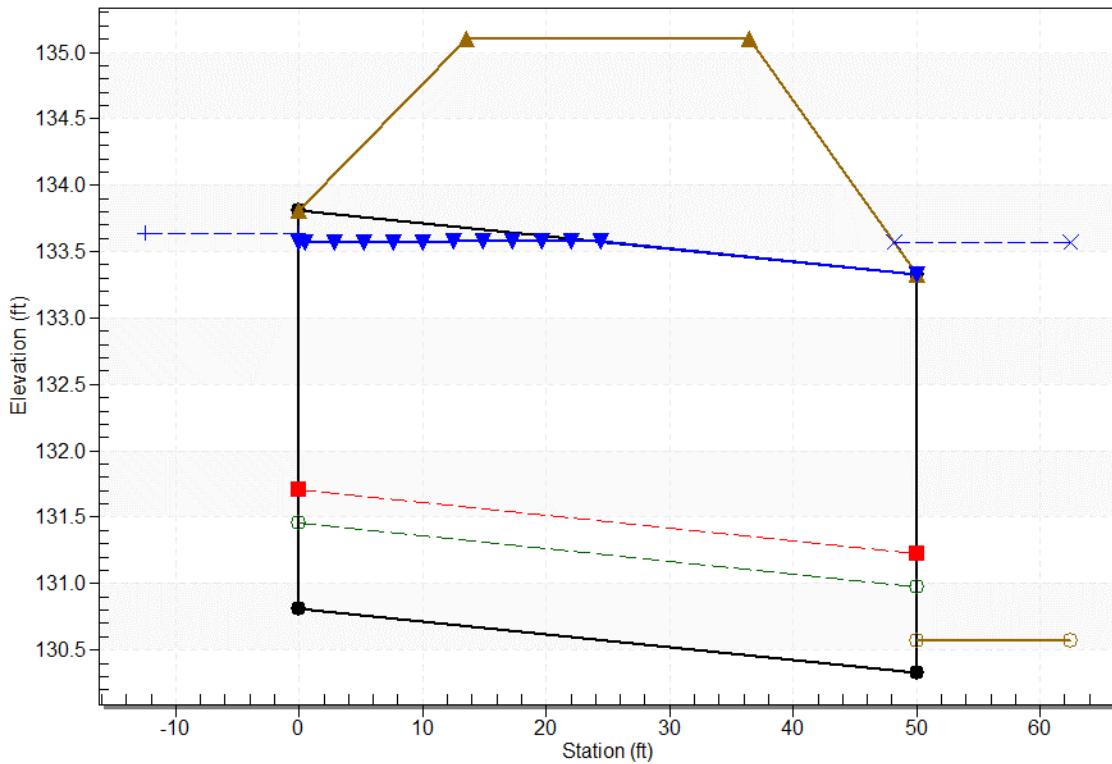

Site Data - 36inx48in Box Culvert

Site Data Option: Culvert Invert Data

Inlet Station: 0.00 ft

Inlet Elevation: 130.81 ft

Outlet Station: 50.00 ft

Outlet Elevation: 130.33 ft

Number of Barrels: 1

Culvert Data Summary - 36inx48in Box Culvert

Barrel Shape: Concrete Box

Barrel Span: 4.00 ft

Barrel Rise: 3.00 ft

Barrel Material: Concrete

Embedment: 0.00 in

Barrel Manning's n: 0.0120

Culvert Type: Straight

Inlet Configuration: Square Edge (30-75° flare) Wingwall (Ke=0.4)

Inlet Depression: None

Tailwater Data for Crossing: CD 13 Post

Table 4 - Downstream Channel Rating Curve (Crossing: CD 13 Post)

Flow (cfs)	Water Surface Elev (ft)	Depth (ft)
17.57	133.57	3.00
19.34	133.57	3.00
20.63	133.57	3.00
22.16	133.57	3.00
23.69	133.57	3.00
25.22	133.57	3.00
26.75	133.57	3.00
28.29	133.57	3.00
29.82	133.57	3.00
31.35	133.57	3.00
32.88	133.57	3.00

Tailwater Channel Data - CD 13 Post

Tailwater Channel Option: Enter Constant Tailwater Elevation

Constant Tailwater Elevation: 133.57 ft

Roadway Data for Crossing: CD 13 Post

Roadway Profile Shape: Constant Roadway Elevation

Crest Length: 1089.25 ft

Crest Elevation: 135.10 ft

Roadway Surface: Paved

Roadway Top Width: 23.00 ft

Cross Drain
16

CD 16

CD 16 is simulated in the Haines City Watershed Model. The discharge rates are based on the output from the Haines City Watershed Model. However, the 500 year design storm discharge rate is estimated using the FDOT Drainage Design Guide Section 4.7.1 Method 1. Results are found below in Table C-1.

Based on the field visit, the worst case scenario for the inlet configuration was assumed to have a Square Edge (90 °) Headwall.

Estimated discharges as follows:

i. 25 yr. $Q = AV$

where A = Existing Culvert Area

V = 6 feet per second (Confirm this value with the District Drainage Engineer; some districts use a lower velocity)

ii. 100 yr. $Q = 1.4 \times (25 \text{ yr } Q)$

iii. 500 yr. $Q = 1.7 \times (100 \text{ yr } Q)$

ICPR Output	Q (50)	78.31
ICPR Output	Q (100)	87.70
Estimated	Q (500)	149.09

Table C-1

Pipe Link: RB2210A	Upstream	Downstream
Scenario: HC_WMP	Invert: 122.39 ft	Invert: 122.09 ft
From Node: NB2210	Manning's N: 0.0130	Manning's N: 0.0130
To Node: NB0140	Geometry: Rectangular	Geometry: Rectangular
Link Count: 1	Max Depth: 6.00 ft	Max Depth: 6.00 ft
Flow Direction: Both	Max Width: 6.00 ft	Max Width: 6.00 ft
Damping: 0.0000 ft	Fillet: 0.00 ft	Fillet: 0.00 ft
Length: 125.00 ft	Bottom Clip	
FHWA Code: 0	Default: 0.00 ft	Default: 0.00 ft
Entr Loss Coef: 0.40	Op Table:	Op Table:
Exit Loss Coef: 0.00	Ref Node:	Ref Node:
Bend Loss Coef: 0.00	Manning's N: 0.0000	Manning's N: 0.0000
Bend Location: 0.00 dec	Top Clip	
Energy Switch: Energy	Default: 0.00 ft	Default: 0.00 ft
	Op Table:	Op Table:
	Ref Node:	Ref Node:
	Manning's N: 0.0000	Manning's N: 0.0000

Comment: Imported from Peace Creek 2.

Sim	Link Name	Maximum Flow Rate [cfs]	Time to Maximum Flow Rate [hrs]	Minimum Flow Rate [cfs]	Time to Minimum Flow Rate [hrs]
100yr24hr	RB2210A	87.70	36.0200	-44.18	13.3145
50yr24hr	RB2210A	78.31	31.0020	-51.84	12.9479

HY-8 Culvert Analysis Report

Crossing Discharge Data

Discharge Selection Method: Specify Minimum, Design, and Maximum Flow

Minimum Flow: 78.31 cfs

Design Flow: 87.70 cfs

Maximum Flow: 149.09 cfs

Table 1 - Summary of Culvert Flows at Crossing: CD 16 Pre

Headwater Elevation (ft)	Total Discharge (cfs)	72inx72in Box Culvert Discharge (cfs)	Roadway Discharge (cfs)	Iterations
128.25	78.31	78.31	0.00	1
128.30	87.70	87.70	0.00	1
128.33	92.47	92.47	0.00	1
128.37	99.54	99.54	0.00	1
128.42	106.62	106.62	0.00	1
128.47	113.70	113.70	0.00	1
128.53	120.78	120.78	0.00	1
128.59	127.86	127.86	0.00	1
128.65	134.93	134.93	0.00	1
128.71	142.01	142.01	0.00	1
128.78	149.09	149.09	0.00	1
133.25	446.37	446.37	0.00	Overtopping

Rating Curve Plot for Crossing: CD 16 Pre

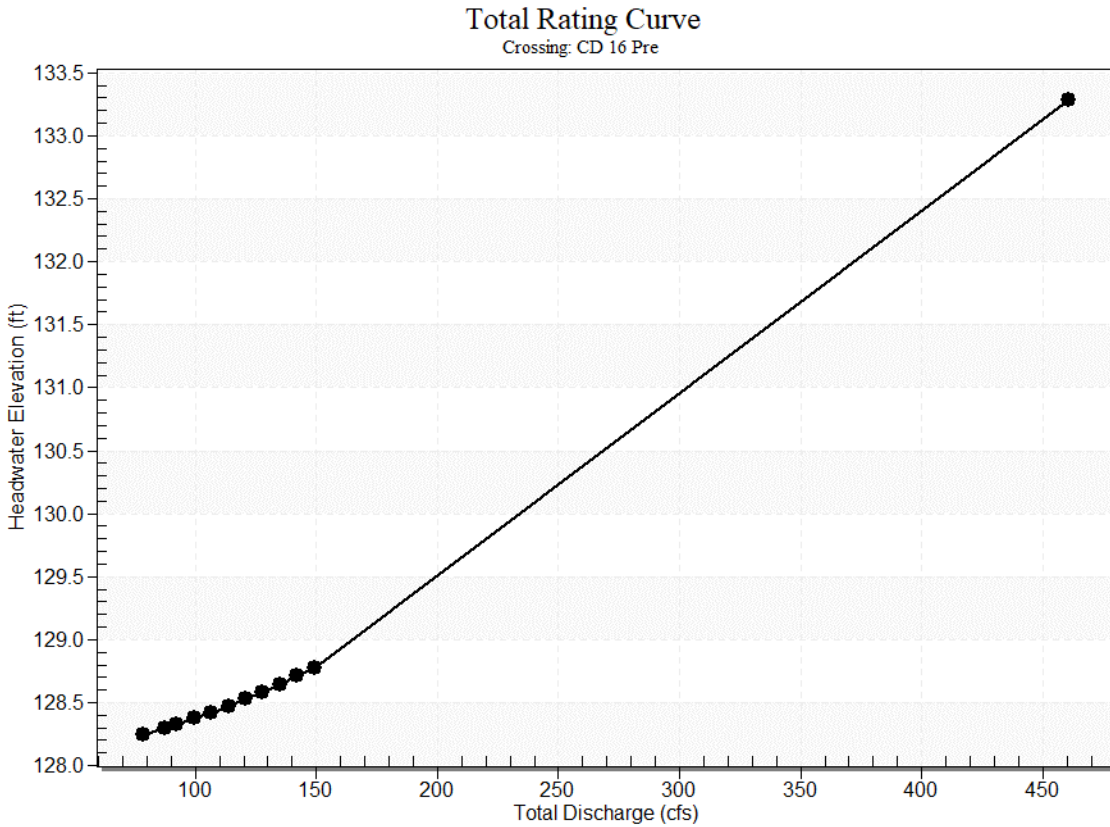

Culvert Data: 72inx72in Box Culvert

Table 1 - Culvert Summary Table: 72inx72in Box Culvert

Total Discharge (cfs)	Culvert Discharge (cfs)	Headwater Elevation (ft)	Inlet Control Depth (ft)	Outlet Control Depth (ft)	Flow Type	Normal Depth (ft)	Critical Depth (ft)	Outlet Depth (ft)	Tailwater Depth (ft)	Outlet Velocity (ft/s)	Tailwater Velocity (ft/s)
78.31 cfs	78.31 cfs	128.25	2.99	5.858	3-M1f	2.04	1.74	6.00	6.00	2.18	0.00
87.70 cfs	87.70 cfs	128.30	3.21	5.910	3-M1f	2.22	1.88	6.00	6.00	2.44	0.00
92.47 cfs	92.47 cfs	128.33	3.32	5.939	3-M1f	2.30	1.95	6.00	6.00	2.57	0.00
99.54 cfs	99.54 cfs	128.37	3.49	5.984	3-M1f	2.43	2.04	6.00	6.00	2.77	0.00

106.6 2 cfs	106.62 cfs	128.42	3.64	6.03 2	3- M1 f	2.55	2.14	6.00	6.00	2.96	0.00
113.7 0 cfs	113.70 cfs	128.47	3.80	6.08 4	3- M1 f	2.68	2.23	6.00	6.00	3.16	0.00
120.7 8 cfs	120.78 cfs	128.53	3.95	6.13 8	3- M1 f	2.80	2.33	6.00	6.00	3.35	0.00
127.8 6 cfs	127.86 cfs	128.59	4.10	6.19 6	3- M1 f	2.92	2.42	6.00	6.00	3.55	0.00
134.9 3 cfs	134.93 cfs	128.65	4.24	6.25 7	3- M1 f	3.04	2.50	6.00	6.00	3.75	0.00
142.0 1 cfs	142.01 cfs	128.71	4.39	6.32 1	3- M1 f	3.16	2.59	6.00	6.00	3.94	0.00
149.0 9 cfs	149.09 cfs	128.78	4.53	6.38 8	3- M1 f	3.28	2.68	6.00	6.00	4.14	0.00

Culvert Barrel Data

Culvert Barrel Type Straight Culvert

Inlet Elevation (invert): 122.39 ft,

Outlet Elevation (invert): 122.09 ft

Culvert Length: 125.00 ft,

Culvert Slope: 0.0024

Culvert Performance Curve Plot: 72inx72in Box Culvert

Performance Curve Culvert: 72inx72in Box Culvert

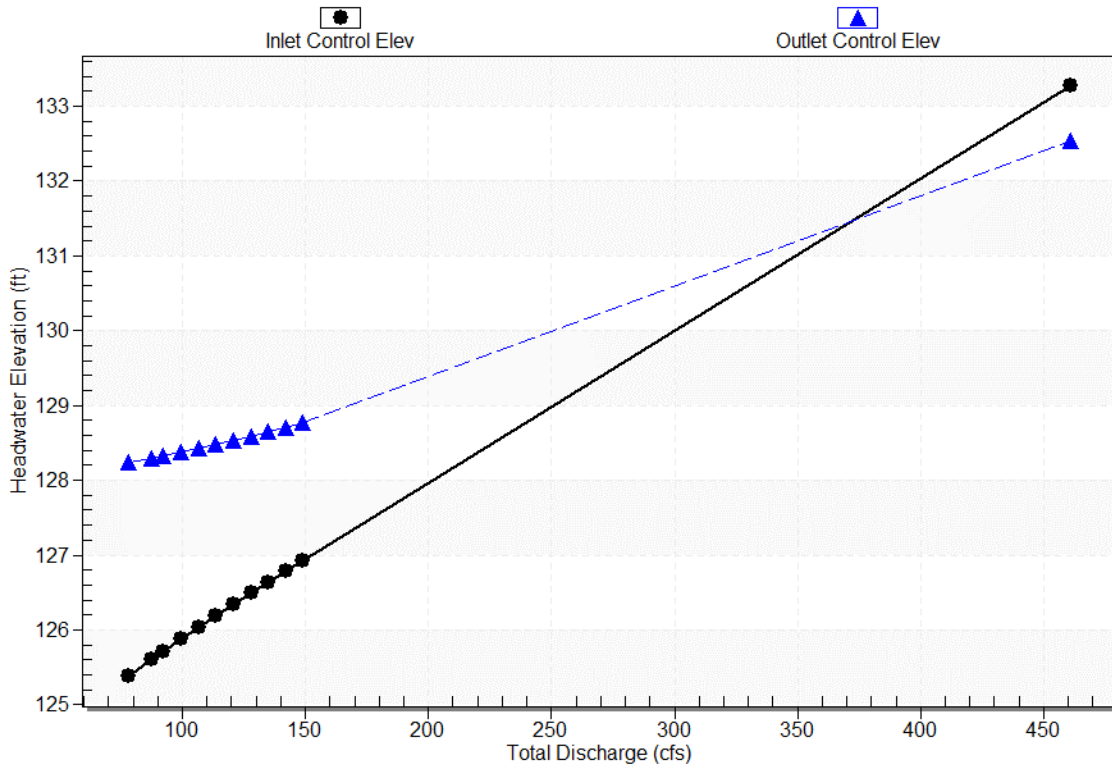

Water Surface Profile Plot for Culvert: 72inx72in Box Culvert

Crossing - CD 16 Pre , Design Discharge - 87.7 cfs

Culvert - 72inx72in Box Culvert, Culvert Discharge - 87.7 cfs

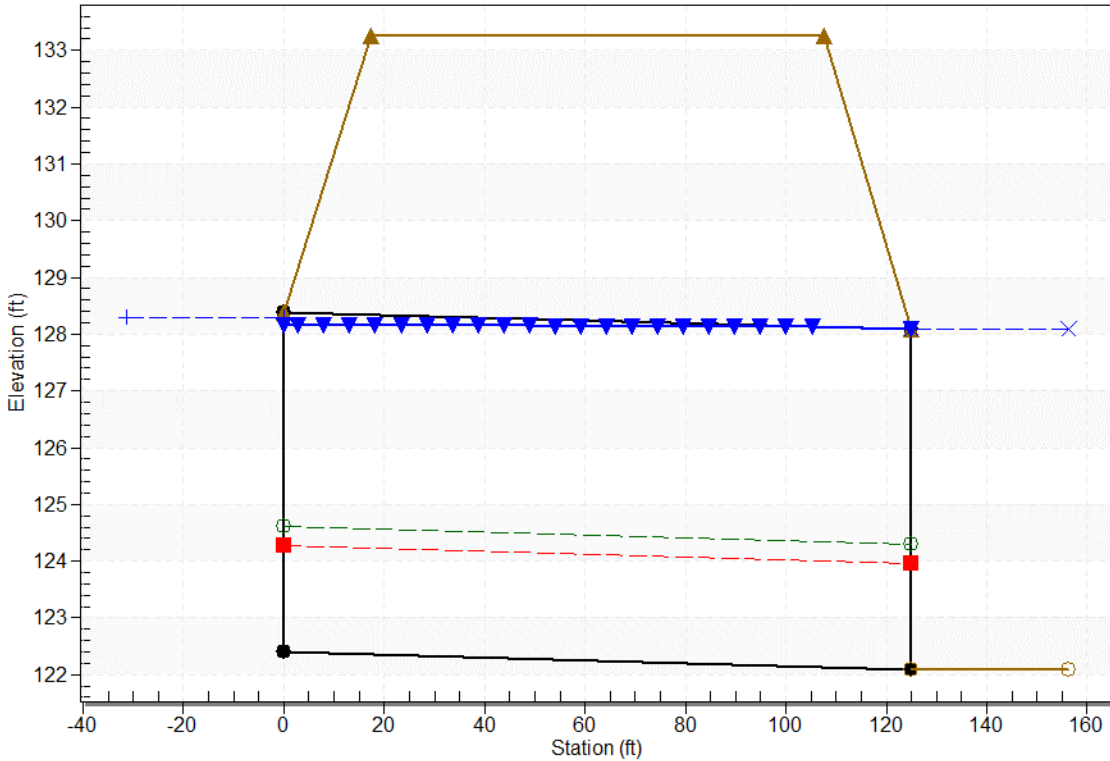

Site Data - 72inx72in Box Culvert

Site Data Option: Culvert Invert Data

Inlet Station: 0.00 ft

Inlet Elevation: 122.39 ft

Outlet Station: 125.00 ft

Outlet Elevation: 122.09 ft

Number of Barrels: 1

Culvert Data Summary - 72inx72in Box Culvert

Barrel Shape: Concrete Box

Barrel Span: 6.00 ft

Barrel Rise: 6.00 ft

Barrel Material: Concrete

Embedment: 0.00 in

Barrel Manning's n: 0.0130

Culvert Type: Straight

Inlet Configuration: Square Edge (90°) Headwall

Inlet Depression: None

Tailwater Data for Crossing: CD 16 Pre

Table 2 - Downstream Channel Rating Curve (Crossing: CD 16 Pre)

Flow (cfs)	Water Surface Elev (ft)	Depth (ft)
78.31	128.09	6.00
87.70	128.09	6.00
92.47	128.09	6.00
99.54	128.09	6.00
106.62	128.09	6.00
113.70	128.09	6.00
120.78	128.09	6.00
127.86	128.09	6.00
134.93	128.09	6.00
142.01	128.09	6.00
149.09	128.09	6.00

Tailwater Channel Data - CD 16 Pre

Tailwater Channel Option: Enter Constant Tailwater Elevation

Constant Tailwater Elevation: 128.09 ft

Roadway Data for Crossing: CD 16 Pre

Roadway Profile Shape: Constant Roadway Elevation

Crest Length: 793.00 ft

Crest Elevation: 133.25 ft

Roadway Surface: Paved

Roadway Top Width: 90.00 ft

Crossing Discharge Data

Discharge Selection Method: Specify Minimum, Design, and Maximum Flow

Minimum Flow: 78.31 cfs

Design Flow: 87.70 cfs

Maximum Flow: 149.09 cfs

Table 3 - Summary of Culvert Flows at Crossing: CD 16 Post

Headwater Elevation (ft)	Total Discharge (cfs)	72inx72in Box Culvert Discharge (cfs)	Roadway Discharge (cfs)	Iterations
128.23	78.31	78.31	0.00	1
128.26	87.70	87.70	0.00	1
128.28	92.47	92.47	0.00	1
128.31	99.54	99.54	0.00	1
128.34	106.62	106.62	0.00	1
128.38	113.70	113.70	0.00	1
128.41	120.78	120.78	0.00	1
128.45	127.86	127.86	0.00	1
128.49	134.93	134.93	0.00	1
128.54	142.01	142.01	0.00	1
128.58	149.09	149.09	0.00	1
133.25	446.37	446.37	0.00	Overtopping

Rating Curve Plot for Crossing: CD 16 Post

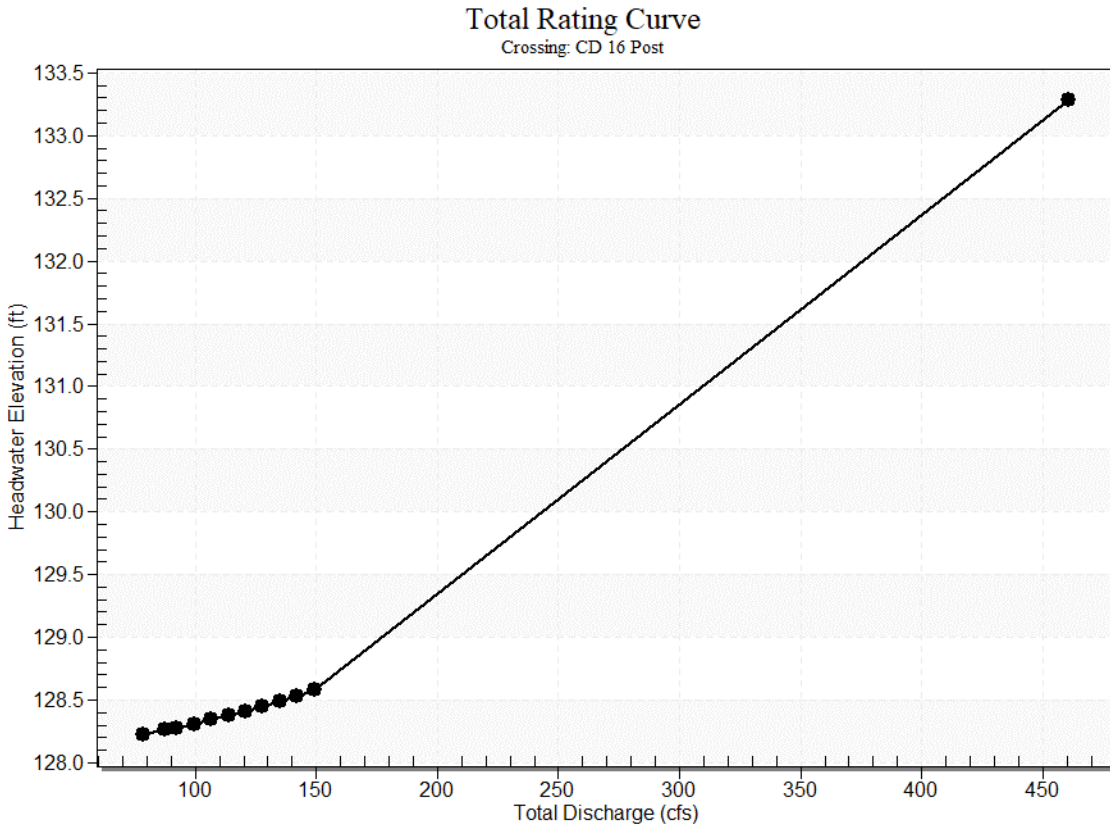

Culvert Data: 72inx72in Box Culvert

Table 2 - Culvert Summary Table: 72inx72in Box Culvert

Total Discharge (cfs)	Culvert Discharge (cfs)	Headwater Elevation (ft)	Inlet Control Depth (ft)	Outlet Control Depth (ft)	Flow Type	Normal Depth (ft)	Critical Depth (ft)	Outlet Depth (ft)	Tailwater Depth (ft)	Outlet Velocity (ft/s)	Tailwater Velocity (ft/s)
78.31 cfs	78.31 cfs	128.23	2.99	5.836	3-M1f	2.03	1.74	6.00	6.03	2.18	0.00
87.70 cfs	87.70 cfs	128.26	3.21	5.870	3-M1f	2.21	1.88	6.00	6.03	2.44	0.00
92.47 cfs	92.47 cfs	128.28	3.32	5.889	3-M1f	2.29	1.95	6.00	6.03	2.57	0.00
99.54 cfs	99.54 cfs	128.31	3.49	5.919	3-M1f	2.42	2.04	6.00	6.03	2.77	0.00

106.6 2 cfs	106.62 cfs	128.34	3.64	5.95 1	3- M1 f	2.54	2.14	6.00	6.03	2.96	0.00
113.7 0 cfs	113.70 cfs	128.38	3.80	5.98 6	3- M1 f	2.67	2.23	6.00	6.03	3.16	0.00
120.7 8 cfs	120.78 cfs	128.41	3.95	6.02 2	3- M1 f	2.79	2.33	6.00	6.03	3.35	0.00
127.8 6 cfs	127.86 cfs	128.45	4.10	6.06 1	3- M1 f	2.91	2.42	6.00	6.03	3.55	0.00
134.9 3 cfs	134.93 cfs	128.49	4.24	6.10 2	3- M1 f	3.03	2.50	6.00	6.03	3.75	0.00
142.0 1 cfs	142.01 cfs	128.54	4.39	6.14 5	3- M1 f	3.15	2.59	6.00	6.03	3.94	0.00
149.0 9 cfs	149.09 cfs	128.58	4.53	6.19 1	3- M1 f	3.27	2.68	6.00	6.03	4.14	0.00

Culvert Barrel Data

Culvert Barrel Type Straight Culvert

Inlet Elevation (invert): 122.39 ft,

Outlet Elevation (invert): 122.06 ft

Culvert Length: 136.00 ft,

Culvert Slope: 0.0024

Culvert Performance Curve Plot: 72inx72in Box Culvert

Performance Curve Culvert: 72inx72in Box Culvert

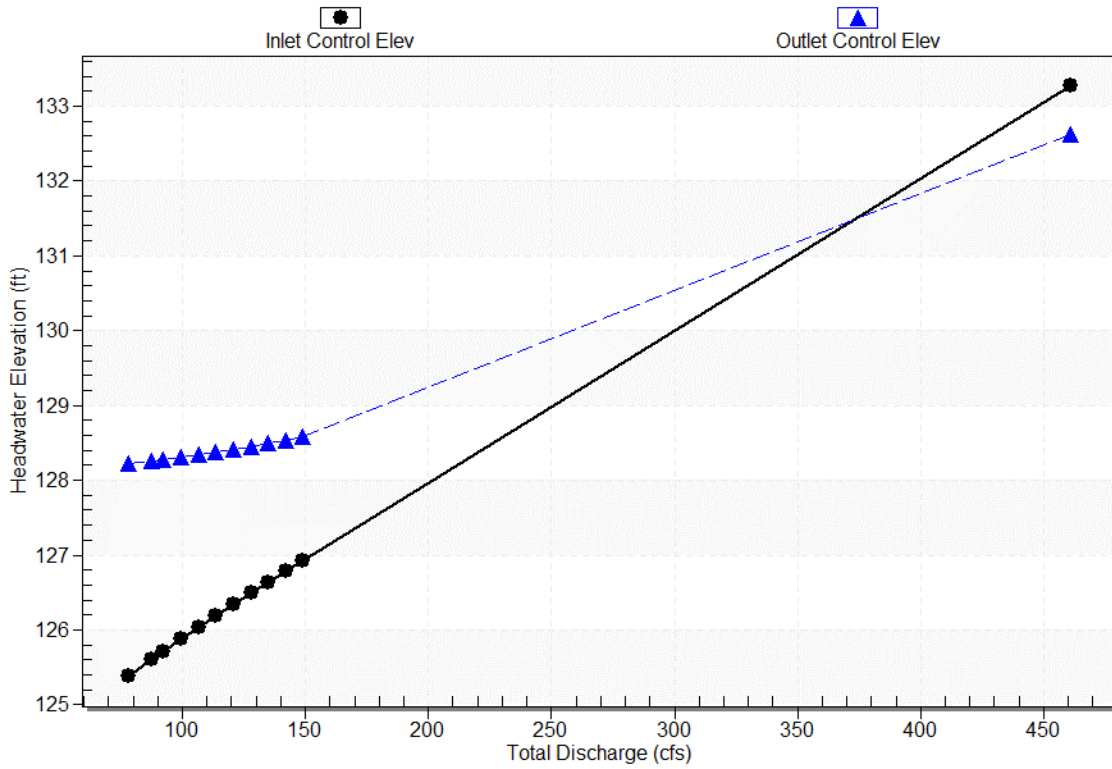

Water Surface Profile Plot for Culvert: 72inx72in Box Culvert

Crossing - CD 16 Post, Design Discharge - 87.7 cfs

Culvert - 72inx72in Box Culvert, Culvert Discharge - 87.7 cfs

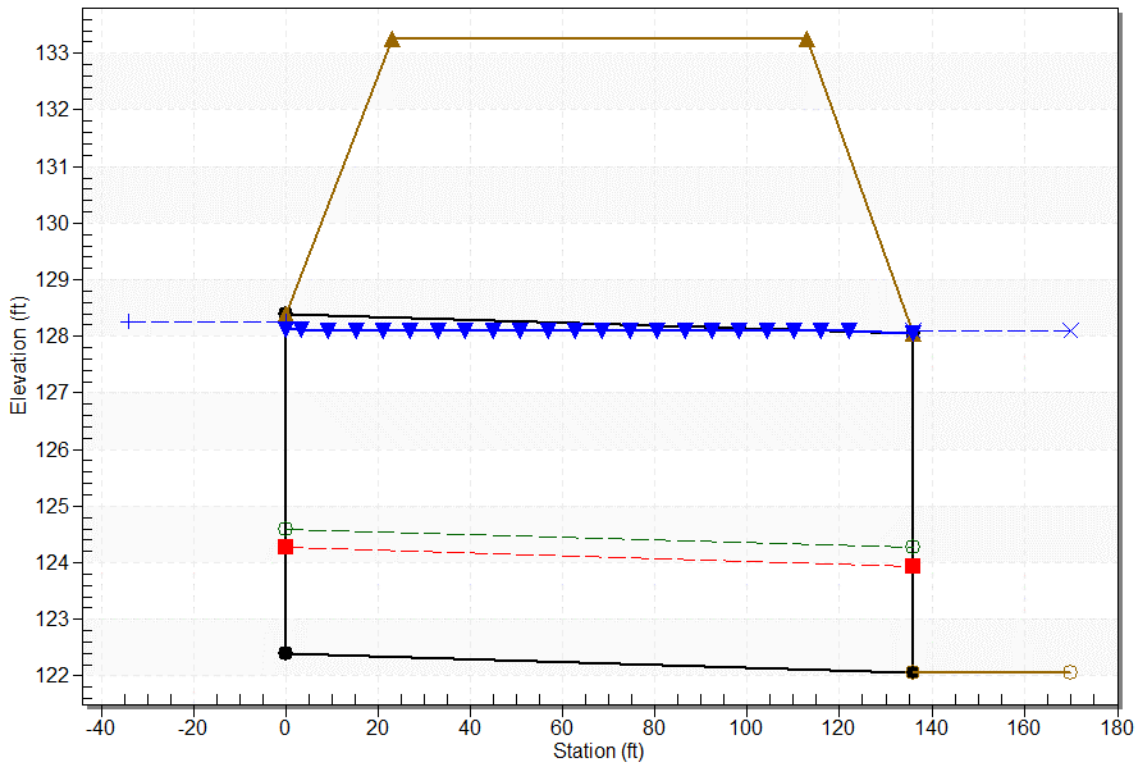

Site Data - 72inx72in Box Culvert

Site Data Option: Culvert Invert Data

Inlet Station: 0.00 ft

Inlet Elevation: 122.39 ft

Outlet Station: 136.00 ft

Outlet Elevation: 122.06 ft

Number of Barrels: 1

Culvert Data Summary - 72inx72in Box Culvert

Barrel Shape: Concrete Box

Barrel Span: 6.00 ft

Barrel Rise: 6.00 ft

Barrel Material: Concrete

Embedment: 0.00 in

Barrel Manning's n: 0.0130

Culvert Type: Straight

Inlet Configuration: Square Edge (90°) Headwall

Inlet Depression: None

Tailwater Data for Crossing: CD 16 Post

Table 4 - Downstream Channel Rating Curve (Crossing: CD 16 Post)

Flow (cfs)	Water Surface Elev (ft)	Depth (ft)
78.31	128.09	6.03
87.70	128.09	6.03
92.47	128.09	6.03
99.54	128.09	6.03
106.62	128.09	6.03
113.70	128.09	6.03
120.78	128.09	6.03
127.86	128.09	6.03
134.93	128.09	6.03
142.01	128.09	6.03
149.09	128.09	6.03

Tailwater Channel Data - CD 16 Post

Tailwater Channel Option: Enter Constant Tailwater Elevation

Constant Tailwater Elevation: 128.09 ft

Roadway Data for Crossing: CD 16 Post

Roadway Profile Shape: Constant Roadway Elevation

Crest Length: 793.00 ft

Crest Elevation: 133.25 ft

Roadway Surface: Paved

Roadway Top Width: 90.00 ft

Cross Drain
20

CD 20

CD 20 is simulated in the Haines City Watershed Model. The discharge rates are based on the output from the Haines City Watershed Model. However, the 500 year design storm discharge rate is estimated using the FDOT Drainage Design Guide Section 4.7.1 Method 1. Results are found below in Table D-1.

Estimated discharges as follows:

i. 25 yr. $Q = AV$

where A = Existing Culvert Area

V = 6 feet per second (Confirm this value with the District Drainage Engineer; some districts use a lower velocity)

ii. 100 yr. $Q = 1.4 \times (25 \text{ yr } Q)$

iii. 500 yr. $Q = 1.7 \times (100 \text{ yr } Q)$

ICPR Output	Q (50)	33.65
ICPR Output	Q (100)	40.36
Estimated	Q (500)	68.61

Table D-1

Pipe Link: RB3050A	Upstream	Downstream
Scenario: HC_WMP	Invert: 125.69 ft	Invert: 125.47 ft
From Node: NB3050	Manning's N: 0.0110	Manning's N: 0.0110
To Node: NB3260	Geometry: Circular	Geometry: Circular
Link Count: 1	Max Depth: 3.00 ft	Max Depth: 3.00 ft
Flow Direction: Both	Bottom Clip	
Damping: 0.0000 ft	Default: 0.00 ft	Default: 0.00 ft
Length: 149.00 ft	Op Table:	Op Table:
FHWA Code: 0	Ref Node:	Ref Node:
Entr Loss Coef: 0.50	Manning's N: 0.0000	Manning's N: 0.0000
Exit Loss Coef: 0.00	Top Clip	
Bend Loss Coef: 0.00	Default: 0.00 ft	Default: 0.00 ft
Bend Location: 0.00 dec	Op Table:	Op Table:
Energy Switch: Energy	Ref Node:	Ref Node:
	Manning's N: 0.0000	Manning's N: 0.0000

Comment: Imported from Peace Creek.

Sim	Link Name	Maximum Flow Rate [cfs]	Time to Maximum Flow Rate [hrs]	Minimum Flow Rate [cfs]	Time to Minimum Flow Rate [hrs]
100yr24hr	RB3050A	40.36	13.7378	0.00	0.0000
50yr24hr	RB3050A	33.65	13.5270	0.00	0.0000

HY-8 Culvert Analysis Report

Crossing Discharge Data

Discharge Selection Method: Specify Minimum, Design, and Maximum Flow

Minimum Flow: 33.65 cfs

Design Flow: 40.36 cfs

Maximum Flow: 68.61 cfs

Table 1 - Summary of Culvert Flows at Crossing: CD 20 Pre

Headwater Elevation (ft)	Total Discharge (cfs)	36in pipe Discharge (cfs)	Roadway Discharge (cfs)	Iterations
129.13	33.65	33.65	0.00	1
129.27	37.15	37.15	0.00	1
129.42	40.36	40.36	0.00	1
129.60	44.14	44.14	0.00	1
129.79	47.63	47.63	0.00	1
129.99	51.13	51.13	0.00	1
130.20	54.63	54.63	0.00	1
130.43	58.12	58.12	0.00	1
130.68	61.62	61.62	0.00	1
130.93	65.11	65.11	0.00	1
131.20	68.61	68.61	0.00	1
132.74	84.48	84.48	0.00	Overtopping

Rating Curve Plot for Crossing: CD 20 Pre

Total Rating Curve
Crossing: CD 20 Pre

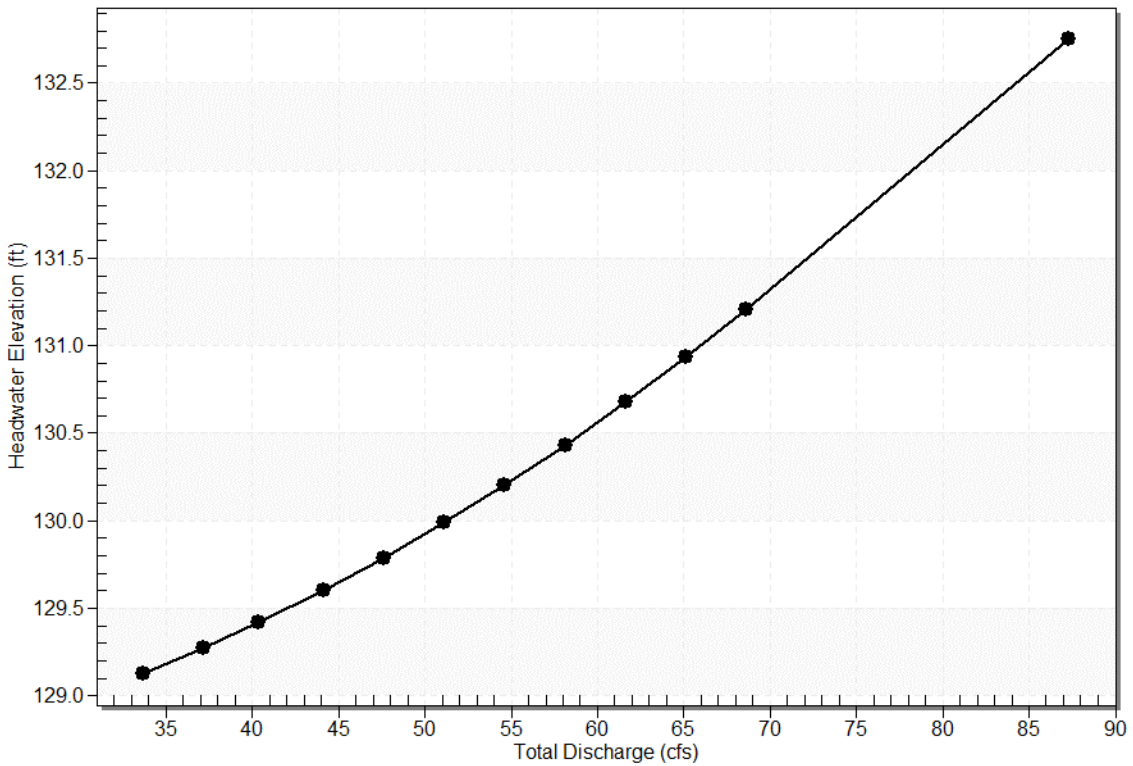

Culvert Data: 36in pipe

Table 1 - Culvert Summary Table: 36in pipe

Total Discharge (cfs)	Culvert Discharge (cfs)	Headwater Elevation (ft)	Inlet Control Depth (ft)	Outlet Control Depth (ft)	Flow Type	Normal Depth (ft)	Critical Depth (ft)	Outlet Depth (ft)	Tailwater Depth (ft)	Outlet Velocity (ft/s)	Tailwater Velocity (ft/s)
33.65 cfs	33.65 cfs	129.13	2.80	3.438	4-FFf	2.57	1.88	3.00	3.00	4.76	0.00
37.15 cfs	37.15 cfs	129.27	2.99	3.582	4-FFf	3.00	1.98	3.00	3.00	5.26	0.00
40.36 cfs	40.36 cfs	129.42	3.17	3.726	4-FFf	3.00	2.07	3.00	3.00	5.71	0.00
44.14 cfs	44.14 cfs	129.60	3.40	3.912	4-FFf	3.00	2.16	3.00	3.00	6.24	0.00
47.63 cfs	47.63 cfs	129.79	3.62	4.098	4-FFf	3.00	2.25	3.00	3.00	6.74	0.00
51.13 cfs	51.13 cfs	129.99	3.87	4.299	4-FFf	3.00	2.33	3.00	3.00	7.23	0.00

54.63 cfs	54.63 cfs	130.20	4.13	4.51 4	4- FFf	3.00	2.40	3.00	3.00	7.73	0.00
58.12 cfs	58.12 cfs	130.43	4.41	4.74 3	4- FFf	3.00	2.47	3.00	3.00	8.22	0.00
61.62 cfs	61.62 cfs	130.68	4.71	4.98 6	4- FFf	3.00	2.53	3.00	3.00	8.72	0.00
65.11 cfs	65.11 cfs	130.93	5.02	5.24 3	4- FFf	3.00	2.59	3.00	3.00	9.21	0.00
68.61 cfs	68.61 cfs	131.20	5.35	5.51 5	4- FFf	3.00	2.64	3.00	3.00	9.71	0.00

Culvert Barrel Data

Culvert Barrel Type Straight Culvert

Inlet Elevation (invert): 125.69 ft,

Outlet Elevation (invert): 125.47 ft

Culvert Length: 130.00 ft,

Culvert Slope: 0.0017

Culvert Performance Curve Plot: 36in pipe

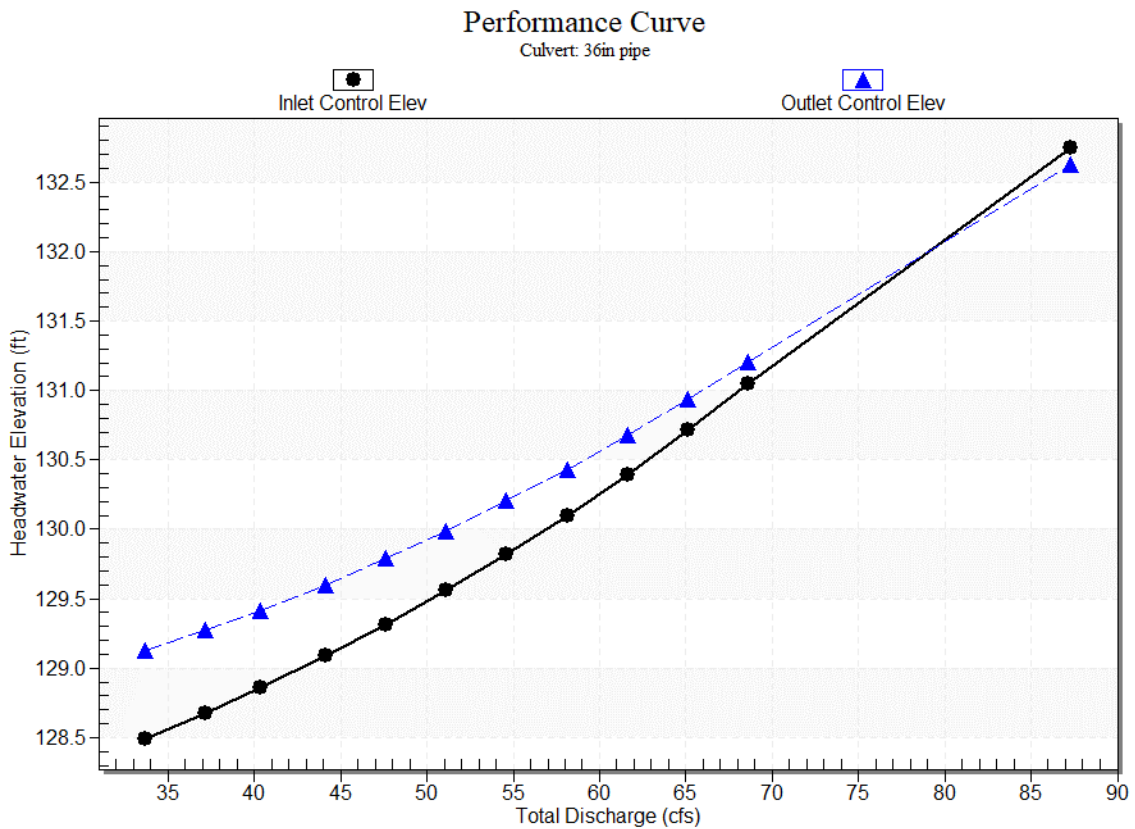

Water Surface Profile Plot for Culvert: 36in pipe

Crossing - CD 20 Pre, Design Discharge - 40.4 cfs

Culvert - 36in pipe, Culvert Discharge - 40.4 cfs

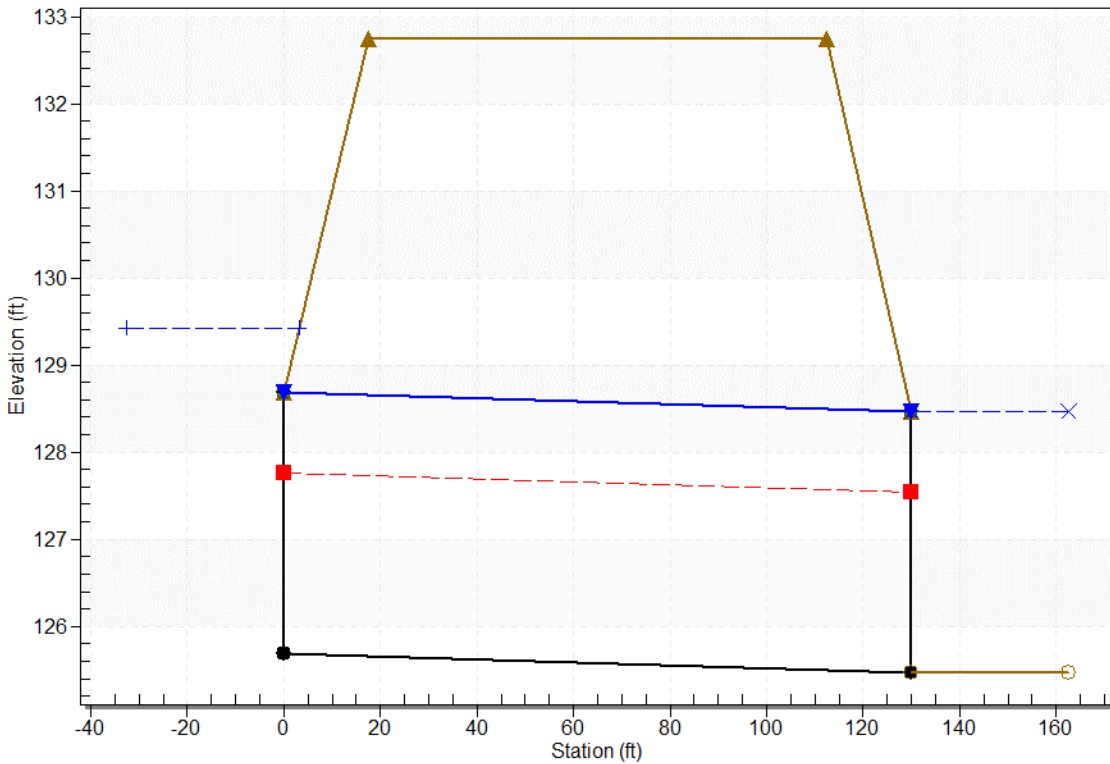

Site Data - 36in pipe

Site Data Option: Culvert Invert Data

Inlet Station: 0.00 ft

Inlet Elevation: 125.69 ft

Outlet Station: 130.00 ft

Outlet Elevation: 125.47 ft

Number of Barrels: 1

Culvert Data Summary - 36in pipe

Barrel Shape: Circular

Barrel Diameter: 3.00 ft

Barrel Material: Concrete

Embedment: 0.00 in

Barrel Manning's n: 0.0110

Culvert Type: Straight

Inlet Configuration: Beveled Edge (1:1) (Ke=0.2)

Inlet Depression: None

Tailwater Data for Crossing: CD 20 Pre

Table 2 - Downstream Channel Rating Curve (Crossing: CD 20 Pre)

Flow (cfs)	Water Surface Elev (ft)	Depth (ft)
33.65	128.47	3.00
37.15	128.47	3.00
40.36	128.47	3.00
44.14	128.47	3.00
47.63	128.47	3.00
51.13	128.47	3.00
54.63	128.47	3.00
58.12	128.47	3.00
61.62	128.47	3.00
65.11	128.47	3.00
68.61	128.47	3.00

Tailwater Channel Data - CD 20 Pre

Tailwater Channel Option: Enter Constant Tailwater Elevation

Constant Tailwater Elevation: 128.47 ft

Roadway Data for Crossing: CD 20 Pre

Roadway Profile Shape: Constant Roadway Elevation

Crest Length: 677.00 ft

Crest Elevation: 132.74 ft

Roadway Surface: Paved

Roadway Top Width: 95.00 ft

Crossing Discharge Data

Discharge Selection Method: Specify Minimum, Design, and Maximum Flow

Minimum Flow: 33.65 cfs

Design Flow: 40.36 cfs

Maximum Flow: 68.61 cfs

Table 3 - Summary of Culvert Flows at Crossing: CD 20 Post

Headwater Elevation (ft)	Total Discharge (cfs)	36in pipe Discharge (cfs)	Roadway Discharge (cfs)	Iterations
129.14	33.65	33.65	0.00	1
129.29	37.15	37.15	0.00	1
129.44	40.36	40.36	0.00	1
129.63	44.14	44.14	0.00	1
129.82	47.63	47.63	0.00	1
130.03	51.13	51.13	0.00	1
130.25	54.63	54.63	0.00	1
130.48	58.12	58.12	0.00	1
130.73	61.62	61.62	0.00	1
130.99	65.11	65.11	0.00	1
131.27	68.61	68.61	0.00	1
132.74	84.48	84.48	0.00	Overtopping

Rating Curve Plot for Crossing: CD 20 Post

Total Rating Curve
Crossing: CD 20 Post

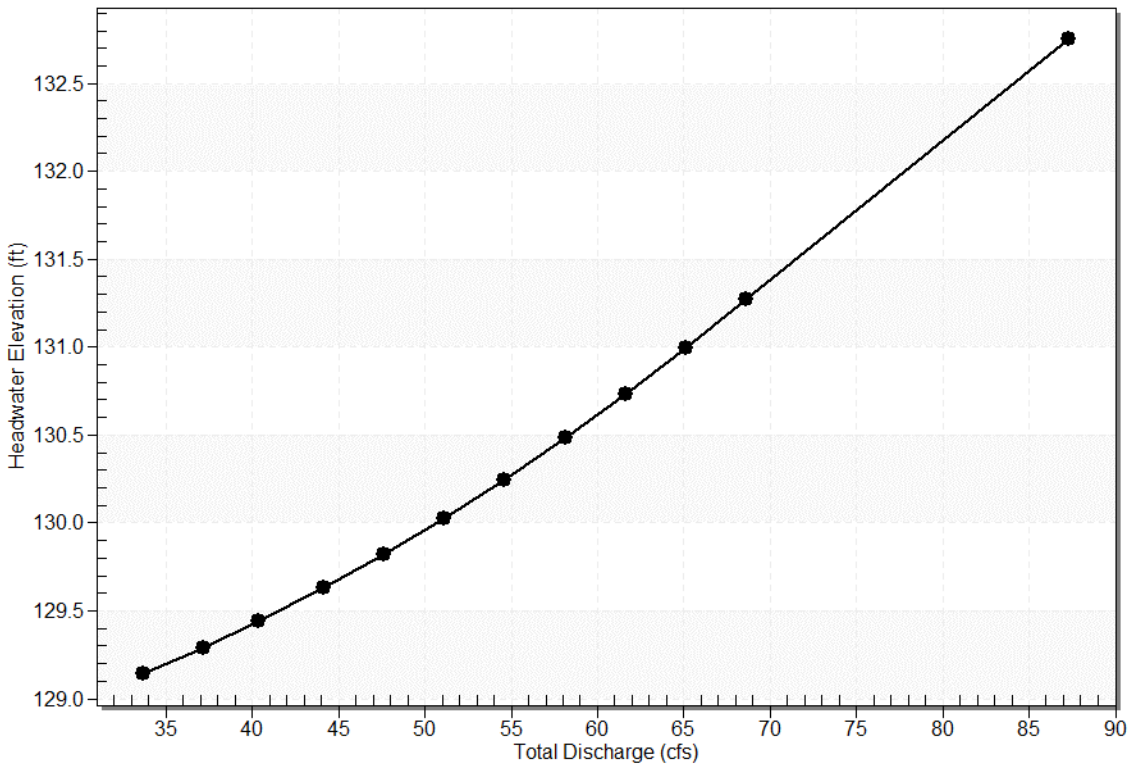

Culvert Data: 36in pipe

Table 2 - Culvert Summary Table: 36in pipe

Total Discharge (cfs)	Culvert Discharge (cfs)	Headwater Elevation (ft)	Inlet Control Depth (ft)	Outlet Control Depth (ft)	Flow Type	Normal Depth (ft)	Critical Depth (ft)	Outlet Depth (ft)	Tailwater Depth (ft)	Outlet Velocity (ft/s)	Tailwater Velocity (ft/s)
33.65 cfs	33.65 cfs	129.14	2.80	3.454	4-FFf	2.53	1.88	3.00	3.02	4.76	0.00
37.15 cfs	37.15 cfs	129.29	2.99	3.602	4-FFf	3.00	1.98	3.00	3.02	5.26	0.00
40.36 cfs	40.36 cfs	129.44	3.17	3.750	4-FFf	3.00	2.07	3.00	3.02	5.71	0.00
44.14 cfs	44.14 cfs	129.63	3.40	3.940	4-FFf	3.00	2.16	3.00	3.02	6.24	0.00
47.63 cfs	47.63 cfs	129.82	3.62	4.131	4-FFf	3.00	2.25	3.00	3.02	6.74	0.00
51.13 cfs	51.13 cfs	130.03	3.87	4.336	4-FFf	3.00	2.33	3.00	3.02	7.23	0.00

54.63 cfs	54.63 cfs	130.25	4.13	4.55 7	4- FFf	3.00	2.40	3.00	3.02	7.73	0.00
58.12 cfs	58.12 cfs	130.48	4.41	4.79 1	4- FFf	3.00	2.47	3.00	3.02	8.22	0.00
61.62 cfs	61.62 cfs	130.73	4.71	5.04 1	4- FFf	3.00	2.53	3.00	3.02	8.72	0.00
65.11 cfs	65.11 cfs	130.99	5.02	5.30 4	4- FFf	3.00	2.59	3.00	3.02	9.21	0.00
68.61 cfs	68.61 cfs	131.27	5.35	5.58 3	4- FFf	3.00	2.64	3.00	3.02	9.71	0.00

Culvert Barrel Data

Culvert Barrel Type Straight Culvert

Inlet Elevation (invert): 125.69 ft,

Outlet Elevation (invert): 125.45 ft

Culvert Length: 139.00 ft,

Culvert Slope: 0.0017

Culvert Performance Curve Plot: 36in pipe

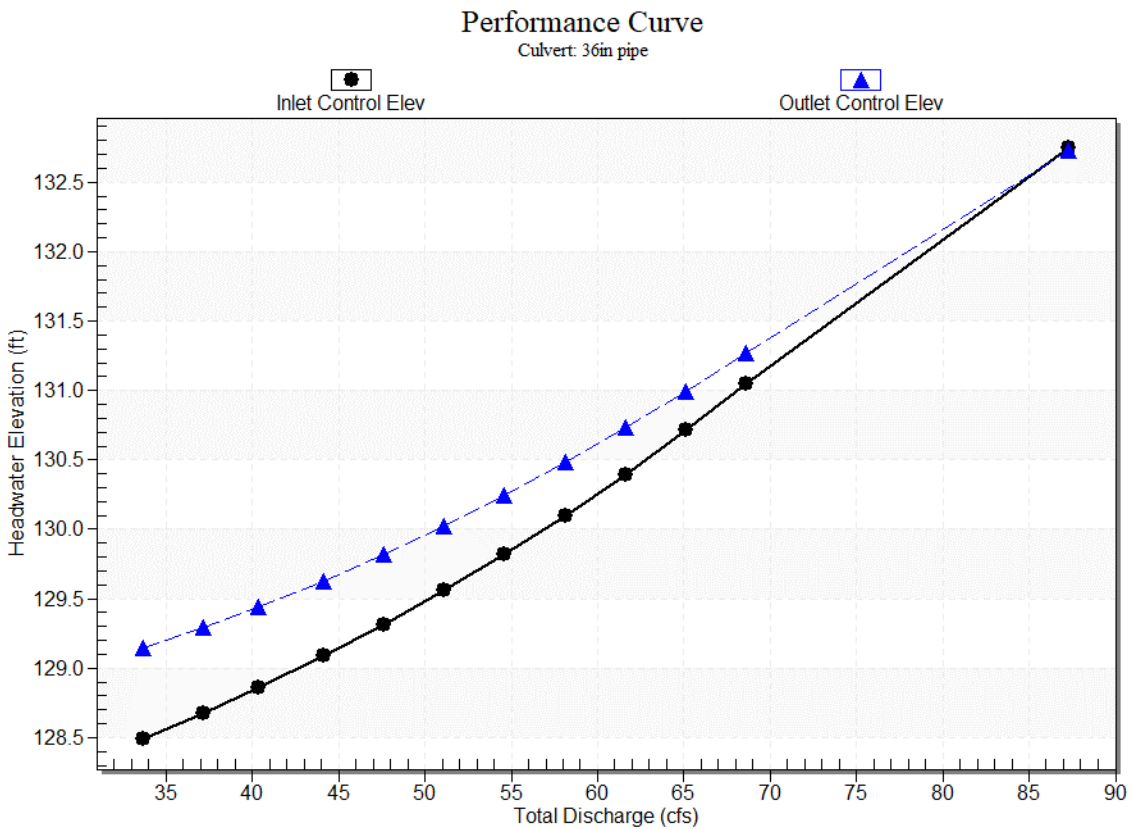

Water Surface Profile Plot for Culvert: 36in pipe

Crossing - CD 20 Post, Design Discharge - 40.4 cfs

Culvert - 36in pipe, Culvert Discharge - 40.4 cfs

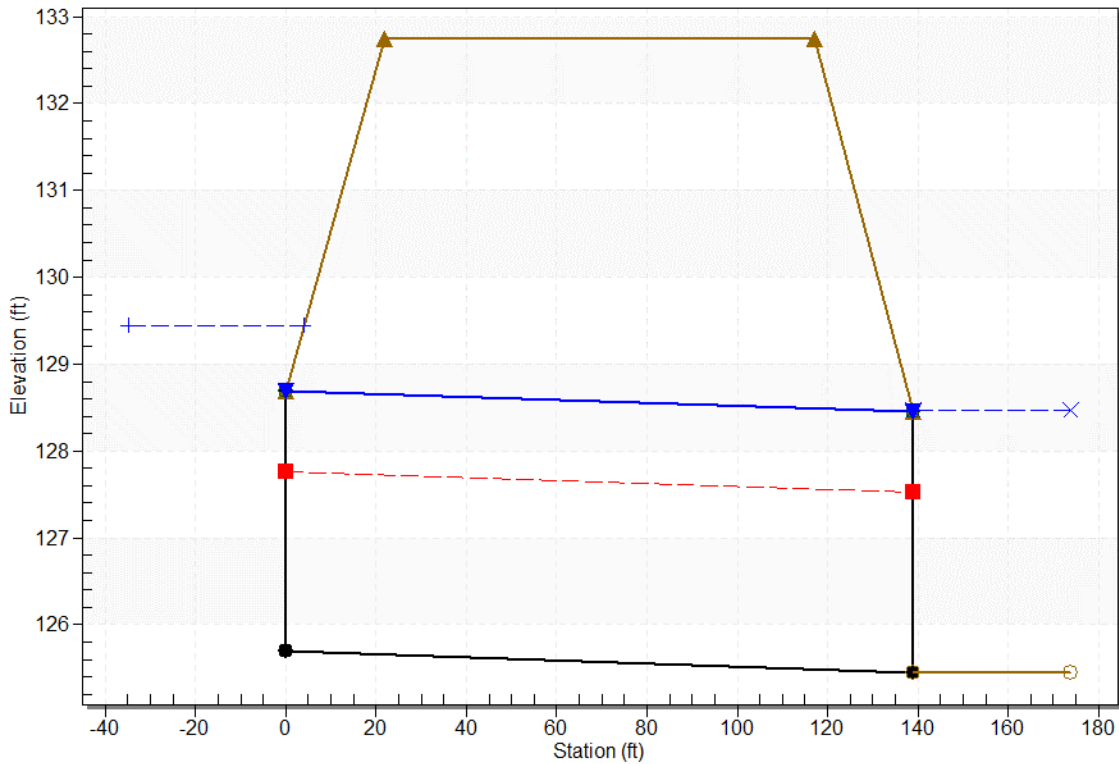

Site Data - 36in pipe

Site Data Option: Culvert Invert Data

Inlet Station: 0.00 ft

Inlet Elevation: 125.69 ft

Outlet Station: 139.00 ft

Outlet Elevation: 125.45 ft

Number of Barrels: 1

Culvert Data Summary - 36in pipe

Barrel Shape: Circular

Barrel Diameter: 3.00 ft

Barrel Material: Concrete

Embedment: 0.00 in

Barrel Manning's n: 0.0110

Culvert Type: Straight

Inlet Configuration: Beveled Edge (1:1) (Ke=0.2)

Inlet Depression: None

Tailwater Data for Crossing: CD 20 Post

Table 4 - Downstream Channel Rating Curve (Crossing: CD 20 Post)

Flow (cfs)	Water Surface Elev (ft)	Depth (ft)
33.65	128.47	3.02
37.15	128.47	3.02
40.36	128.47	3.02
44.14	128.47	3.02
47.63	128.47	3.02
51.13	128.47	3.02
54.63	128.47	3.02
58.12	128.47	3.02
61.62	128.47	3.02
65.11	128.47	3.02
68.61	128.47	3.02

Tailwater Channel Data - CD 20 Post

Tailwater Channel Option: Enter Constant Tailwater Elevation

Constant Tailwater Elevation: 128.47 ft

Roadway Data for Crossing: CD 20 Post

Roadway Profile Shape: Constant Roadway Elevation

Crest Length: 677.00 ft

Crest Elevation: 132.74 ft

Roadway Surface: Paved

Roadway Top Width: 95.00 ft

Cross Drain

22

CD 22

CD 22 data simulated in the Haines City Watershed Model; however, the output shows no flow. The discharge rates are estimated based on the existing cross drain diameter per FDOT Drainage Design Guide Section 4.7.1 Method 1.

Based on the field visit, the CD 22 has an 18" diameter.

Estimated discharges as follows:

i. 25 yr. $Q = AV$

where A = Existing Culvert Area

V = 6 feet per second (Confirm this value with the District Drainage Engineer; some districts use a lower velocity)

ii. 100 yr. $Q = 1.4 \times (25 \text{ yr } Q)$

iii. 500 yr. $Q = 1.7 \times (100 \text{ yr } Q)$

The 50 year design storm discharge rate was found using Figure E-1 below. A logarithmic trendline with an R-squared value equal to 1 was used to get the formula for the 50 year design storm discharge rate. Results are found in Table E-2.

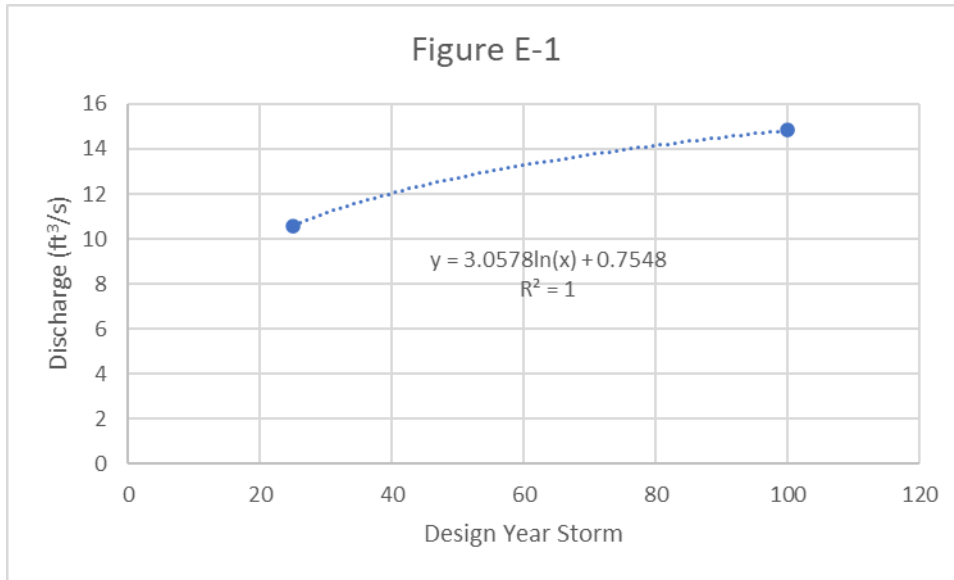

A	1.77
Q(25)	10.6
Q(50)	12.7
Q(100)	14.8
Q(500)	25.2

Table E-2

HY-8 Culvert Analysis Report

Crossing Discharge Data

Discharge Selection Method: Specify Minimum, Design, and Maximum Flow

Minimum Flow: 12.70 cfs

Design Flow: 14.80 cfs

Maximum Flow: 25.20 cfs

Table 1 - Summary of Culvert Flows at Crossing: CD 22 Pre

Headwater Elevation (ft)	Total Discharge (cfs)	18inpipe Discharge (cfs)	Roadway Discharge (cfs)	Iterations
130.82	12.70	12.70	0.00	1
131.19	13.95	13.95	0.00	1
131.38	14.80	14.55	0.14	119
131.39	16.45	14.57	1.75	5
131.39	17.70	14.57	3.04	4
131.39	18.95	14.58	4.21	3
131.39	20.20	14.59	5.48	3
131.39	21.45	14.59	6.76	3
131.40	22.70	14.60	8.03	3
131.40	23.95	14.60	9.30	3
131.40	25.20	14.61	10.56	3
131.38	14.55	14.55	0.00	Overtopping

Rating Curve Plot for Crossing: CD 22 Pre

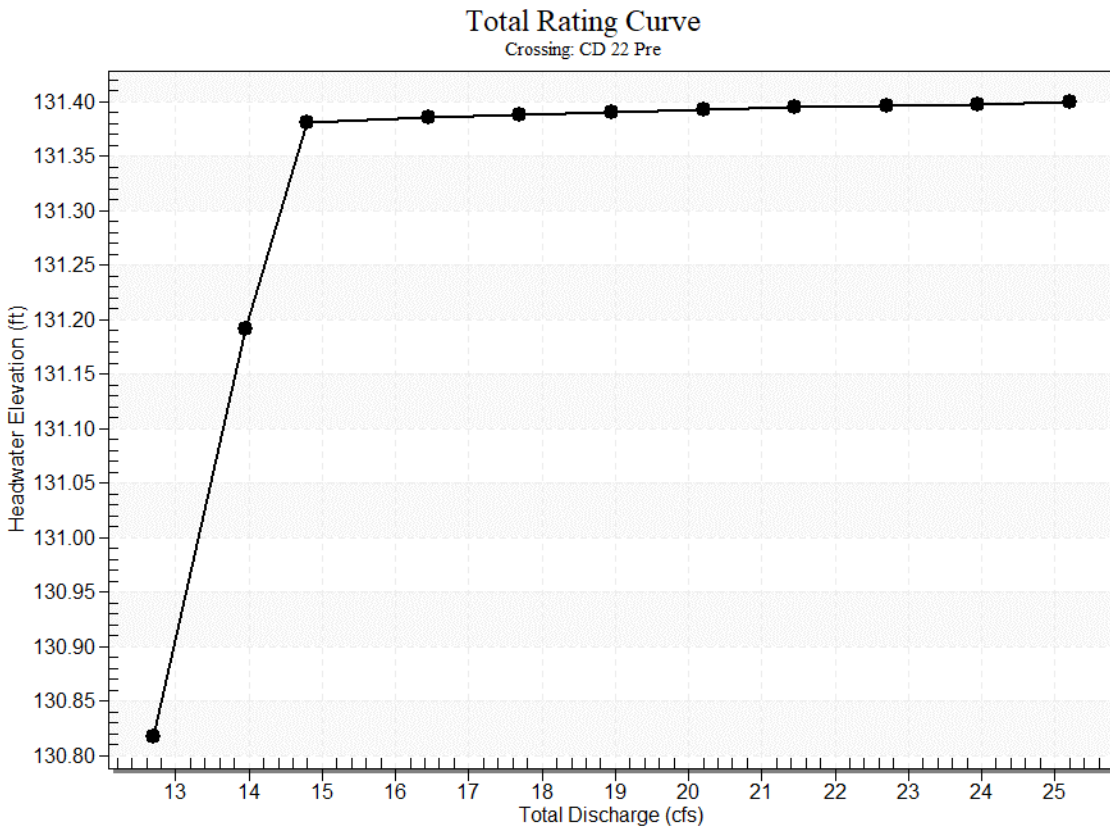

Culvert Data: 18in pipe

Table 1 - Culvert Summary Table: 18in pipe

Total Discharge (cfs)	Culvert Discharge (cfs)	Headwater Elevation (ft)	Inlet Control Depth (ft)	Outlet Control Depth (ft)	Flow Type	Normal Depth (ft)	Critical Depth (ft)	Outlet Depth (ft)	Tailwater Depth (ft)	Outlet Velocity (ft/s)	Tailwater Velocity (ft/s)
12.70 cfs	12.70 cfs	130.82	2.83	1.815	5-S2n	1.04	1.34	1.05	1.50	9.61	0.00
13.95 cfs	13.95 cfs	131.19	3.20	2.293	5-S2n	1.12	1.38	1.13	1.50	9.76	0.00
14.80 cfs	14.55 cfs	131.38	3.39	2.540	5-S2n	1.16	1.40	1.17	1.50	9.83	0.00
16.45 cfs	14.57 cfs	131.39	3.40	2.546	5-S2n	1.16	1.40	1.17	1.50	9.83	0.00

17.70 cfs	14.57 cfs	131.39	3.40	2.54 9	5- S2 n	1.16	1.40	1.17	1.50	9.83	0.00
18.95 cfs	14.58 cfs	131.39	3.40	2.55 2	5- S2 n	1.16	1.40	1.17	1.50	9.83	0.00
20.20 cfs	14.59 cfs	131.39	3.40	2.55 5	5- S2 n	1.16	1.40	1.17	1.50	9.83	0.00
21.45 cfs	14.59 cfs	131.39	3.40	2.55 7	5- S2 n	1.16	1.40	1.17	1.50	9.83	0.00
22.70 cfs	14.60 cfs	131.40	3.41	2.55 9	5- S2 n	1.16	1.40	1.18	1.50	9.83	0.00
23.95 cfs	14.60 cfs	131.40	3.41	2.56 2	5- S2 n	1.16	1.40	1.18	1.50	9.83	0.00
25.20 cfs	14.61 cfs	131.40	3.41	2.56 4	5- S2 n	1.16	1.40	1.18	1.50	9.83	0.00

Culvert Barrel Data

Culvert Barrel Type Straight Culvert

Inlet Elevation (invert): 127.99 ft,

Outlet Elevation (invert): 125.99 ft

Culvert Length: 130.02 ft,

Culvert Slope: 0.0154

Culvert Performance Curve Plot: 18inpipe

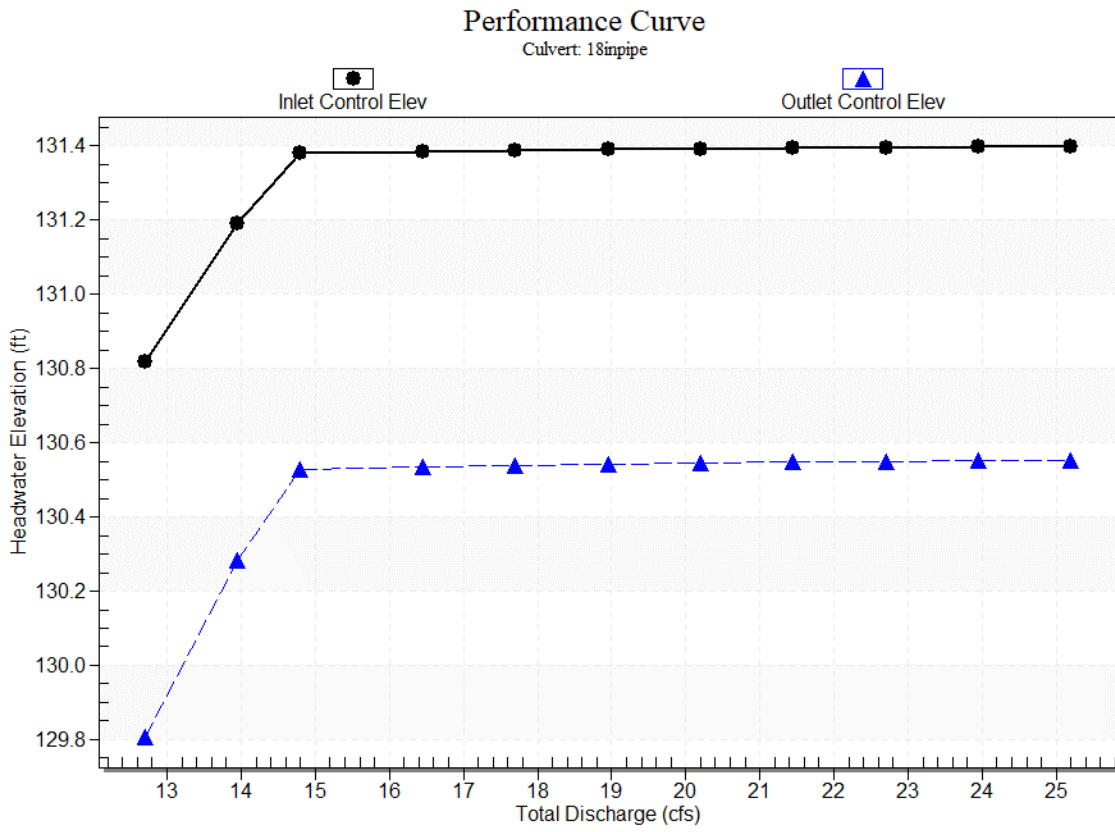

Water Surface Profile Plot for Culvert: 18inpipe

Crossing - CD 22 Pre, Design Discharge - 14.8 cfs

Culvert - 18inpipe, Culvert Discharge - 14.6 cfs

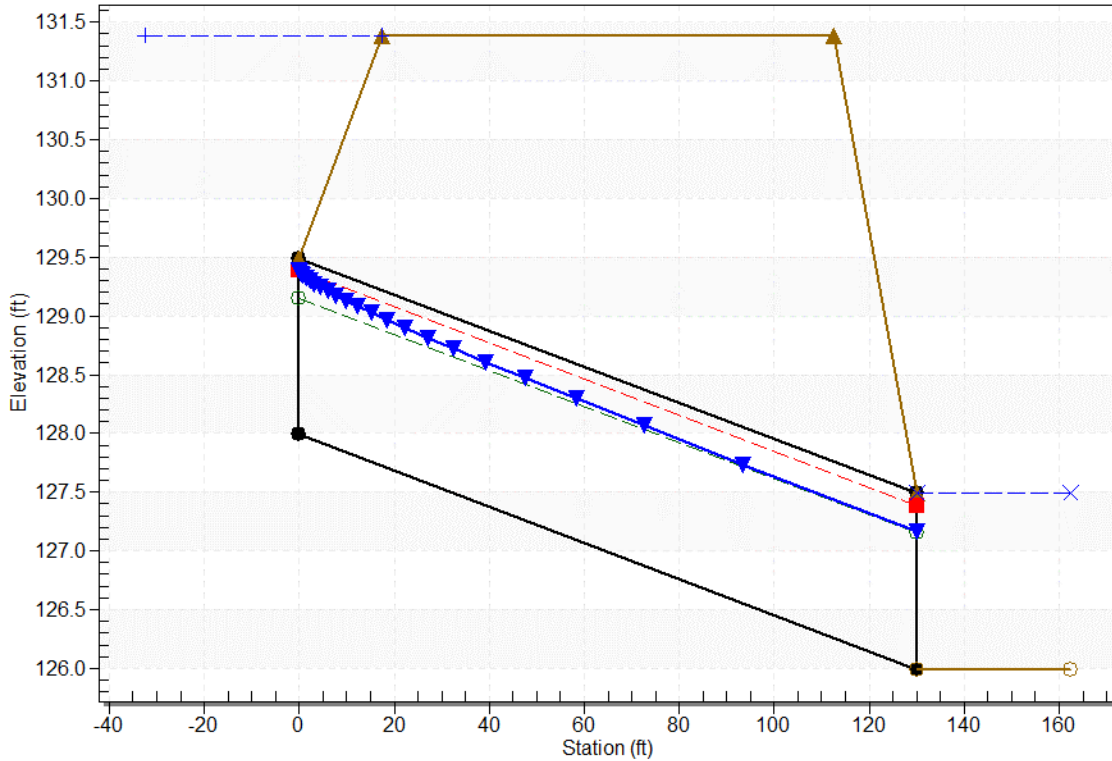

Site Data - 18inpipe

Site Data Option: Culvert Invert Data

Inlet Station: 0.00 ft

Inlet Elevation: 127.99 ft

Outlet Station: 130.00 ft

Outlet Elevation: 125.99 ft

Number of Barrels: 1

Culvert Data Summary - 18inpipe

Barrel Shape: Circular

Barrel Diameter: 1.50 ft

Barrel Material: Concrete

Embedment: 0.00 in

Barrel Manning's n: 0.0110

Culvert Type: Straight

Inlet Configuration: Beveled Edge (1:1) (Ke=0.2)

Inlet Depression: None

Tailwater Data for Crossing: CD 22 Pre

Table 2 - Downstream Channel Rating Curve (Crossing: CD 22 Pre)

Flow (cfs)	Water Surface Elev (ft)	Depth (ft)
12.70	127.49	1.50
13.95	127.49	1.50
14.80	127.49	1.50
16.45	127.49	1.50
17.70	127.49	1.50
18.95	127.49	1.50
20.20	127.49	1.50
21.45	127.49	1.50
22.70	127.49	1.50
23.95	127.49	1.50
25.20	127.49	1.50

Tailwater Channel Data - CD 22 Pre

Tailwater Channel Option: Enter Constant Tailwater Elevation

Constant Tailwater Elevation: 127.49 ft

Roadway Data for Crossing: CD 22 Pre

Roadway Profile Shape: Constant Roadway Elevation

Crest Length: 1354.00 ft

Crest Elevation: 131.38 ft

Roadway Surface: Paved

Roadway Top Width: 95.00 ft

Crossing Discharge Data

Discharge Selection Method: Specify Minimum, Design, and Maximum Flow

Minimum Flow: 12.70 cfs

Design Flow: 14.80 cfs

Maximum Flow: 25.20 cfs

Table 3 - Summary of Culvert Flows at Crossing: CD 22 Post

Headwater Elevation (ft)	Total Discharge (cfs)	18in pipe Discharge (cfs)	Roadway Discharge (cfs)	Iterations
130.82	12.70	12.70	0.00	1
131.19	13.95	13.95	0.00	1
131.38	14.80	14.55	0.14	119
131.39	16.45	14.57	1.75	5
131.39	17.70	14.57	3.04	4
131.39	18.95	14.58	4.21	3
131.39	20.20	14.59	5.48	3
131.39	21.45	14.59	6.76	3
131.40	22.70	14.60	8.03	3
131.40	23.95	14.60	9.30	3
131.40	25.20	14.61	10.56	3
131.38	14.55	14.55	0.00	Overtopping

Rating Curve Plot for Crossing: CD 22 Post

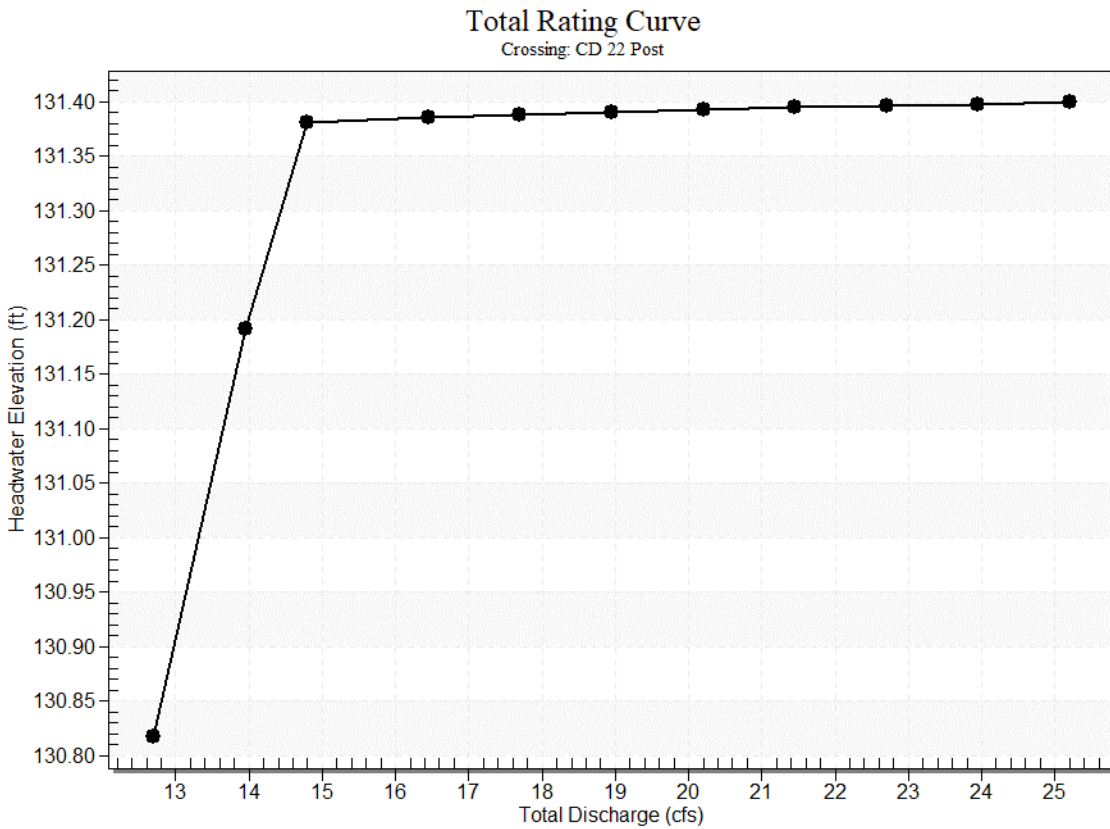

Culvert Data: 18in pipe

Table 2 - Culvert Summary Table: 18in pipe

Total Discharge (cfs)	Culvert Discharge (cfs)	Headwater Elevation (ft)	Inlet Control Depth (ft)	Outlet Control Depth (ft)	Flow Type	Normal Depth (ft)	Critical Depth (ft)	Outlet Depth (ft)	Tailwater Depth (ft)	Outlet Velocity (ft/s)	Tailwater Velocity (ft/s)
12.70 cfs	12.70 cfs	130.82	2.83	2.159	5-JS1f	1.11	1.34	1.50	1.61	7.19	0.00
13.95 cfs	13.95 cfs	131.19	3.20	2.708	5-JS1f	1.21	1.38	1.50	1.61	7.89	0.00
14.80 cfs	14.55 cfs	131.38	3.39	2.991	5-JS1f	1.27	1.40	1.50	1.61	8.23	0.00
16.45 cfs	14.57 cfs	131.39	3.40	2.998	4-FFf	1.27	1.40	1.50	1.61	8.24	0.00
17.70 cfs	14.57 cfs	131.39	3.40	3.00	4-	1.27	1.40	1.50	1.61	8.25	0.00

cfs	cfs			2	FFf						
18.95	14.58	131.39	3.40	3.00	4-	1.28	1.40	1.50	1.61	8.25	0.00
cfs	cfs			5	FFf						
20.20	14.59	131.39	3.40	3.00	5-	1.28	1.40	1.28	1.61	9.08	0.00
cfs	cfs			8	S2						
21.45	14.59	131.39	3.40	3.01	5-	1.28	1.40	1.28	1.61	9.08	0.00
cfs	cfs			1	S2						
22.70	14.60	131.40	3.41	3.01	4-	1.28	1.40	1.50	1.61	8.26	0.00
cfs	cfs			4	FFf						
23.95	14.60	131.40	3.41	3.01	4-	1.28	1.40	1.50	1.61	8.26	0.00
cfs	cfs			6	FFf						
25.20	14.61	131.40	3.41	3.01	4-	1.28	1.40	1.50	1.61	8.27	0.00
cfs	cfs			9	FFf						

Culvert Barrel Data

Culvert Barrel Type Straight Culvert

Inlet Elevation (invert): 127.99 ft,

Outlet Elevation (invert): 125.88 ft

Culvert Length: 137.02 ft,

Culvert Slope: 0.0154

Culvert Performance Curve Plot: 18in pipe

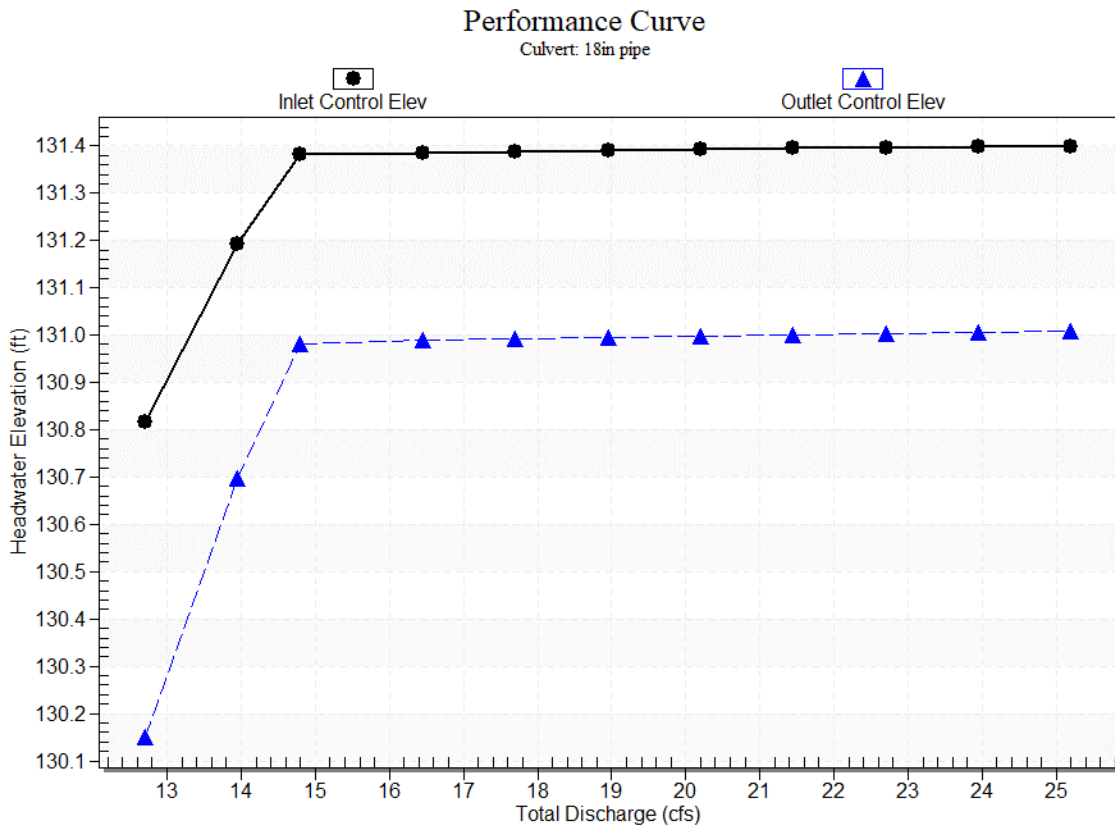

Water Surface Profile Plot for Culvert: 18in pipe

Crossing - CD 22 Post, Design Discharge - 14.8 cfs

Culvert - 18in pipe, Culvert Discharge - 14.6 cfs

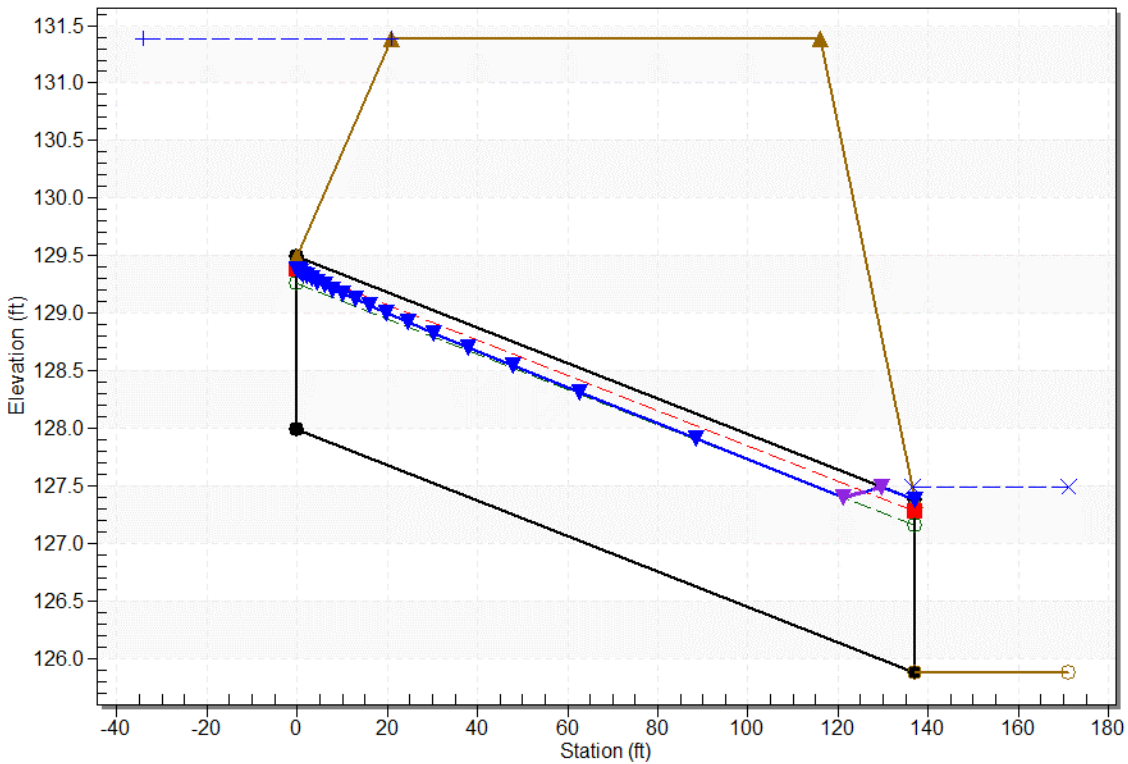

Site Data - 18in pipe

Site Data Option: Culvert Invert Data

Inlet Station: 0.00 ft

Inlet Elevation: 127.99 ft

Outlet Station: 137.00 ft

Outlet Elevation: 125.88 ft

Number of Barrels: 1

Culvert Data Summary - 18in pipe

Barrel Shape: Circular

Barrel Diameter: 1.50 ft

Barrel Material: Concrete

Embedment: 0.00 in

Barrel Manning's n: 0.0120

Culvert Type: Straight

Inlet Configuration: Beveled Edge (1:1) ($K_e=0.2$)

Inlet Depression: None

Tailwater Data for Crossing: CD 22 Post

Table 4 - Downstream Channel Rating Curve (Crossing: CD 22 Post)

Flow (cfs)	Water Surface Elev (ft)	Depth (ft)
12.70	127.49	1.61
13.95	127.49	1.61
14.80	127.49	1.61
16.45	127.49	1.61
17.70	127.49	1.61
18.95	127.49	1.61
20.20	127.49	1.61
21.45	127.49	1.61
22.70	127.49	1.61
23.95	127.49	1.61
25.20	127.49	1.61

Tailwater Channel Data - CD 22 Post

Tailwater Channel Option: Enter Constant Tailwater Elevation

Constant Tailwater Elevation: 127.49 ft

Roadway Data for Crossing: CD 22 Post

Roadway Profile Shape: Constant Roadway Elevation

Crest Length: 1354.00 ft

Crest Elevation: 131.38 ft

Roadway Surface: Paved

Roadway Top Width: 95.00 ft

Cross Drain
25

CD 25

CD 25 is simulated in the Haines City Watershed Model. The discharge rates are based on the output from the Haines City Watershed Model. However, the 500 year design storm discharge rate is estimated using the FDOT Drainage Design Guide Section 4.7.1 Method 1. Results are found below in Table F-1.

Estimated discharges as follows:

i. 25 yr. $Q = AV$

where A = Existing Culvert Area

V = 6 feet per second (Confirm this value with the District Drainage Engineer; some districts use a lower velocity)

ii. 100 yr. $Q = 1.4 \times (25 \text{ yr } Q)$

iii. 500 yr. $Q = 1.7 \times (100 \text{ yr } Q)$

ICPR Output	Q (50)	17.81
ICPR Output	Q (100)	19.65
Estimated	Q (500)	33.41

Table F-1

Pipe Link: RA0300A	Upstream	Downstream
Scenario: HC_WMP	Invert: 123.55 ft	Invert: 123.26 ft
From Node: NA0300	Manning's N: 0.0110	Manning's N: 0.0110
To Node: NA0305	Geometry: Circular	Geometry: Circular
Link Count: 1	Max Depth: 2.50 ft	Max Depth: 2.50 ft
Flow Direction: Both	Bottom Clip	
Damping: 0.0000 ft	Default: 0.00 ft	Default: 0.00 ft
Length: 137.00 ft	Op Table:	Op Table:
FHWA Code: 0	Ref Node:	Ref Node:
Entr Loss Coef: 0.50	Manning's N: 0.0000	Manning's N: 0.0000
Exit Loss Coef: 0.00	Top Clip	
Bend Loss Coef: 0.00	Default: 0.00 ft	Default: 0.00 ft
Bend Location: 0.00 dec	Op Table:	Op Table:
Energy Switch: Energy	Ref Node:	Ref Node:
	Manning's N: 0.0000	Manning's N: 0.0000
Comment: Imported from Peace Creek.		

Sim	Link Name	Maximum Flow Rate [cfs]	Time to Maximum Flow Rate [hrs]	Minimum Flow Rate [cfs]	Time to Minimum Flow Rate [hrs]
100yr24hr	RA0300A	19.65	12.3463	0.00	0.0000
50yr24hr	RA0300A	17.81	12.3173	0.00	0.0000

HY-8 Culvert Analysis Report

Crossing Discharge Data

Discharge Selection Method: Specify Minimum, Design, and Maximum Flow

Minimum Flow: 17.81 cfs

Design Flow: 19.65 cfs

Maximum Flow: 33.41 cfs

Table 1 - Summary of Culvert Flows at Crossing: CD 25 Pre

Headwater Elevation (ft)	Total Discharge (cfs)	30in pipe Discharge (cfs)	Roadway Discharge (cfs)	Iterations
126.19	17.81	17.81	0.00	1
126.28	19.65	19.65	0.00	1
126.35	20.93	20.93	0.00	1
126.44	22.49	22.49	0.00	1
126.54	24.05	24.05	0.00	1
126.65	25.61	25.61	0.00	1
126.76	27.17	27.17	0.00	1
126.88	28.73	28.73	0.00	1
127.00	30.29	30.29	0.00	1
127.13	31.85	31.85	0.00	1
127.27	33.41	33.41	0.00	1
131.29	63.93	63.93	0.00	Overtopping

Rating Curve Plot for Crossing: CD 25 Pre

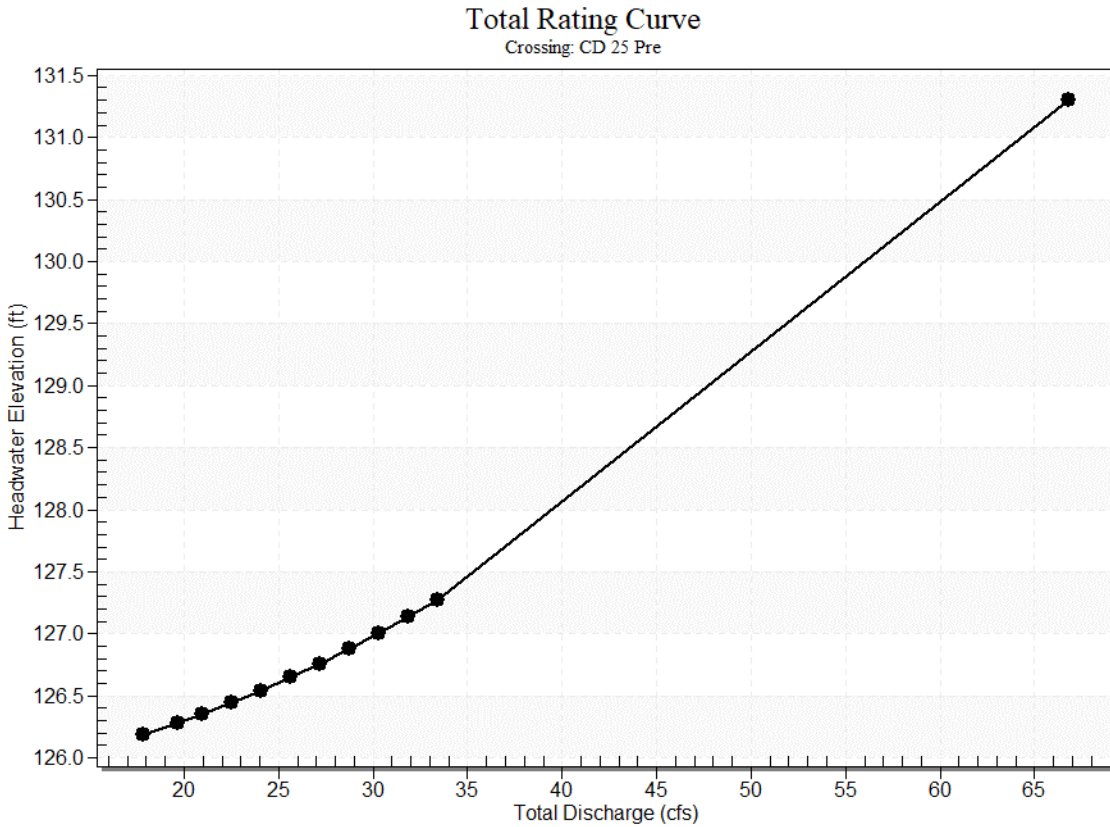

Culvert Data: 30in pipe

Table 1 - Culvert Summary Table: 30in pipe

Total Discharge (cfs)	Culvert Discharge (cfs)	Headwater Elevation (ft)	Inlet Control Depth (ft)	Outlet Control Depth (ft)	Flow Type	Normal Depth (ft)	Critical Depth (ft)	Outlet Depth (ft)	Tailwater Depth (ft)	Outlet Velocity (ft/s)	Tailwater Velocity (ft/s)
17.81 cfs	17.81 cfs	126.19	2.09	2.639	4-FFf	1.69	1.43	2.50	2.50	3.63	0.00
19.65 cfs	19.65 cfs	126.28	2.21	2.732	4-FFf	1.82	1.50	2.50	2.50	4.00	0.00
20.93 cfs	20.93 cfs	126.35	2.30	2.803	4-FFf	1.92	1.55	2.50	2.50	4.26	0.00
22.49 cfs	22.49 cfs	126.44	2.41	2.894	4-FFf	2.06	1.61	2.50	2.50	4.58	0.00
24.05 cfs	24.05 cfs	126.54	2.52	2.993	4-FFf	2.50	1.67	2.50	2.50	4.90	0.00
25.61 cfs	25.61 cfs	126.65	2.64	3.097	4-FFf	2.50	1.72	2.50	2.50	5.22	0.00

27.17 cfs	27.17 cfs	126.76	2.76	3.20 9	4- FFf	2.50	1.78	2.50	2.50	5.54	0.00
28.73 cfs	28.73 cfs	126.88	2.89	3.32 7	4- FFf	2.50	1.83	2.50	2.50	5.85	0.00
30.29 cfs	30.29 cfs	127.00	3.03	3.45 1	4- FFf	2.50	1.88	2.50	2.50	6.17	0.00
31.85 cfs	31.85 cfs	127.13	3.17	3.58 3	4- FFf	2.50	1.92	2.50	2.50	6.49	0.00
33.41 cfs	33.41 cfs	127.27	3.32	3.72 0	4- FFf	2.50	1.97	2.50	2.50	6.81	0.00

Culvert Barrel Data

Culvert Barrel Type Straight Culvert

Inlet Elevation (invert): 123.55 ft,

Outlet Elevation (invert): 123.26 ft

Culvert Length: 137.00 ft,

Culvert Slope: 0.0021

Culvert Performance Curve Plot: 30in pipe

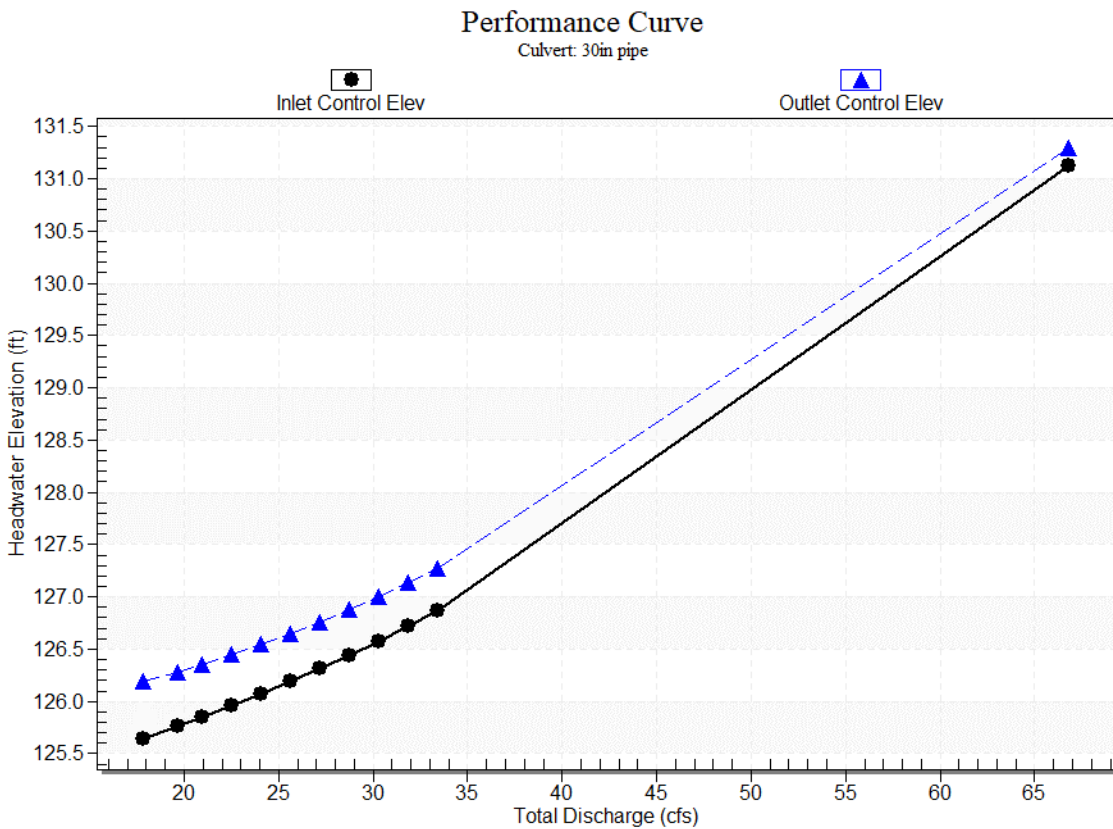

Water Surface Profile Plot for Culvert: 30in pipe

Crossing - CD 25 Pre, Design Discharge - 19.6 cfs

Culvert - 30in pipe, Culvert Discharge - 19.6 cfs

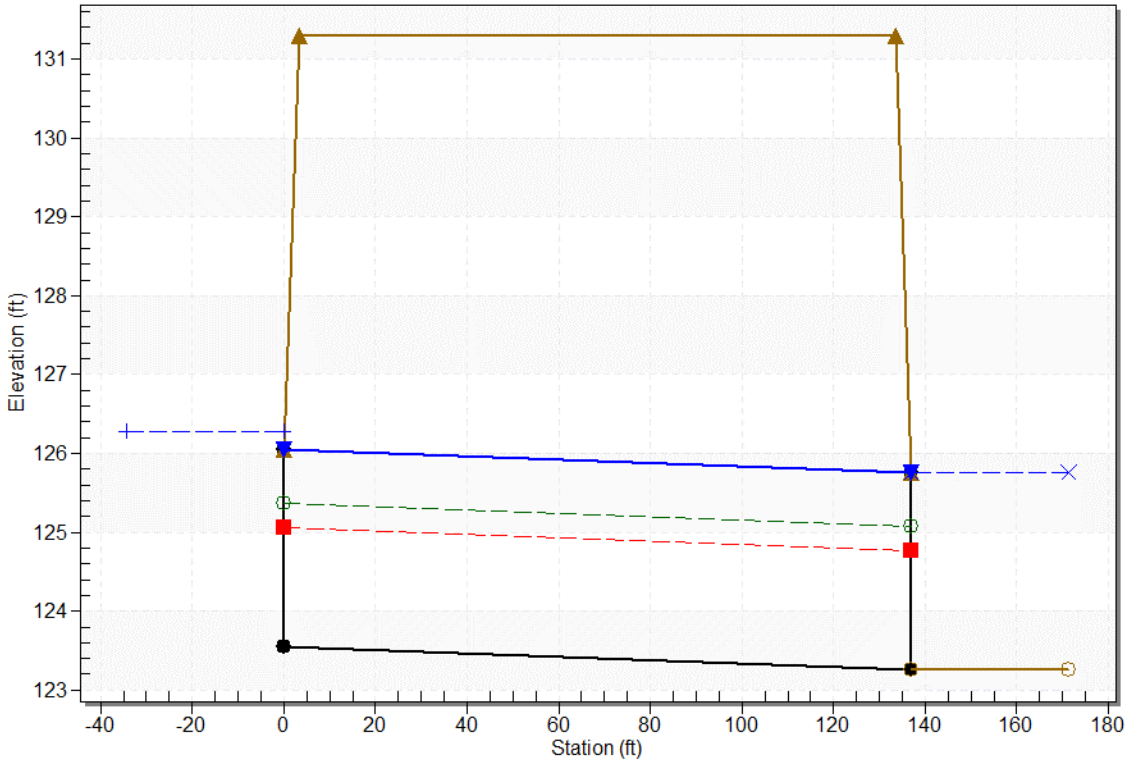

Site Data - 30in pipe

Site Data Option: Culvert Invert Data

Inlet Station: 0.00 ft

Inlet Elevation: 123.55 ft

Outlet Station: 137.00 ft

Outlet Elevation: 123.26 ft

Number of Barrels: 1

Culvert Data Summary - 30in pipe

Barrel Shape: Circular

Barrel Diameter: 2.50 ft

Barrel Material: Concrete

Embedment: 0.00 in

Barrel Manning's n: 0.0110

Culvert Type: Straight

Inlet Configuration: Beveled Edge (1:1) (Ke=0.2)

Inlet Depression: None

Tailwater Data for Crossing: CD 25 Pre

Table 2 - Downstream Channel Rating Curve (Crossing: CD 25 Pre)

Flow (cfs)	Water Surface Elev (ft)	Depth (ft)
17.81	125.76	2.50
19.65	125.76	2.50
20.93	125.76	2.50
22.49	125.76	2.50
24.05	125.76	2.50
25.61	125.76	2.50
27.17	125.76	2.50
28.73	125.76	2.50
30.29	125.76	2.50
31.85	125.76	2.50
33.41	125.76	2.50

Tailwater Channel Data - CD 25 Pre

Tailwater Channel Option: Enter Constant Tailwater Elevation

Constant Tailwater Elevation: 125.76 ft

Roadway Data for Crossing: CD 25 Pre

Roadway Profile Shape: Constant Roadway Elevation

Crest Length: 1000.00 ft

Crest Elevation: 131.29 ft

Roadway Surface: Paved

Roadway Top Width: 130.00 ft

Crossing Discharge Data

Discharge Selection Method: Specify Minimum, Design, and Maximum Flow

Minimum Flow: 17.81 cfs

Design Flow: 19.65 cfs

Maximum Flow: 33.41 cfs

Table 3 - Summary of Culvert Flows at Crossing: CD 25 Post

Headwater Elevation (ft)	Total Discharge (cfs)	30in pipe Discharge (cfs)	Roadway Discharge (cfs)	Iterations
126.19	17.81	17.81	0.00	1
126.29	19.65	19.65	0.00	1
126.37	20.93	20.93	0.00	1
126.47	22.49	22.49	0.00	1
126.57	24.05	24.05	0.00	1
126.68	25.61	25.61	0.00	1
126.79	27.17	27.17	0.00	1
126.92	28.73	28.73	0.00	1
127.04	30.29	30.29	0.00	1
127.18	31.85	31.85	0.00	1
127.32	33.41	33.41	0.00	1
131.29	62.86	62.86	0.00	Overtopping

Rating Curve Plot for Crossing: CD 25 Post

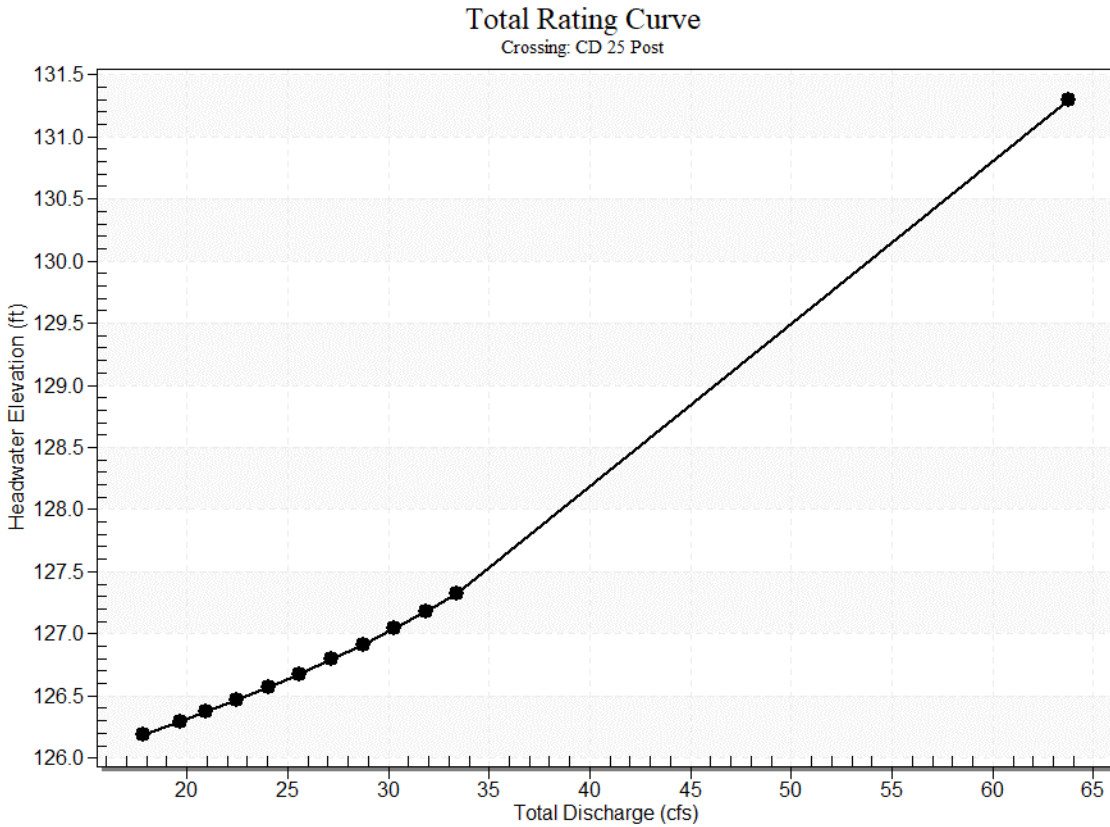

Culvert Data: 30in pipe

Table 2 - Culvert Summary Table: 30in pipe

Total Discharge (cfs)	Culvert Discharge (cfs)	Headwater Elevation (ft)	Inlet Control Depth (ft)	Outlet Control Depth (ft)	Flow Type	Normal Depth (ft)	Critical Depth (ft)	Outlet Depth (ft)	Tailwater Depth (ft)	Outlet Velocity (ft/s)	Tailwater Velocity (ft/s)
17.81 cfs	17.81 cfs	126.19	2.09	2.641	3-M1f	1.69	1.43	2.50	2.52	3.63	0.00
19.65 cfs	19.65 cfs	126.29	2.21	2.739	3-M1f	1.83	1.50	2.50	2.52	4.00	0.00
20.93 cfs	20.93 cfs	126.37	2.30	2.820	3-M1f	1.93	1.55	2.50	2.52	4.26	0.00
22.49 cfs	22.49 cfs	126.47	2.41	2.918	4-FFf	2.08	1.61	2.50	2.52	4.58	0.00
24.05 cfs	24.05 cfs	126.57	2.52	3.02	4-	2.50	1.67	2.50	2.52	4.90	0.00

cfs	cfs			0	FFf						
25.61	25.61	126.68	2.64	3.12	4-	2.50	1.72	2.50	2.52	5.22	0.00
cfs	cfs			8	FFf						
27.17	27.17	126.79	2.76	3.24	4-	2.50	1.78	2.50	2.52	5.54	0.00
cfs	cfs			3	FFf						
28.73	28.73	126.92	2.89	3.36	4-	2.50	1.83	2.50	2.52	5.85	0.00
cfs	cfs			5	FFf						
30.29	30.29	127.04	3.03	3.49	4-	2.50	1.88	2.50	2.52	6.17	0.00
cfs	cfs			4	FFf						
31.85	31.85	127.18	3.17	3.63	4-	2.50	1.92	2.50	2.52	6.49	0.00
cfs	cfs			0	FFf						
33.41	33.41	127.32	3.32	3.77	4-	2.50	1.97	2.50	2.52	6.81	0.00
cfs	cfs			2	FFf						

Culvert Barrel Data

Culvert Barrel Type Straight Culvert

Inlet Elevation (invert): 123.55 ft,

Outlet Elevation (invert): 123.24 ft

Culvert Length: 148.00 ft,

Culvert Slope: 0.0021

Culvert Performance Curve Plot: 30in pipe

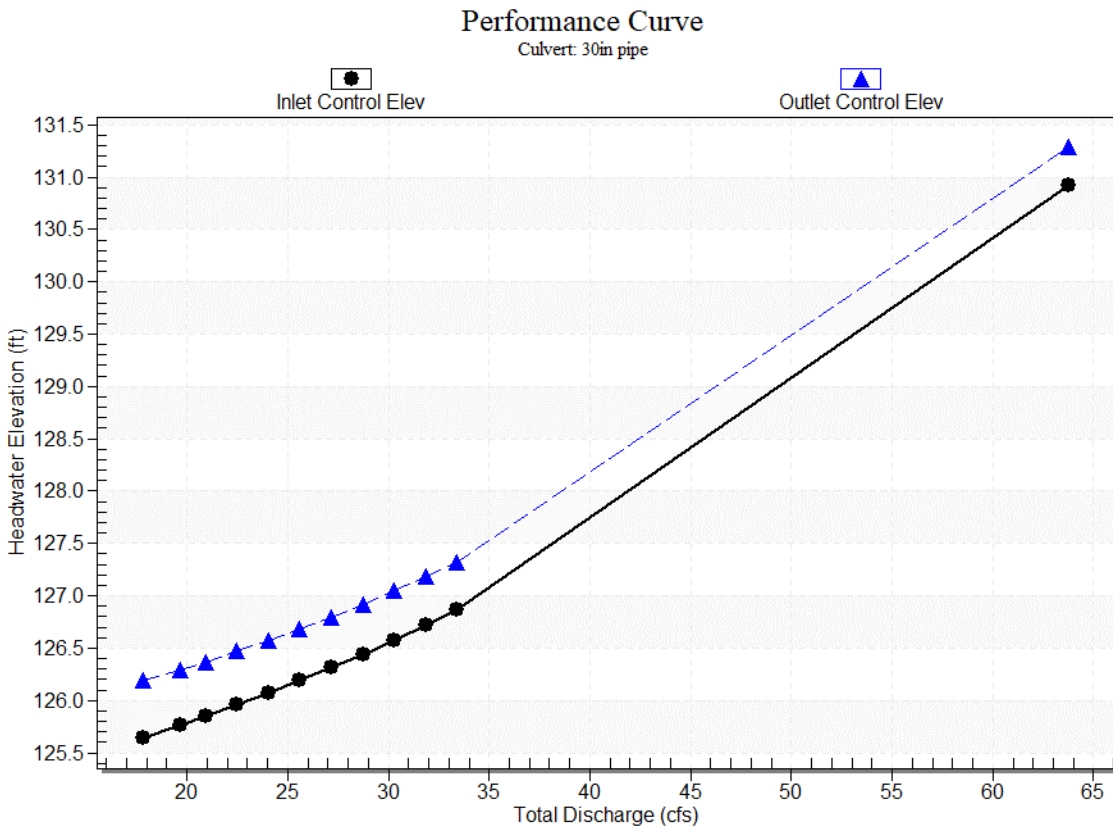

Water Surface Profile Plot for Culvert: 30in pipe

Crossing - CD 25 Post, Design Discharge - 19.6 cfs
Culvert - 30in pipe, Culvert Discharge - 19.6 cfs

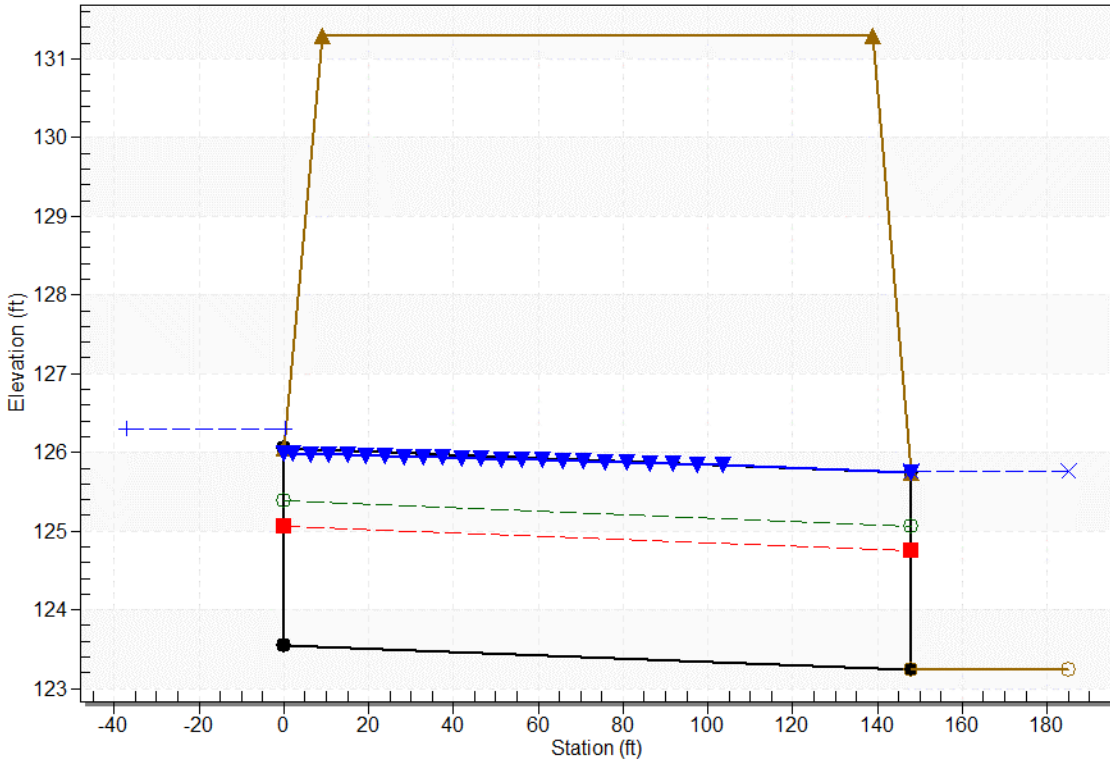

Site Data - 30in pipe

Site Data Option: Culvert Invert Data

Inlet Station: 0.00 ft

Inlet Elevation: 123.55 ft

Outlet Station: 148.00 ft

Outlet Elevation: 123.24 ft

Number of Barrels: 1

Culvert Data Summary - 30in pipe

Barrel Shape: Circular

Barrel Diameter: 2.50 ft

Barrel Material: Concrete

Embedment: 0.00 in

Barrel Manning's n: 0.0110

Culvert Type: Straight

Inlet Configuration: Beveled Edge (1:1) ($K_e=0.2$)

Inlet Depression: None

Tailwater Data for Crossing: CD 25 Post

Table 4 - Downstream Channel Rating Curve (Crossing: CD 25 Post)

Flow (cfs)	Water Surface Elev (ft)	Depth (ft)
17.81	125.76	2.52
19.65	125.76	2.52
20.93	125.76	2.52
22.49	125.76	2.52
24.05	125.76	2.52
25.61	125.76	2.52
27.17	125.76	2.52
28.73	125.76	2.52
30.29	125.76	2.52
31.85	125.76	2.52
33.41	125.76	2.52

Tailwater Channel Data - CD 25 Post

Tailwater Channel Option: Enter Constant Tailwater Elevation

Constant Tailwater Elevation: 125.76 ft

Roadway Data for Crossing: CD 25 Post

Roadway Profile Shape: Constant Roadway Elevation

Crest Length: 1000.00 ft

Crest Elevation: 131.29 ft

Roadway Surface: Paved

Roadway Top Width: 130.00 ft

**APPENDIX E:
USDA NRCS**



United States
Department of
Agriculture

NRCS

Natural
Resources
Conservation
Service

A product of the National
Cooperative Soil Survey,
a joint effort of the United
States Department of
Agriculture and other
Federal agencies, State
agencies including the
Agricultural Experiment
Stations, and local
participants

Custom Soil Resource Report for **Polk County, Florida**

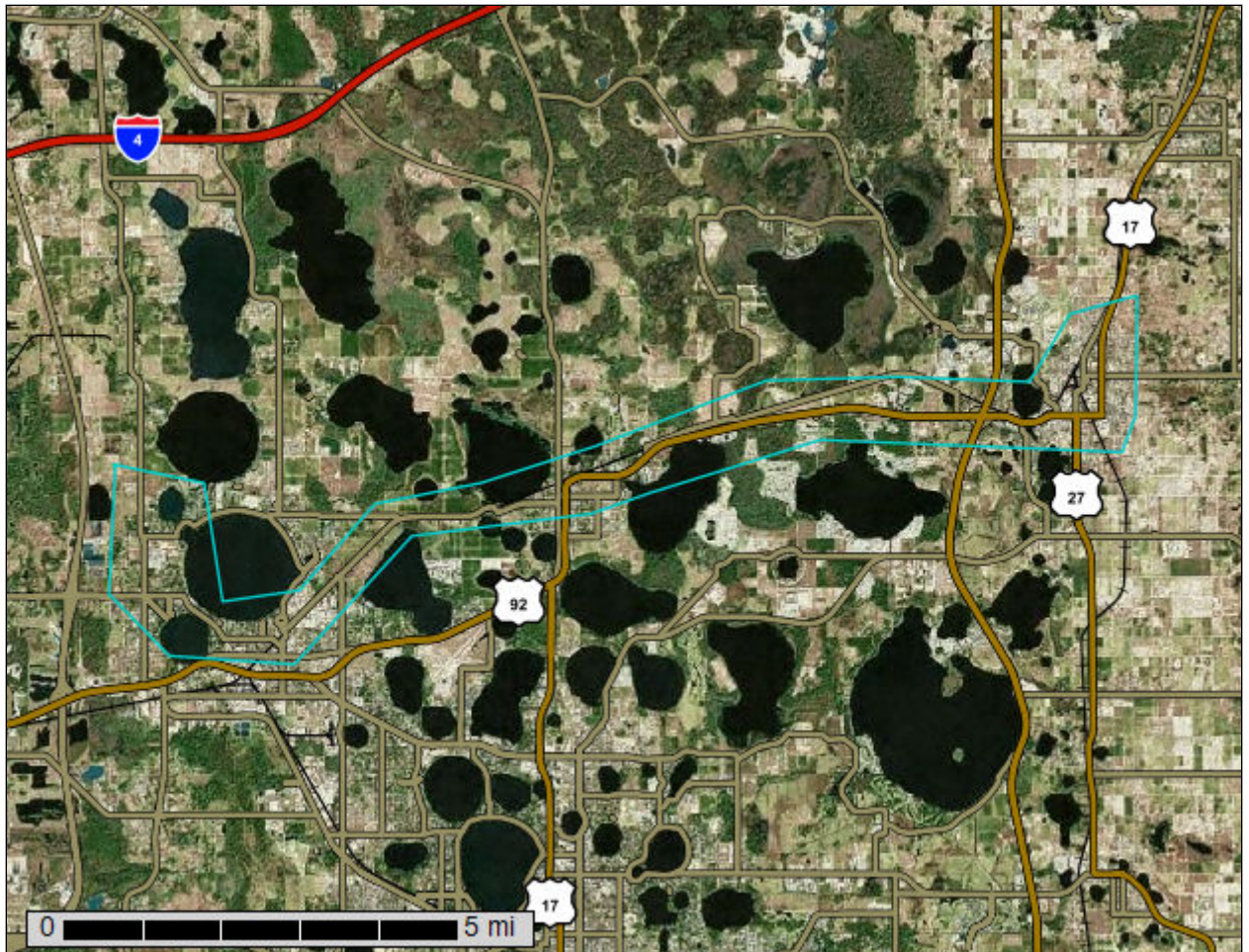

Preface

Soil surveys contain information that affects land use planning in survey areas. They highlight soil limitations that affect various land uses and provide information about the properties of the soils in the survey areas. Soil surveys are designed for many different users, including farmers, ranchers, foresters, agronomists, urban planners, community officials, engineers, developers, builders, and home buyers. Also, conservationists, teachers, students, and specialists in recreation, waste disposal, and pollution control can use the surveys to help them understand, protect, or enhance the environment.

Various land use regulations of Federal, State, and local governments may impose special restrictions on land use or land treatment. Soil surveys identify soil properties that are used in making various land use or land treatment decisions. The information is intended to help the land users identify and reduce the effects of soil limitations on various land uses. The landowner or user is responsible for identifying and complying with existing laws and regulations.

Although soil survey information can be used for general farm, local, and wider area planning, onsite investigation is needed to supplement this information in some cases. Examples include soil quality assessments (<http://www.nrcs.usda.gov/wps/portal/nrcs/main/soils/health/>) and certain conservation and engineering applications. For more detailed information, contact your local USDA Service Center (<https://offices.sc.egov.usda.gov/locator/app?agency=nrcs>) or your NRCS State Soil Scientist (http://www.nrcs.usda.gov/wps/portal/nrcs/detail/soils/contactus/?cid=nrcs142p2_053951).

Great differences in soil properties can occur within short distances. Some soils are seasonally wet or subject to flooding. Some are too unstable to be used as a foundation for buildings or roads. Clayey or wet soils are poorly suited to use as septic tank absorption fields. A high water table makes a soil poorly suited to basements or underground installations.

The National Cooperative Soil Survey is a joint effort of the United States Department of Agriculture and other Federal agencies, State agencies including the Agricultural Experiment Stations, and local agencies. The Natural Resources Conservation Service (NRCS) has leadership for the Federal part of the National Cooperative Soil Survey.

Information about soils is updated periodically. Updated information is available through the NRCS Web Soil Survey, the site for official soil survey information.

The U.S. Department of Agriculture (USDA) prohibits discrimination in all its programs and activities on the basis of race, color, national origin, age, disability, and where applicable, sex, marital status, familial status, parental status, religion, sexual orientation, genetic information, political beliefs, reprisal, or because all or a part of an individual's income is derived from any public assistance program. (Not all prohibited bases apply to all programs.) Persons with disabilities who require

alternative means for communication of program information (Braille, large print, audiotape, etc.) should contact USDA's TARGET Center at (202) 720-2600 (voice and TDD). To file a complaint of discrimination, write to USDA, Director, Office of Civil Rights, 1400 Independence Avenue, S.W., Washington, D.C. 20250-9410 or call (800) 795-3272 (voice) or (202) 720-6382 (TDD). USDA is an equal opportunity provider and employer.

Contents

Preface	2
How Soil Surveys Are Made	6
Soil Map	9
Soil Map.....	10
Legend.....	11
Map Unit Legend.....	12
Map Unit Descriptions.....	13
Polk County, Florida.....	15
2—Apopka fine sand, 0 to 5 percent slopes.....	15
3—Candler sand, 0 to 5 percent slopes.....	16
4—Candler sand, 5 to 8 percent slopes.....	18
7—Pomona fine sand.....	20
13—Samsula muck, frequently ponded, 0 to 1 percent slopes.....	22
14—Sparr sand, 0 to 5 percent slopes.....	25
15—Tavares fine sand, 0 to 5 percent slopes.....	26
16—Urban land, 0 to 2 percent slopes.....	28
17—Smyrna and Myakka fine sands.....	31
21—Immokalee sand.....	35
23—Ona-Ona, wet, fine sand, 0 to 2 percent slopes.....	37
25—Placid and Myakka fine sands, depressional.....	40
26—Lochloosa fine sand.....	42
27—Kendrick fine sand, 0 to 5 percent slopes.....	44
29—St. Lucie fine sand, 0 to 5 percent slopes.....	46
31—Adamsville fine sand, 0 to 2 percent slopes.....	48
33—Holopaw fine sand, frequently ponded, 0 to 1 percent slopes.....	49
35—Hontoon muck, frequently ponded, 0 to 1 percent slopes.....	51
36—Basinger mucky fine sand, frequently ponded, 0 to 1 percent slopes.....	53
40—Wauchula fine sand.....	55
42—Felda fine sand.....	58
47—Zolfo fine sand, 0 to 2 percent slopes.....	60
49—Adamsville-Urban land complex.....	62
50—Candler-Urban land complex, 0 to 5 percent slopes.....	64
51—Pomona-Urban land complex.....	65
53—Myakka-Immokolee-Urban land complex.....	68
55—Sparr-Urban land complex, 0 to 5 percent slopes.....	72
58—Udorthents, excavated.....	74
59—Arents-Urban land complex, 0 to 5 percent slopes.....	75
60—Arents, sandy.....	76
61—Arents, organic substratum-Urban land complex.....	77
63—Tavares-Urban land complex.....	78
66—Fort Meade-Urban land complex, 0 to 5 percent slopes.....	80
68—Arents, 0 to 5 percent slopes.....	81
76—Millhopper fine sand, 0 to 5 percent slopes.....	82

Custom Soil Resource Report

99—Water.....	84
References	85

How Soil Surveys Are Made

Soil surveys are made to provide information about the soils and miscellaneous areas in a specific area. They include a description of the soils and miscellaneous areas and their location on the landscape and tables that show soil properties and limitations affecting various uses. Soil scientists observed the steepness, length, and shape of the slopes; the general pattern of drainage; the kinds of crops and native plants; and the kinds of bedrock. They observed and described many soil profiles. A soil profile is the sequence of natural layers, or horizons, in a soil. The profile extends from the surface down into the unconsolidated material in which the soil formed or from the surface down to bedrock. The unconsolidated material is devoid of roots and other living organisms and has not been changed by other biological activity.

Currently, soils are mapped according to the boundaries of major land resource areas (MLRAs). MLRAs are geographically associated land resource units that share common characteristics related to physiography, geology, climate, water resources, soils, biological resources, and land uses (USDA, 2006). Soil survey areas typically consist of parts of one or more MLRA.

The soils and miscellaneous areas in a survey area occur in an orderly pattern that is related to the geology, landforms, relief, climate, and natural vegetation of the area. Each kind of soil and miscellaneous area is associated with a particular kind of landform or with a segment of the landform. By observing the soils and miscellaneous areas in the survey area and relating their position to specific segments of the landform, a soil scientist develops a concept, or model, of how they were formed. Thus, during mapping, this model enables the soil scientist to predict with a considerable degree of accuracy the kind of soil or miscellaneous area at a specific location on the landscape.

Commonly, individual soils on the landscape merge into one another as their characteristics gradually change. To construct an accurate soil map, however, soil scientists must determine the boundaries between the soils. They can observe only a limited number of soil profiles. Nevertheless, these observations, supplemented by an understanding of the soil-vegetation-landscape relationship, are sufficient to verify predictions of the kinds of soil in an area and to determine the boundaries.

Soil scientists recorded the characteristics of the soil profiles that they studied. They noted soil color, texture, size and shape of soil aggregates, kind and amount of rock fragments, distribution of plant roots, reaction, and other features that enable them to identify soils. After describing the soils in the survey area and determining their properties, the soil scientists assigned the soils to taxonomic classes (units). Taxonomic classes are concepts. Each taxonomic class has a set of soil characteristics with precisely defined limits. The classes are used as a basis for comparison to classify soils systematically. Soil taxonomy, the system of taxonomic classification used in the United States, is based mainly on the kind and character of soil properties and the arrangement of horizons within the profile. After the soil

Custom Soil Resource Report

scientists classified and named the soils in the survey area, they compared the individual soils with similar soils in the same taxonomic class in other areas so that they could confirm data and assemble additional data based on experience and research.

The objective of soil mapping is not to delineate pure map unit components; the objective is to separate the landscape into landforms or landform segments that have similar use and management requirements. Each map unit is defined by a unique combination of soil components and/or miscellaneous areas in predictable proportions. Some components may be highly contrasting to the other components of the map unit. The presence of minor components in a map unit in no way diminishes the usefulness or accuracy of the data. The delineation of such landforms and landform segments on the map provides sufficient information for the development of resource plans. If intensive use of small areas is planned, onsite investigation is needed to define and locate the soils and miscellaneous areas.

Soil scientists make many field observations in the process of producing a soil map. The frequency of observation is dependent upon several factors, including scale of mapping, intensity of mapping, design of map units, complexity of the landscape, and experience of the soil scientist. Observations are made to test and refine the soil-landscape model and predictions and to verify the classification of the soils at specific locations. Once the soil-landscape model is refined, a significantly smaller number of measurements of individual soil properties are made and recorded. These measurements may include field measurements, such as those for color, depth to bedrock, and texture, and laboratory measurements, such as those for content of sand, silt, clay, salt, and other components. Properties of each soil typically vary from one point to another across the landscape.

Observations for map unit components are aggregated to develop ranges of characteristics for the components. The aggregated values are presented. Direct measurements do not exist for every property presented for every map unit component. Values for some properties are estimated from combinations of other properties.

While a soil survey is in progress, samples of some of the soils in the area generally are collected for laboratory analyses and for engineering tests. Soil scientists interpret the data from these analyses and tests as well as the field-observed characteristics and the soil properties to determine the expected behavior of the soils under different uses. Interpretations for all of the soils are field tested through observation of the soils in different uses and under different levels of management. Some interpretations are modified to fit local conditions, and some new interpretations are developed to meet local needs. Data are assembled from other sources, such as research information, production records, and field experience of specialists. For example, data on crop yields under defined levels of management are assembled from farm records and from field or plot experiments on the same kinds of soil.

Predictions about soil behavior are based not only on soil properties but also on such variables as climate and biological activity. Soil conditions are predictable over long periods of time, but they are not predictable from year to year. For example, soil scientists can predict with a fairly high degree of accuracy that a given soil will have a high water table within certain depths in most years, but they cannot predict that a high water table will always be at a specific level in the soil on a specific date.

After soil scientists located and identified the significant natural bodies of soil in the survey area, they drew the boundaries of these bodies on aerial photographs and

Custom Soil Resource Report

identified each as a specific map unit. Aerial photographs show trees, buildings, fields, roads, and rivers, all of which help in locating boundaries accurately.

Soil Map

The soil map section includes the soil map for the defined area of interest, a list of soil map units on the map and extent of each map unit, and cartographic symbols displayed on the map. Also presented are various metadata about data used to produce the map, and a description of each soil map unit.

Custom Soil Resource Report
Soil Map

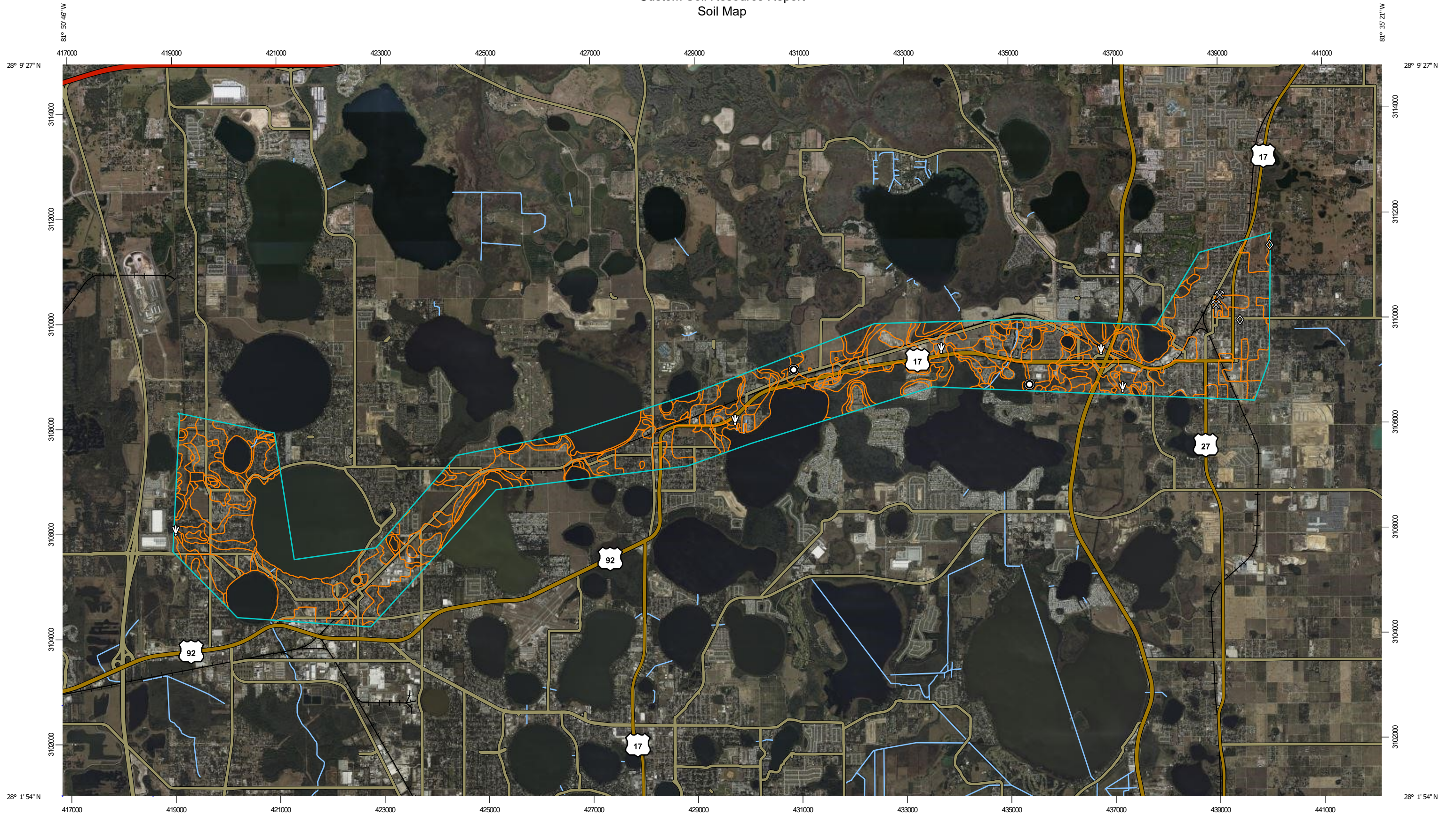

Map Scale: 1:68,000 if printed on B landscape (17" x 11") sheet.



Map projection: Web Mercator Corner coordinates: WGS84 Edge tics: UTM Zone 17N WGS84

MAP LEGEND

Area of Interest (AOI)

 Area of Interest (AOI)



















Soils

 Soil Map Unit Polygons

 Soil Map Unit Lines

 Soil Map Unit Points

Special Point Features





-  Blowout
-  Borrow Pit
-  Clay Spot
-  Closed Depression
-  Gravel Pit
-  Gravelly Spot
-  Landfill
-  Lava Flow
-  Marsh or swamp
-  Mine or Quarry
-  Miscellaneous Water
-  Perennial Water
-  Rock Outcrop
-  Saline Spot
-  Sandy Spot
-  Severely Eroded Spot
-  Sinkhole
-  Slide or Slip
-  Sodic Spot

-  Spoil Area
-  Stony Spot
-  Very Stony Spot
-  Wet Spot
-  Other
-  Special Line Features

Water Features

 Streams and Canals

Transportation

-  Rails
-  Interstate Highways
-  US Routes
-  Major Roads
-  Local Roads

Background

 Aerial Photography

MAP INFORMATION

The soil surveys that comprise your AOI were mapped at 1:20,000.

Please rely on the bar scale on each map sheet for map measurements.

Source of Map: Natural Resources Conservation Service
 Web Soil Survey URL:
 Coordinate System: Web Mercator (EPSG:3857)

Maps from the Web Soil Survey are based on the Web Mercator projection, which preserves direction and shape but distorts distance and area. A projection that preserves area, such as the Albers equal-area conic projection, should be used if more accurate calculations of distance or area are required.

This product is generated from the USDA-NRCS certified data as of the version date(s) listed below.

Soil Survey Area: Polk County, Florida
 Survey Area Data: Version 21, Sep 6, 2023

Soil map units are labeled (as space allows) for map scales 1:50,000 or larger.

Date(s) aerial images were photographed: Nov 25, 2020—Mar 21, 2022

The orthophoto or other base map on which the soil lines were compiled and digitized probably differs from the background imagery displayed on these maps. As a result, some minor shifting of map unit boundaries may be evident.

Map Unit Legend

Map Unit Symbol	Map Unit Name	Acres in AOI	Percent of AOI
2	Apopka fine sand, 0 to 5 percent slopes	109.2	1.3%
3	Candler sand, 0 to 5 percent slopes	1,482.2	17.5%
4	Candler sand, 5 to 8 percent slopes	7.9	0.1%
7	Pomona fine sand	92.5	1.1%
13	Samsula muck, frequently ponded, 0 to 1 percent slopes	248.4	2.9%
14	Sparr sand, 0 to 5 percent slopes	123.0	1.5%
15	Tavares fine sand, 0 to 5 percent slopes	654.6	7.7%
16	Urban land, 0 to 2 percent slopes	414.5	4.9%
17	Smyrna and Myakka fine sands	269.7	3.2%
21	Immokalee sand	48.4	0.6%
23	Ona-Ona, wet, fine sand, 0 to 2 percent slopes	37.5	0.4%
25	Placid and Myakka fine sands, depressional	120.0	1.4%
26	Lochloosa fine sand	4.4	0.1%
27	Kendrick fine sand, 0 to 5 percent slopes	17.8	0.2%
29	St. Lucie fine sand, 0 to 5 percent slopes	24.7	0.3%
31	Adamsville fine sand, 0 to 2 percent slopes	508.8	6.0%
33	Holopaw fine sand, frequently ponded, 0 to 1 percent slopes	12.2	0.1%
35	Hontoon muck, frequently ponded, 0 to 1 percent slopes	554.2	6.6%
36	Basinger mucky fine sand, frequently ponded, 0 to 1 percent slopes	75.3	0.9%
40	Wauchula fine sand	1.3	0.0%
42	Felda fine sand	10.2	0.1%
47	Zolfo fine sand, 0 to 2 percent slopes	34.0	0.4%
49	Adamsville-Urban land complex	158.5	1.9%
50	Candler-Urban land complex, 0 to 5 percent slopes	1,235.3	14.6%
51	Pomona-Urban land complex	73.3	0.9%

Custom Soil Resource Report

Map Unit Symbol	Map Unit Name	Acres in AOI	Percent of AOI
53	Myakka-Immokolee-Urban land complex	125.1	1.5%
55	Sparr-Urban land complex, 0 to 5 percent slopes	5.5	0.1%
58	Udorthents, excavated	49.5	0.6%
59	Arents-Urban land complex, 0 to 5 percent slopes	45.4	0.5%
60	Arents, sandy	10.3	0.1%
61	Arents, organic substratum-Urban land complex	30.8	0.4%
63	Tavares-Urban land complex	305.1	3.6%
66	Fort Meade-Urban land complex, 0 to 5 percent slopes	7.6	0.1%
68	Arents, 0 to 5 percent slopes	12.8	0.2%
76	Millhopper fine sand, 0 to 5 percent slopes	170.2	2.0%
99	Water	1,367.2	16.2%
Totals for Area of Interest		8,447.5	100.0%

Map Unit Descriptions

The map units delineated on the detailed soil maps in a soil survey represent the soils or miscellaneous areas in the survey area. The map unit descriptions, along with the maps, can be used to determine the composition and properties of a unit.

A map unit delineation on a soil map represents an area dominated by one or more major kinds of soil or miscellaneous areas. A map unit is identified and named according to the taxonomic classification of the dominant soils. Within a taxonomic class there are precisely defined limits for the properties of the soils. On the landscape, however, the soils are natural phenomena, and they have the characteristic variability of all natural phenomena. Thus, the range of some observed properties may extend beyond the limits defined for a taxonomic class. Areas of soils of a single taxonomic class rarely, if ever, can be mapped without including areas of other taxonomic classes. Consequently, every map unit is made up of the soils or miscellaneous areas for which it is named and some minor components that belong to taxonomic classes other than those of the major soils.

Most minor soils have properties similar to those of the dominant soil or soils in the map unit, and thus they do not affect use and management. These are called noncontrasting, or similar, components. They may or may not be mentioned in a particular map unit description. Other minor components, however, have properties and behavioral characteristics divergent enough to affect use or to require different management. These are called contrasting, or dissimilar, components. They generally are in small areas and could not be mapped separately because of the scale used. Some small areas of strongly contrasting soils or miscellaneous areas are identified by a special symbol on the maps. If included in the database for a given area, the contrasting minor components are identified in the map unit

Custom Soil Resource Report

descriptions along with some characteristics of each. A few areas of minor components may not have been observed, and consequently they are not mentioned in the descriptions, especially where the pattern was so complex that it was impractical to make enough observations to identify all the soils and miscellaneous areas on the landscape.

The presence of minor components in a map unit in no way diminishes the usefulness or accuracy of the data. The objective of mapping is not to delineate pure taxonomic classes but rather to separate the landscape into landforms or landform segments that have similar use and management requirements. The delineation of such segments on the map provides sufficient information for the development of resource plans. If intensive use of small areas is planned, however, onsite investigation is needed to define and locate the soils and miscellaneous areas.

An identifying symbol precedes the map unit name in the map unit descriptions. Each description includes general facts about the unit and gives important soil properties and qualities.

Soils that have profiles that are almost alike make up a *soil series*. Except for differences in texture of the surface layer, all the soils of a series have major horizons that are similar in composition, thickness, and arrangement.

Soils of one series can differ in texture of the surface layer, slope, stoniness, salinity, degree of erosion, and other characteristics that affect their use. On the basis of such differences, a soil series is divided into *soil phases*. Most of the areas shown on the detailed soil maps are phases of soil series. The name of a soil phase commonly indicates a feature that affects use or management. For example, Alpha silt loam, 0 to 2 percent slopes, is a phase of the Alpha series.

Some map units are made up of two or more major soils or miscellaneous areas. These map units are complexes, associations, or undifferentiated groups.

A *complex* consists of two or more soils or miscellaneous areas in such an intricate pattern or in such small areas that they cannot be shown separately on the maps. The pattern and proportion of the soils or miscellaneous areas are somewhat similar in all areas. Alpha-Beta complex, 0 to 6 percent slopes, is an example.

An *association* is made up of two or more geographically associated soils or miscellaneous areas that are shown as one unit on the maps. Because of present or anticipated uses of the map units in the survey area, it was not considered practical or necessary to map the soils or miscellaneous areas separately. The pattern and relative proportion of the soils or miscellaneous areas are somewhat similar. Alpha-Beta association, 0 to 2 percent slopes, is an example.

An *undifferentiated group* is made up of two or more soils or miscellaneous areas that could be mapped individually but are mapped as one unit because similar interpretations can be made for use and management. The pattern and proportion of the soils or miscellaneous areas in a mapped area are not uniform. An area can be made up of only one of the major soils or miscellaneous areas, or it can be made up of all of them. Alpha and Beta soils, 0 to 2 percent slopes, is an example.

Some surveys include *miscellaneous areas*. Such areas have little or no soil material and support little or no vegetation. Rock outcrop is an example.

Polk County, Florida

2—Apopka fine sand, 0 to 5 percent slopes

Map Unit Setting

National map unit symbol: 2shkg
Elevation: 10 to 260 feet
Mean annual precipitation: 45 to 56 inches
Mean annual air temperature: 66 to 75 degrees F
Frost-free period: 287 to 365 days
Farmland classification: Farmland of unique importance

Map Unit Composition

Apopka and similar soils: 85 percent
Minor components: 15 percent
Estimates are based on observations, descriptions, and transects of the mapunit.

Description of Apopka

Setting

Landform: Ridges on marine terraces, knolls on marine terraces
Landform position (two-dimensional): Summit, shoulder, footslope
Landform position (three-dimensional): Crest, side slope, nose slope
Down-slope shape: Convex
Across-slope shape: Linear
Parent material: Eolian or sandy marine deposits over loamy marine deposits

Typical profile

A - 0 to 7 inches: fine sand
E - 7 to 50 inches: fine sand
Bt1 - 50 to 67 inches: fine sandy loam
Bt2 - 67 to 80 inches: sandy clay loam

Properties and qualities

Slope: 0 to 5 percent
Depth to restrictive feature: More than 80 inches
Drainage class: Well drained
Runoff class: Very low
Capacity of the most limiting layer to transmit water (Ksat): Moderately high to high
(0.20 to 2.00 in/hr)
Depth to water table: More than 80 inches
Frequency of flooding: None
Frequency of ponding: None
Maximum salinity: Nonsaline to very slightly saline (0.0 to 2.0 mmhos/cm)
Sodium adsorption ratio, maximum: 12.0
Available water supply, 0 to 60 inches: Low (about 5.1 inches)

Interpretive groups

Land capability classification (irrigated): None specified
Land capability classification (nonirrigated): 3s
Hydrologic Soil Group: A
Forage suitability group: Sandy soils on ridges and dunes of xeric uplands
(G154XB111FL)
Other vegetative classification: Sandy soils on ridges and dunes of xeric uplands
(G154XB111FL), Longleaf Pine-Turkey Oak Hills (R154XY002FL)

Custom Soil Resource Report

Hydric soil rating: No

Minor Components

Candler

Percent of map unit: 5 percent

Landform: Knolls on marine terraces, ridges on marine terraces

Landform position (two-dimensional): Summit

Landform position (three-dimensional): Interfluve, tread

Down-slope shape: Linear, convex

Across-slope shape: Linear, convex, concave

Other vegetative classification: Sandy soils on ridges and dunes of xeric uplands (G155XB111FL), Longleaf Pine-Turkey Oak Hills (R154XY002FL)

Hydric soil rating: No

Tavares

Percent of map unit: 5 percent

Landform: Knolls on marine terraces, ridges on marine terraces

Landform position (three-dimensional): Interfluve

Down-slope shape: Convex

Across-slope shape: Linear

Other vegetative classification: Sandy soils on rises, knolls, and ridges of mesic uplands (G154XB121FL), Longleaf Pine-Turkey Oak Hills (R154XY002FL)

Hydric soil rating: No

Sparr

Percent of map unit: 5 percent

Landform: Flats on marine terraces, rises on marine terraces

Landform position (three-dimensional): Interfluve, rise

Down-slope shape: Convex

Across-slope shape: Linear

Other vegetative classification: Sandy soils on rises and knolls of mesic uplands (G154XB131FL), Upland Hardwood Hammock (R154XY008FL)

Hydric soil rating: No

3—Candler sand, 0 to 5 percent slopes

Map Unit Setting

National map unit symbol: 2t3z1

Elevation: 10 to 260 feet

Mean annual precipitation: 47 to 56 inches

Mean annual air temperature: 68 to 77 degrees F

Frost-free period: 280 to 365 days

Farmland classification: Farmland of unique importance

Map Unit Composition

Candler and similar soils: 90 percent

Minor components: 10 percent

Estimates are based on observations, descriptions, and transects of the mapunit.

Description of Candler

Setting

Landform: Knolls on marine terraces, ridges on marine terraces
Landform position (two-dimensional): Backslope
Landform position (three-dimensional): Side slope, interfluve, tread
Down-slope shape: Convex
Across-slope shape: Convex
Parent material: Eolian deposits and/or sandy and loamy marine deposits

Typical profile

A - 0 to 6 inches: sand
E - 6 to 63 inches: sand
E and Bt - 63 to 80 inches: sand

Properties and qualities

Slope: 0 to 5 percent
Depth to restrictive feature: More than 80 inches
Drainage class: Excessively drained
Runoff class: Negligible
Capacity of the most limiting layer to transmit water (Ksat): High to very high (5.95 to 19.98 in/hr)
Depth to water table: More than 80 inches
Frequency of flooding: None
Frequency of ponding: None
Maximum salinity: Nonsaline to very slightly saline (0.0 to 2.0 mmhos/cm)
Sodium adsorption ratio, maximum: 4.0
Available water supply, 0 to 60 inches: Very low (about 2.5 inches)

Interpretive groups

Land capability classification (irrigated): None specified
Land capability classification (nonirrigated): 4s
Hydrologic Soil Group: A
Forage suitability group: Sandy soils on ridges and dunes of xeric uplands (G154XB111FL), Sandy soils on ridges and dunes of xeric uplands (G155XB111FL)
Other vegetative classification: Sandy soils on ridges and dunes of xeric uplands (G154XB111FL), Longleaf Pine-Turkey Oak Hills (R154XY002FL), Longleaf Pine-Turkey Oak Hills (R155XY002FL), Sandy soils on ridges and dunes of xeric uplands (G155XB111FL)
Hydric soil rating: No

Minor Components

Tavares

Percent of map unit: 5 percent
Landform: Ridges on marine terraces
Landform position (two-dimensional): Footslope, toeslope
Landform position (three-dimensional): Interfluve
Down-slope shape: Concave, convex
Across-slope shape: Linear
Other vegetative classification: Sandy soils on rises, knolls, and ridges of mesic uplands (G154XB121FL), Longleaf Pine-Turkey Oak Hills (R154XY002FL)
Hydric soil rating: No

Millhopper

Percent of map unit: 5 percent

Landform: Ridges on marine terraces

Landform position (two-dimensional): Backslope

Landform position (three-dimensional): Interfluve

Down-slope shape: Convex

Across-slope shape: Linear

Other vegetative classification: Sandy soils on rises, knolls, and ridges of mesic uplands (G154XB121FL), Longleaf Pine-Turkey Oak Hills (R154XY002FL)

Hydric soil rating: No

4—Candler sand, 5 to 8 percent slopes

Map Unit Setting

National map unit symbol: 1jttm

Elevation: 20 to 150 feet

Mean annual precipitation: 46 to 54 inches

Mean annual air temperature: 70 to 77 degrees F

Frost-free period: 350 to 365 days

Farmland classification: Farmland of unique importance

Map Unit Composition

Candler and similar soils: 85 percent

Minor components: 15 percent

Estimates are based on observations, descriptions, and transects of the mapunit.

Description of Candler

Setting

Landform: Knolls on marine terraces, hillslopes on marine terraces

Landform position (three-dimensional): Interfluve

Down-slope shape: Convex

Across-slope shape: Convex

Parent material: Eolian deposits and/or sandy and loamy marine deposits

Typical profile

A - 0 to 7 inches: sand

E - 7 to 63 inches: sand

E and Bt - 63 to 80 inches: sand

Properties and qualities

Slope: 5 to 8 percent

Depth to restrictive feature: More than 80 inches

Drainage class: Excessively drained

Runoff class: Very low

Capacity of the most limiting layer to transmit water (Ksat): High to very high (5.95 to 19.98 in/hr)

Depth to water table: More than 80 inches

Frequency of flooding: None

Frequency of ponding: None

Custom Soil Resource Report

Maximum salinity: Nonsaline to very slightly saline (0.0 to 2.0 mmhos/cm)
Sodium adsorption ratio, maximum: 4.0
Available water supply, 0 to 60 inches: Very low (about 2.5 inches)

Interpretive groups

Land capability classification (irrigated): None specified
Land capability classification (nonirrigated): 6s
Hydrologic Soil Group: A
Forage suitability group: Sandy soils on ridges and dunes of xeric uplands (G154XB111FL)
Other vegetative classification: Sandy soils on ridges and dunes of xeric uplands (G154XB111FL), Longleaf Pine-Turkey Oak Hills (R154XY002FL)
Hydric soil rating: No

Minor Components

Astatula

Percent of map unit: 4 percent
Landform: Hills on marine terraces, ridges on marine terraces
Landform position (three-dimensional): Interfluve, side slope
Down-slope shape: Convex
Across-slope shape: Convex
Other vegetative classification: Sandy soils on ridges and dunes of xeric uplands (G154XB111FL), Longleaf Pine-Turkey Oak Hills (R154XY002FL)
Hydric soil rating: No

Millhopper

Percent of map unit: 4 percent
Landform: Knolls on marine terraces, ridges on marine terraces
Landform position (three-dimensional): Interfluve
Down-slope shape: Convex
Across-slope shape: Linear
Other vegetative classification: Sandy soils on rises, knolls, and ridges of mesic uplands (G154XB121FL), Upland Hardwood Hammock (R154XY008FL)
Hydric soil rating: No

Apopka

Percent of map unit: 4 percent
Landform: Knolls on marine terraces, ridges on marine terraces
Landform position (three-dimensional): Interfluve, side slope
Down-slope shape: Convex
Across-slope shape: Linear
Other vegetative classification: Sandy soils on ridges and dunes of xeric uplands (G154XB111FL), Longleaf Pine-Turkey Oak Hills (R154XY002FL)
Hydric soil rating: No

Tavares

Percent of map unit: 3 percent
Landform: Knolls on marine terraces, ridges on marine terraces
Landform position (three-dimensional): Interfluve
Down-slope shape: Convex
Across-slope shape: Linear
Other vegetative classification: Sandy soils on rises, knolls, and ridges of mesic uplands (G154XB121FL), Longleaf Pine-Turkey Oak Hills (R154XY002FL)
Hydric soil rating: No

7—Pomona fine sand

Map Unit Setting

National map unit symbol: 1jttq
Elevation: 20 to 120 feet
Mean annual precipitation: 46 to 54 inches
Mean annual air temperature: 70 to 77 degrees F
Frost-free period: 350 to 365 days
Farmland classification: Not prime farmland

Map Unit Composition

Pomona, non-hydric, and similar soils: 70 percent
Pomona, hydric, and similar soils: 20 percent
Minor components: 10 percent
Estimates are based on observations, descriptions, and transects of the mapunit.

Description of Pomona, Non-hydric

Setting

Landform: Flatwoods on marine terraces
Landform position (three-dimensional): Talf
Down-slope shape: Convex
Across-slope shape: Linear
Parent material: Sandy and loamy marine deposits

Typical profile

A - 0 to 6 inches: fine sand
E - 6 to 21 inches: sand
Bh - 21 to 26 inches: fine sand
E' - 26 to 48 inches: fine sand
Btg - 48 to 73 inches: fine sandy loam
Cg - 73 to 80 inches: loamy sand

Properties and qualities

Slope: 0 to 2 percent
Depth to restrictive feature: More than 80 inches
Drainage class: Poorly drained
Runoff class: High
Capacity of the most limiting layer to transmit water (Ksat): Moderately high to high
(0.20 to 1.98 in/hr)
Depth to water table: About 6 to 18 inches
Frequency of flooding: None
Frequency of ponding: None
Maximum salinity: Nonsaline to very slightly saline (0.0 to 2.0 mmhos/cm)
Sodium adsorption ratio, maximum: 4.0
Available water supply, 0 to 60 inches: Low (about 5.7 inches)

Interpretive groups

Land capability classification (irrigated): None specified
Land capability classification (nonirrigated): 4w

Custom Soil Resource Report

Hydrologic Soil Group: A/D

Ecological site: F155XY120FL - Sandy Flatwoods and Hammocks

Forage suitability group: Sandy soils on flats of mesic or hydric lowlands (G154XB141FL)

Other vegetative classification: Sandy soils on flats of mesic or hydric lowlands (G154XB141FL), South Florida Flatwoods (R154XY003FL)

Hydric soil rating: No

Description of Pomona, Hydric

Setting

Landform: Flats on marine terraces

Landform position (three-dimensional): Talf

Down-slope shape: Linear

Across-slope shape: Linear

Parent material: Sandy and loamy marine deposits

Typical profile

A - 0 to 6 inches: fine sand

E - 6 to 21 inches: sand

Bh - 21 to 26 inches: fine sand

E' - 26 to 48 inches: fine sand

Btg - 48 to 73 inches: fine sandy loam

Cg - 73 to 80 inches: loamy sand

Properties and qualities

Slope: 0 to 2 percent

Depth to restrictive feature: More than 80 inches

Drainage class: Poorly drained

Runoff class: High

Capacity of the most limiting layer to transmit water (Ksat): Moderately high to high (0.20 to 1.98 in/hr)

Depth to water table: About 0 to 12 inches

Frequency of flooding: None

Frequency of ponding: None

Maximum salinity: Nonsaline to very slightly saline (0.0 to 2.0 mmhos/cm)

Sodium adsorption ratio, maximum: 4.0

Available water supply, 0 to 60 inches: Low (about 5.7 inches)

Interpretive groups

Land capability classification (irrigated): None specified

Land capability classification (nonirrigated): 4w

Hydrologic Soil Group: A/D

Ecological site: F155XY120FL - Sandy Flatwoods and Hammocks

Forage suitability group: Sandy soils on flats of mesic or hydric lowlands (G154XB141FL)

Other vegetative classification: Sandy soils on flats of mesic or hydric lowlands (G154XB141FL), South Florida Flatwoods (R154XY003FL)

Hydric soil rating: Yes

Minor Components

Myakka

Percent of map unit: 4 percent

Landform: Flatwoods on marine terraces

Landform position (three-dimensional): Talf

Down-slope shape: Convex

Custom Soil Resource Report

Across-slope shape: Linear

Ecological site: F155XY120FL - Sandy Flatwoods and Hammocks

Other vegetative classification: Sandy soils on flats of mesic or hydric lowlands (G154XB141FL), South Florida Flatwoods (R154XY003FL)

Hydric soil rating: No

Smyrna, non-hydric

Percent of map unit: 3 percent

Landform: Flats on marine terraces

Landform position (three-dimensional): Talf

Down-slope shape: Convex

Across-slope shape: Linear

Ecological site: F155XY120FL - Sandy Flatwoods and Hammocks

Other vegetative classification: Sandy soils on flats of mesic or hydric lowlands (G154XB141FL), South Florida Flatwoods (R154XY003FL)

Hydric soil rating: No

Wauchula, non-hydric

Percent of map unit: 3 percent

Landform: Flatwoods on marine terraces

Landform position (three-dimensional): Talf

Down-slope shape: Convex

Across-slope shape: Linear

Ecological site: F155XY130FL - Sandy over Loamy Flatwoods and Hammocks

Other vegetative classification: Sandy over loamy soils on flats of hydric or mesic lowlands (G154XB241FL), South Florida Flatwoods (R154XY003FL)

Hydric soil rating: No

13—Samsula muck, frequently ponded, 0 to 1 percent slopes

Map Unit Setting

National map unit symbol: 2tzw9

Elevation: 0 to 250 feet

Mean annual precipitation: 44 to 63 inches

Mean annual air temperature: 68 to 77 degrees F

Frost-free period: 335 to 365 days

Farmland classification: Not prime farmland

Map Unit Composition

Samsula and similar soils: 85 percent

Minor components: 15 percent

Estimates are based on observations, descriptions, and transects of the mapunit.

Description of Samsula

Setting

Landform: Depressions on marine terraces

Landform position (three-dimensional): Tread, dip

Down-slope shape: Concave

Custom Soil Resource Report

Across-slope shape: Concave

Parent material: Herbaceous organic material over sandy marine deposits

Typical profile

Oa1 - 0 to 24 inches: muck

Oa2 - 24 to 32 inches: muck

Cg1 - 32 to 35 inches: sand

Cg2 - 35 to 44 inches: sand

Cg3 - 44 to 80 inches: sand

Properties and qualities

Slope: 0 to 1 percent

Depth to restrictive feature: More than 80 inches

Drainage class: Very poorly drained

Runoff class: Negligible

Capacity of the most limiting layer to transmit water (Ksat): High to very high (5.95 to 19.98 in/hr)

Depth to water table: About 0 inches

Frequency of flooding: None

Frequency of ponding: Frequent

Maximum salinity: Nonsaline to very slightly saline (0.0 to 2.0 mmhos/cm)

Sodium adsorption ratio, maximum: 4.0

Available water supply, 0 to 60 inches: Very high (about 13.9 inches)

Interpretive groups

Land capability classification (irrigated): None specified

Land capability classification (nonirrigated): 7w

Hydrologic Soil Group: A/D

Ecological site: R155XY100FL - Organic Freshwater Isolated Marshes and Swamps

Forage suitability group: Organic soils in depressions and on flood plains (G155XB645FL)

Other vegetative classification: Organic soils in depressions and on flood plains (G155XB645FL), Freshwater Marshes and Ponds (R155XY010FL)

Hydric soil rating: Yes

Minor Components

Myakka

Percent of map unit: 3 percent

Landform: Depressions on marine terraces

Landform position (three-dimensional): Tread, dip

Down-slope shape: Linear, concave

Across-slope shape: Linear, concave

Ecological site: R155XY070FL - Sandy Freshwater Isolated Marshes and Swamps

Other vegetative classification: Sandy soils on stream terraces, flood plains, or in depressions (G155XB145FL), Freshwater Marshes and Ponds (R155XY010FL)

Hydric soil rating: Yes

Kaliga

Percent of map unit: 3 percent

Landform: Depressions on flatwoods on marine terraces

Landform position (three-dimensional): Tread, dip, talf

Down-slope shape: Linear, concave

Across-slope shape: Linear, concave

Custom Soil Resource Report

Ecological site: R155XY100FL - Organic Freshwater Isolated Marshes and Swamps

Other vegetative classification: Organic soils in depressions and on flood plains (G155XB645FL), Freshwater Marshes and Ponds (R155XY010FL)

Hydric soil rating: Yes

Basinger

Percent of map unit: 3 percent

Landform: Depressions on marine terraces

Landform position (three-dimensional): Tread, dip

Down-slope shape: Concave, linear

Across-slope shape: Concave, linear

Ecological site: R155XY070FL - Sandy Freshwater Isolated Marshes and Swamps

Other vegetative classification: Sandy soils on flats of mesic or hydric lowlands (G155XB141FL)

Hydric soil rating: Yes

Anclote

Percent of map unit: 2 percent

Landform: Depressions on marine terraces

Landform position (three-dimensional): Tread, dip

Down-slope shape: Convex, concave

Across-slope shape: Linear, concave

Ecological site: R155XY070FL - Sandy Freshwater Isolated Marshes and Swamps

Other vegetative classification: Sandy soils on stream terraces, flood plains, or in depressions (G155XB145FL)

Hydric soil rating: Yes

Floridana

Percent of map unit: 2 percent

Landform: Depressions on marine terraces

Landform position (three-dimensional): Tread, dip

Down-slope shape: Concave, linear

Across-slope shape: Concave, linear

Ecological site: R155XY080FL - Sandy over Loamy Freshwater Isolated Marshes and Swamps

Other vegetative classification: Sandy over loamy soils on stream terraces, flood plains, or in depressions (G155XB245FL), Freshwater Marshes and Ponds (R155XY010FL)

Hydric soil rating: Yes

Sanibel

Percent of map unit: 2 percent

Landform: Depressions on marine terraces

Landform position (three-dimensional): Tread, dip

Down-slope shape: Linear, concave

Across-slope shape: Concave

Ecological site: R155XY100FL - Organic Freshwater Isolated Marshes and Swamps

Other vegetative classification: Organic soils in depressions and on flood plains (G155XB645FL)

Hydric soil rating: Yes

14—Sparr sand, 0 to 5 percent slopes

Map Unit Setting

National map unit symbol: 2w0q9
Elevation: 40 to 150 feet
Mean annual precipitation: 44 to 56 inches
Mean annual air temperature: 68 to 77 degrees F
Frost-free period: 290 to 365 days
Farmland classification: Farmland of unique importance

Map Unit Composition

Sparr and similar soils: 85 percent
Minor components: 15 percent
Estimates are based on observations, descriptions, and transects of the mapunit.

Description of Sparr

Setting

Landform: Knolls on marine terraces, rises on marine terraces
Landform position (two-dimensional): Backslope
Landform position (three-dimensional): Interfluve, tread, rise
Down-slope shape: Linear, convex
Across-slope shape: Convex, linear
Parent material: Sandy marine deposits and/or loamy marine deposits

Typical profile

A - 0 to 8 inches: sand
E - 8 to 57 inches: sand
Bt - 57 to 80 inches: sandy clay loam

Properties and qualities

Slope: 0 to 5 percent
Depth to restrictive feature: More than 80 inches
Drainage class: Somewhat poorly drained
Runoff class: Low
Capacity of the most limiting layer to transmit water (Ksat): Moderately high to high
(0.57 to 1.98 in/hr)
Depth to water table: About 18 to 42 inches
Frequency of flooding: None
Frequency of ponding: None
Maximum salinity: Nonsaline to very slightly saline (0.0 to 2.0 mmhos/cm)
Sodium adsorption ratio, maximum: 4.0
Available water supply, 0 to 60 inches: Low (about 4.6 inches)

Interpretive groups

Land capability classification (irrigated): None specified
Land capability classification (nonirrigated): 3w
Hydrologic Soil Group: A/D
Forage suitability group: Sandy soils on rises and knolls of mesic uplands
(G154XB131FL)

Custom Soil Resource Report

Other vegetative classification: Sandy soils on rises and knolls of mesic uplands (G154XB131FL), Upland Hardwood Hammock (R154XY008FL)
Hydric soil rating: No

Minor Components

Tavares

Percent of map unit: 5 percent
Landform: Flats on marine terraces, knolls on marine terraces, ridges on marine terraces
Landform position (two-dimensional): Backslope, shoulder
Landform position (three-dimensional): Base slope, interfluve
Down-slope shape: Convex
Across-slope shape: Linear
Other vegetative classification: Sandy soils on rises, knolls, and ridges of mesic uplands (G154XB121FL), Longleaf Pine-Turkey Oak Hills (R154XY002FL)
Hydric soil rating: No

Apopka

Percent of map unit: 5 percent
Landform: Knolls on marine terraces, ridges on marine terraces
Landform position (two-dimensional): Backslope
Landform position (three-dimensional): Side slope, interfluve, tread
Down-slope shape: Linear, convex
Across-slope shape: Convex, linear
Other vegetative classification: Sandy soils on ridges and dunes of xeric uplands (G154XB111FL), Longleaf Pine-Turkey Oak Hills (R154XY002FL), Upland Hardwood Hammock (R154XY008FL)
Hydric soil rating: No

Candler

Percent of map unit: 5 percent
Landform: Knolls on marine terraces, ridges on marine terraces
Landform position (two-dimensional): Backslope
Landform position (three-dimensional): Side slope, interfluve, tread
Down-slope shape: Convex
Across-slope shape: Convex
Other vegetative classification: Sandy soils on ridges and dunes of xeric uplands (G154XB111FL), Longleaf Pine-Turkey Oak Hills (R154XY002FL)
Hydric soil rating: No

15—Tavares fine sand, 0 to 5 percent slopes

Map Unit Setting

National map unit symbol: 2w0pz
Elevation: 30 to 160 feet
Mean annual precipitation: 44 to 56 inches
Mean annual air temperature: 68 to 75 degrees F
Frost-free period: 290 to 365 days
Farmland classification: Farmland of unique importance

Map Unit Composition

Tavares and similar soils: 85 percent

Minor components: 15 percent

Estimates are based on observations, descriptions, and transects of the mapunit.

Description of Tavares

Setting

Landform: Knolls on marine terraces, ridges on marine terraces

Landform position (two-dimensional): Backslope

Landform position (three-dimensional): Interfluve, side slope, tread, rise

Down-slope shape: Convex, linear

Across-slope shape: Linear

Parent material: Eolian or sandy marine deposits

Typical profile

A - 0 to 5 inches: fine sand

C - 5 to 80 inches: fine sand

Properties and qualities

Slope: 0 to 5 percent

Depth to restrictive feature: More than 80 inches

Drainage class: Moderately well drained

Runoff class: Negligible

Capacity of the most limiting layer to transmit water (Ksat): High to very high (5.95 to 19.98 in/hr)

Depth to water table: About 42 to 60 inches

Frequency of flooding: None

Frequency of ponding: None

Maximum salinity: Nonsaline to very slightly saline (0.0 to 2.0 mmhos/cm)

Sodium adsorption ratio, maximum: 4.0

Available water supply, 0 to 60 inches: Very low (about 2.6 inches)

Interpretive groups

Land capability classification (irrigated): None specified

Land capability classification (nonirrigated): 3s

Hydrologic Soil Group: A

Forage suitability group: Sandy soils on rises, knolls, and ridges of mesic uplands (G154XB121FL)

Other vegetative classification: Longleaf Pine-Turkey Oak Hills (R154XY002FL),
Sandy soils on rises, knolls, and ridges of mesic uplands (G154XB121FL)

Hydric soil rating: No

Minor Components

Candler

Percent of map unit: 5 percent

Landform: Knolls on marine terraces, ridges on marine terraces

Landform position (two-dimensional): Summit

Landform position (three-dimensional): Interfluve, tread

Down-slope shape: Linear, convex

Across-slope shape: Linear, convex, concave

Other vegetative classification: Sandy soils on ridges and dunes of xeric uplands (G154XB111FL), Longleaf Pine-Turkey Oak Hills (R154XY002FL)

Hydric soil rating: No

Custom Soil Resource Report

Apopka

Percent of map unit: 4 percent

Landform: Ridges on marine terraces, knolls on marine terraces

Landform position (two-dimensional): Summit, shoulder, footslope

Landform position (three-dimensional): Crest, side slope, nose slope

Down-slope shape: Convex

Across-slope shape: Linear

Other vegetative classification: Sandy soils on ridges and dunes of xeric uplands
(G154XB111FL), Longleaf Pine-Turkey Oak Hills (R154XY002FL)

Hydric soil rating: No

Zolfo

Percent of map unit: 3 percent

Landform: Knolls on marine terraces, rises on marine terraces

Landform position (three-dimensional): Interfluvium, rise

Down-slope shape: Convex, linear

Across-slope shape: Linear

Other vegetative classification: Sandy soils on rises and knolls of mesic uplands
(G155XB131FL), North Florida Flatwoods (R154XY004FL)

Hydric soil rating: No

Narcoossee

Percent of map unit: 3 percent

Landform: Knolls on marine terraces, rises on marine terraces

Landform position (three-dimensional): Interfluvium, rise

Down-slope shape: Linear, convex

Across-slope shape: Linear

Other vegetative classification: Sandy soils on rises and knolls of mesic uplands
(G155XB131FL), Upland Hardwood Hammock (R154XY008FL)

Hydric soil rating: No

16—Urban land, 0 to 2 percent slopes

Map Unit Setting

National map unit symbol: 2x9fc

Elevation: 0 to 200 feet

Mean annual precipitation: 40 to 68 inches

Mean annual air temperature: 68 to 79 degrees F

Frost-free period: 345 to 365 days

Farmland classification: Not prime farmland

Map Unit Composition

Urban land: 85 percent

Minor components: 15 percent

Estimates are based on observations, descriptions, and transects of the mapunit.

Description of Urban Land

Setting

Landform: Flatwoods on marine terraces, rises on marine terraces, knolls on marine terraces, ridges on marine terraces, hills on marine terraces
Landform position (two-dimensional): Summit, backslope
Landform position (three-dimensional): Interfluve, side slope, riser, talf, rise
Down-slope shape: Linear, convex
Across-slope shape: Linear
Parent material: No parent material

Interpretive groups

Land capability classification (irrigated): None specified
Forage suitability group: Forage suitability group not assigned (G155XB999FL)
Other vegetative classification: Forage suitability group not assigned (G155XB999FL)
Hydric soil rating: Unranked

Minor Components

Matlacha

Percent of map unit: 3 percent
Landform: Flats on marine terraces
Landform position (three-dimensional): Tread, talf
Down-slope shape: Convex, linear
Across-slope shape: Linear
Other vegetative classification: Forage suitability group not assigned (G155XB999FL)
Hydric soil rating: No

St. augustine

Percent of map unit: 3 percent
Landform: Marine terraces
Landform position (three-dimensional): Tread, rise
Down-slope shape: Linear
Across-slope shape: Convex
Other vegetative classification: Forage suitability group not assigned (G155XB999FL)
Hydric soil rating: No

Immokalee

Percent of map unit: 1 percent
Landform: Flatwoods on marine terraces
Landform position (three-dimensional): Riser, talf
Down-slope shape: Linear
Across-slope shape: Linear
Other vegetative classification: Sandy soils on flats of mesic or hydric lowlands (G155XB141FL), South Florida Flatwoods (R155XY003FL)
Hydric soil rating: No

Adamsville

Percent of map unit: 1 percent
Landform: Knolls on marine terraces, rises on marine terraces
Landform position (three-dimensional): Tread, rise
Down-slope shape: Convex
Across-slope shape: Linear

Custom Soil Resource Report

Other vegetative classification: Sandy soils on rises and knolls of mesic uplands (G155XB131FL), Upland Hardwood Hammock (R155XY008FL)
Hydric soil rating: No

Paola

Percent of map unit: 1 percent
Landform: Knolls on marine terraces, ridges on marine terraces
Landform position (two-dimensional): Backslope, summit
Landform position (three-dimensional): Side slope, interfluve, riser
Down-slope shape: Convex, linear
Across-slope shape: Linear
Other vegetative classification: Sandy soils on ridges and dunes of xeric uplands (G155XB111FL), Sand Pine Scrub (R155XY001FL)
Hydric soil rating: No

Myakka

Percent of map unit: 1 percent
Landform: Drainageways on flatwoods on marine terraces
Landform position (three-dimensional): Tread, talf, dip
Down-slope shape: Linear
Across-slope shape: Linear, concave
Other vegetative classification: Sandy soils on flats of mesic or hydric lowlands (G155XB141FL), South Florida Flatwoods (R155XY003FL)
Hydric soil rating: No

Pomello

Percent of map unit: 1 percent
Landform: Knolls on marine terraces, ridges on marine terraces
Landform position (two-dimensional): Backslope, summit
Landform position (three-dimensional): Side slope, interfluve, riser
Down-slope shape: Convex, linear
Across-slope shape: Linear
Other vegetative classification: Sandy soils on rises and knolls of mesic uplands (G155XB131FL), Sand Pine Scrub (R155XY001FL)
Hydric soil rating: No

Apopka

Percent of map unit: 1 percent
Landform: Ridges on marine terraces, hills on marine terraces
Landform position (two-dimensional): Summit, backslope
Landform position (three-dimensional): Interfluve, side slope, riser
Down-slope shape: Convex
Across-slope shape: Linear
Other vegetative classification: Sandy soils on ridges and dunes of xeric uplands (G155XB111FL), Longleaf Pine-Turkey Oak Hills (R155XY002FL)
Hydric soil rating: No

Cypress lake

Percent of map unit: 1 percent
Landform: Drainageways on marine terraces, flats on marine terraces
Landform position (three-dimensional): Tread, dip, talf
Down-slope shape: Linear, convex
Across-slope shape: Concave, linear
Other vegetative classification: Sandy over loamy soils on flats of hydric or mesic lowlands (G155XB241FL), South Florida Flatwoods (R155XY003FL)
Hydric soil rating: Yes

Eaugallie

Percent of map unit: 1 percent
Landform: Flatwoods on marine terraces
Landform position (three-dimensional): Tread, talf
Down-slope shape: Convex
Across-slope shape: Linear
Other vegetative classification: South Florida Flatwoods (R155XY003FL), Sandy soils on flats of mesic or hydric lowlands (G155XB141FL)
Hydric soil rating: No

Brynwood

Percent of map unit: 1 percent
Landform: Flatwoods on marine terraces
Landform position (three-dimensional): Tread, talf
Down-slope shape: Linear
Across-slope shape: Linear
Other vegetative classification: Sandy soils on flats of mesic or hydric lowlands (G155XB141FL), South Florida Flatwoods (R155XY003FL)
Hydric soil rating: Yes

17—Smyrna and Myakka fine sands

Map Unit Setting

National map unit symbol: 1jtv1
Elevation: 20 to 260 feet
Mean annual precipitation: 46 to 54 inches
Mean annual air temperature: 70 to 77 degrees F
Frost-free period: 350 to 365 days
Farmland classification: Not prime farmland

Map Unit Composition

Smyrna, non-hydric, and similar soils: 41 percent
Myakka and similar soils: 39 percent
Smyrna, hydric, and similar soils: 15 percent
Minor components: 5 percent
Estimates are based on observations, descriptions, and transects of the mapunit.

Description of Smyrna, Non-hydric

Setting

Landform: Flats on marine terraces
Landform position (three-dimensional): Talf
Down-slope shape: Convex
Across-slope shape: Linear
Parent material: Sandy marine deposits

Typical profile

A - 0 to 4 inches: fine sand
E - 4 to 12 inches: fine sand
Bh - 12 to 25 inches: fine sand

Custom Soil Resource Report

E' - 25 to 42 inches: fine sand
B'h - 42 to 48 inches: fine sand
C - 48 to 80 inches: fine sand

Properties and qualities

Slope: 0 to 2 percent
Depth to restrictive feature: More than 80 inches
Drainage class: Poorly drained
Runoff class: High
Capacity of the most limiting layer to transmit water (Ksat): Moderately high to high (0.57 to 5.95 in/hr)
Depth to water table: About 6 to 18 inches
Frequency of flooding: None
Frequency of ponding: None
Maximum salinity: Nonsaline to very slightly saline (0.0 to 2.0 mmhos/cm)
Sodium adsorption ratio, maximum: 4.0
Available water supply, 0 to 60 inches: Low (about 4.9 inches)

Interpretive groups

Land capability classification (irrigated): None specified
Land capability classification (nonirrigated): 4w
Hydrologic Soil Group: A/D
Ecological site: F155XY120FL - Sandy Flatwoods and Hammocks
Forage suitability group: Sandy soils on flats of mesic or hydric lowlands (G154XB141FL)
Other vegetative classification: Sandy soils on flats of mesic or hydric lowlands (G154XB141FL), South Florida Flatwoods (R154XY003FL)
Hydric soil rating: No

Description of Myakka

Setting

Landform: Flatwoods on marine terraces
Landform position (three-dimensional): Talf
Down-slope shape: Convex
Across-slope shape: Linear
Parent material: Sandy marine deposits

Typical profile

A - 0 to 7 inches: fine sand
E - 7 to 25 inches: fine sand
Bh - 25 to 36 inches: fine sand
C - 36 to 80 inches: fine sand

Properties and qualities

Slope: 0 to 2 percent
Depth to restrictive feature: More than 80 inches
Drainage class: Poorly drained
Runoff class: High
Capacity of the most limiting layer to transmit water (Ksat): Moderately high to high (0.57 to 5.95 in/hr)
Depth to water table: About 6 to 18 inches
Frequency of flooding: None
Frequency of ponding: None
Maximum salinity: Nonsaline to very slightly saline (0.0 to 2.0 mmhos/cm)
Sodium adsorption ratio, maximum: 4.0
Available water supply, 0 to 60 inches: Low (about 5.6 inches)

Interpretive groups

Land capability classification (irrigated): None specified
Land capability classification (nonirrigated): 4w
Hydrologic Soil Group: A/D
Ecological site: F155XY120FL - Sandy Flatwoods and Hammocks
Forage suitability group: Sandy soils on flats of mesic or hydric lowlands (G154XB141FL)
Other vegetative classification: Sandy soils on flats of mesic or hydric lowlands (G154XB141FL), South Florida Flatwoods (R154XY003FL)
Hydric soil rating: No

Description of Smyrna, Hydric

Setting

Landform: Flats on marine terraces
Landform position (three-dimensional): Talf
Down-slope shape: Linear
Across-slope shape: Linear
Parent material: Sandy marine deposits

Typical profile

A - 0 to 4 inches: fine sand
E - 4 to 12 inches: fine sand
Bh - 12 to 25 inches: fine sand
E' - 25 to 42 inches: fine sand
B'h - 42 to 48 inches: fine sand
C - 48 to 80 inches: fine sand

Properties and qualities

Slope: 0 to 2 percent
Depth to restrictive feature: More than 80 inches
Drainage class: Poorly drained
Runoff class: High
Capacity of the most limiting layer to transmit water (Ksat): Moderately high to high (0.57 to 5.95 in/hr)
Depth to water table: About 0 to 12 inches
Frequency of flooding: None
Frequency of ponding: None
Maximum salinity: Nonsaline to very slightly saline (0.0 to 2.0 mmhos/cm)
Sodium adsorption ratio, maximum: 4.0
Available water supply, 0 to 60 inches: Low (about 4.9 inches)

Interpretive groups

Land capability classification (irrigated): None specified
Land capability classification (nonirrigated): 4w
Hydrologic Soil Group: A/D
Ecological site: F155XY120FL - Sandy Flatwoods and Hammocks
Forage suitability group: Sandy soils on flats of mesic or hydric lowlands (G154XB141FL)
Other vegetative classification: Sandy soils on flats of mesic or hydric lowlands (G154XB141FL), South Florida Flatwoods (R154XY003FL)
Hydric soil rating: Yes

Minor Components

Basinger

Percent of map unit: 2 percent

Landform: Drainageways on marine terraces

Landform position (three-dimensional): Dip

Down-slope shape: Linear

Across-slope shape: Concave

Ecological site: R155XY070FL - Sandy Freshwater Isolated Marshes and Swamps

Other vegetative classification: Sandy soils on flats of mesic or hydric lowlands
(G154XB141FL), Slough (R154XY011FL)

Hydric soil rating: Yes

Pomona, non-hydric

Percent of map unit: 1 percent

Landform: Flatwoods on marine terraces

Landform position (three-dimensional): Talf

Down-slope shape: Convex

Across-slope shape: Linear

Ecological site: F155XY120FL - Sandy Flatwoods and Hammocks

Other vegetative classification: Sandy soils on flats of mesic or hydric lowlands
(G154XB141FL), South Florida Flatwoods (R154XY003FL)

Hydric soil rating: No

Ona, non-hydric

Percent of map unit: 1 percent

Landform: Flats on marine terraces

Landform position (three-dimensional): Talf

Down-slope shape: Convex

Across-slope shape: Linear

Ecological site: F155XY120FL - Sandy Flatwoods and Hammocks

Other vegetative classification: Sandy soils on flats of mesic or hydric lowlands
(G154XB141FL), South Florida Flatwoods (R154XY003FL)

Hydric soil rating: No

Immokalee, non-hydric

Percent of map unit: 1 percent

Landform: Flatwoods on marine terraces

Landform position (three-dimensional): Talf

Down-slope shape: Convex

Across-slope shape: Linear

Ecological site: F155XY120FL - Sandy Flatwoods and Hammocks

Other vegetative classification: Sandy soils on flats of mesic or hydric lowlands
(G154XB141FL), South Florida Flatwoods (R154XY003FL)

Hydric soil rating: No

21—Immokalee sand

Map Unit Setting

National map unit symbol: 1jtv4
Elevation: 50 to 260 feet
Mean annual precipitation: 46 to 54 inches
Mean annual air temperature: 70 to 77 degrees F
Frost-free period: 350 to 365 days
Farmland classification: Not prime farmland

Map Unit Composition

Immokalee, non-hydric, and similar soils: 75 percent
Immokalee, hydric, and similar soils: 10 percent
Minor components: 15 percent
Estimates are based on observations, descriptions, and transects of the mapunit.

Description of Immokalee, Non-hydric

Setting

Landform: Flatwoods on marine terraces
Landform position (three-dimensional): Talf
Down-slope shape: Convex
Across-slope shape: Linear
Parent material: Sandy marine deposits

Typical profile

A - 0 to 7 inches: sand
E - 7 to 39 inches: sand
Bh - 39 to 58 inches: sand
E' - 58 to 66 inches: sand
B'h - 66 to 80 inches: sand

Properties and qualities

Slope: 0 to 2 percent
Depth to restrictive feature: More than 80 inches
Drainage class: Poorly drained
Runoff class: High
Capacity of the most limiting layer to transmit water (Ksat): Moderately high to high
(0.57 to 1.98 in/hr)
Depth to water table: About 6 to 18 inches
Frequency of flooding: None
Frequency of ponding: None
Maximum salinity: Nonsaline to very slightly saline (0.0 to 2.0 mmhos/cm)
Sodium adsorption ratio, maximum: 4.0
Available water supply, 0 to 60 inches: Low (about 5.3 inches)

Custom Soil Resource Report

Interpretive groups

Land capability classification (irrigated): None specified
Land capability classification (nonirrigated): 4w
Hydrologic Soil Group: B/D
Ecological site: F155XY120FL - Sandy Flatwoods and Hammocks
Forage suitability group: Sandy soils on flats of mesic or hydric lowlands (G154XB141FL)
Other vegetative classification: Sandy soils on flats of mesic or hydric lowlands (G154XB141FL), South Florida Flatwoods (R154XY003FL)
Hydric soil rating: No

Description of Immokalee, Hydric

Setting

Landform: Flats on marine terraces
Landform position (three-dimensional): Talf
Down-slope shape: Concave
Across-slope shape: Linear
Parent material: Sandy marine deposits

Typical profile

A - 0 to 7 inches: sand
E - 7 to 39 inches: sand
Bh - 39 to 58 inches: sand
E' - 58 to 66 inches: sand
B'h - 66 to 80 inches: sand

Properties and qualities

Slope: 0 to 2 percent
Depth to restrictive feature: More than 80 inches
Drainage class: Poorly drained
Runoff class: High
Capacity of the most limiting layer to transmit water (Ksat): Moderately high to high (0.57 to 1.98 in/hr)
Depth to water table: About 0 to 12 inches
Frequency of flooding: None
Frequency of ponding: None
Maximum salinity: Nonsaline to very slightly saline (0.0 to 2.0 mmhos/cm)
Sodium adsorption ratio, maximum: 4.0
Available water supply, 0 to 60 inches: Low (about 5.3 inches)

Interpretive groups

Land capability classification (irrigated): None specified
Land capability classification (nonirrigated): 4w
Hydrologic Soil Group: B/D
Ecological site: F155XY120FL - Sandy Flatwoods and Hammocks
Forage suitability group: Sandy soils on flats of mesic or hydric lowlands (G154XB141FL)
Other vegetative classification: Sandy soils on flats of mesic or hydric lowlands (G154XB141FL), South Florida Flatwoods (R154XY003FL)
Hydric soil rating: Yes

Minor Components

Basinger

Percent of map unit: 5 percent

Custom Soil Resource Report

Landform: Drainageways on marine terraces
Landform position (three-dimensional): Dip
Down-slope shape: Linear
Across-slope shape: Concave
Ecological site: R155XY070FL - Sandy Freshwater Isolated Marshes and Swamps
Other vegetative classification: Sandy soils on flats of mesic or hydric lowlands (G154XB141FL), Slough (R154XY011FL)
Hydric soil rating: Yes

Smyrna, non-hydric

Percent of map unit: 5 percent
Landform: Flats on marine terraces
Landform position (three-dimensional): Talf
Down-slope shape: Convex
Across-slope shape: Linear
Ecological site: F155XY120FL - Sandy Flatwoods and Hammocks
Other vegetative classification: Sandy soils on flats of mesic or hydric lowlands (G154XB141FL), South Florida Flatwoods (R154XY003FL)
Hydric soil rating: No

Myakka

Percent of map unit: 5 percent
Landform: Flatwoods on marine terraces
Landform position (three-dimensional): Talf
Down-slope shape: Convex
Across-slope shape: Linear
Ecological site: F155XY120FL - Sandy Flatwoods and Hammocks
Other vegetative classification: Sandy soils on flats of mesic or hydric lowlands (G154XB141FL), South Florida Flatwoods (R154XY003FL)
Hydric soil rating: No

23—Ona-Ona, wet, fine sand, 0 to 2 percent slopes

Map Unit Setting

National map unit symbol: 2w4gx
Elevation: 10 to 130 feet
Mean annual precipitation: 46 to 56 inches
Mean annual air temperature: 66 to 77 degrees F
Frost-free period: 325 to 365 days
Farmland classification: Not prime farmland

Map Unit Composition

Ona and similar soils: 75 percent
Ona, wet, and similar soils: 12 percent
Minor components: 13 percent
Estimates are based on observations, descriptions, and transects of the mapunit.

Description of Ona

Setting

Landform: Flatwoods on marine terraces
Landform position (three-dimensional): Talf
Down-slope shape: Linear
Across-slope shape: Linear
Parent material: Sandy marine deposits

Typical profile

A - 0 to 9 inches: fine sand
Bh - 9 to 16 inches: fine sand
C - 16 to 80 inches: fine sand

Properties and qualities

Slope: 0 to 2 percent
Depth to restrictive feature: More than 80 inches
Drainage class: Poorly drained
Runoff class: High
Capacity of the most limiting layer to transmit water (Ksat): Moderately high to high (0.57 to 1.98 in/hr)
Depth to water table: About 6 to 18 inches
Frequency of flooding: None
Frequency of ponding: None
Maximum salinity: Nonsaline to very slightly saline (0.0 to 2.0 mmhos/cm)
Sodium adsorption ratio, maximum: 4.0
Available water supply, 0 to 60 inches: Low (about 4.6 inches)

Interpretive groups

Land capability classification (irrigated): None specified
Land capability classification (nonirrigated): 3w
Hydrologic Soil Group: B/D
Ecological site: F155XY120FL - Sandy Flatwoods and Hammocks
Forage suitability group: Sandy soils on flats of mesic or hydric lowlands (G155XB141FL)
Other vegetative classification: Sandy soils on flats of mesic or hydric lowlands (G155XB141FL)
Hydric soil rating: No

Description of Ona, Wet

Setting

Landform: Sloughs on marine terraces
Landform position (three-dimensional): Talf
Down-slope shape: Linear
Across-slope shape: Linear
Parent material: Sandy marine deposits

Typical profile

A - 0 to 9 inches: fine sand
Bh - 9 to 16 inches: fine sand
C - 16 to 80 inches: fine sand

Properties and qualities

Slope: 0 to 2 percent
Depth to restrictive feature: More than 80 inches
Drainage class: Poorly drained

Custom Soil Resource Report

Runoff class: High

Capacity of the most limiting layer to transmit water (Ksat): Moderately high to high
(0.57 to 1.98 in/hr)

Depth to water table: About 0 to 18 inches

Frequency of flooding: None

Frequency of ponding: None

Maximum salinity: Nonsaline to very slightly saline (0.0 to 2.0 mmhos/cm)

Sodium adsorption ratio, maximum: 4.0

Available water supply, 0 to 60 inches: Low (about 4.6 inches)

Interpretive groups

Land capability classification (irrigated): None specified

Land capability classification (nonirrigated): 3w

Hydrologic Soil Group: B/D

Ecological site: R155XY070FL - Sandy Freshwater Isolated Marshes and Swamps

Forage suitability group: Sandy soils on flats of mesic or hydric lowlands
(G155XB141FL)

Other vegetative classification: Sandy soils on flats of mesic or hydric lowlands
(G155XB141FL)

Hydric soil rating: Yes

Minor Components

Myakka

Percent of map unit: 5 percent

Landform: Flatwoods on marine terraces

Landform position (three-dimensional): Tread, talf

Down-slope shape: Linear

Across-slope shape: Linear

Ecological site: F155XY120FL - Sandy Flatwoods and Hammocks

Other vegetative classification: Sandy soils on flats of mesic or hydric lowlands
(G155XB141FL), South Florida Flatwoods (R155XY003FL)

Hydric soil rating: No

Basinger, hydric

Percent of map unit: 4 percent

Landform: Drainageways on marine terraces

Landform position (three-dimensional): Tread, dip

Down-slope shape: Concave, linear

Across-slope shape: Concave, linear

Ecological site: R155XY070FL - Sandy Freshwater Isolated Marshes and Swamps

Other vegetative classification: Sandy soils on flats of mesic or hydric lowlands
(G155XB141FL), Slough (R155XY011FL)

Hydric soil rating: Yes

Immokalee

Percent of map unit: 4 percent

Landform: Flatwoods on marine terraces

Landform position (three-dimensional): Tread, talf

Down-slope shape: Linear

Across-slope shape: Linear

Ecological site: F155XY120FL - Sandy Flatwoods and Hammocks

Other vegetative classification: Sandy soils on flats of mesic or hydric lowlands
(G155XB141FL), South Florida Flatwoods (R155XY003FL)

Hydric soil rating: No

25—Placid and Myakka fine sands, depressional

Map Unit Setting

National map unit symbol: 1jtv8

Elevation: 20 to 250 feet

Mean annual precipitation: 46 to 54 inches

Mean annual air temperature: 70 to 77 degrees F

Frost-free period: 350 to 365 days

Farmland classification: Not prime farmland

Map Unit Composition

Placid, depressional, and similar soils: 60 percent

Myakka, depressional, and similar soils: 30 percent

Minor components: 10 percent

Estimates are based on observations, descriptions, and transects of the mapunit.

Description of Placid, Depressional

Setting

Landform: Depressions on marine terraces

Landform position (three-dimensional): Dip

Down-slope shape: Concave

Across-slope shape: Concave

Parent material: Sandy marine deposits

Typical profile

A - 0 to 18 inches: fine sand

Cg - 18 to 80 inches: fine sand

Properties and qualities

Slope: 0 to 2 percent

Depth to restrictive feature: More than 80 inches

Drainage class: Very poorly drained

Runoff class: High

Capacity of the most limiting layer to transmit water (Ksat): High to very high (5.95 to 19.98 in/hr)

Depth to water table: About 0 inches

Frequency of flooding: None

Frequency of ponding: Frequent

Maximum salinity: Nonsaline to very slightly saline (0.0 to 2.0 mmhos/cm)

Sodium adsorption ratio, maximum: 4.0

Available water supply, 0 to 60 inches: Moderate (about 6.2 inches)

Interpretive groups

Land capability classification (irrigated): None specified

Land capability classification (nonirrigated): 7w

Hydrologic Soil Group: A/D

Ecological site: R155XY070FL - Sandy Freshwater Isolated Marshes and Swamps

Custom Soil Resource Report

Forage suitability group: Sandy soils on stream terraces, flood plains, or in depressions (G154XB145FL)

Other vegetative classification: Sandy soils on stream terraces, flood plains, or in depressions (G154XB145FL), Freshwater Marshes and Ponds (R154XY010FL)

Hydric soil rating: Yes

Description of Myakka, Depressional

Setting

Landform: Depressions on marine terraces

Landform position (three-dimensional): Dip

Down-slope shape: Concave

Across-slope shape: Concave

Parent material: Sandy marine deposits

Typical profile

A - 0 to 3 inches: fine sand

E - 3 to 25 inches: fine sand

Bh - 25 to 35 inches: fine sand

Cg - 35 to 80 inches: fine sand

Properties and qualities

Slope: 0 to 2 percent

Depth to restrictive feature: More than 80 inches

Drainage class: Very poorly drained

Runoff class: High

Capacity of the most limiting layer to transmit water (Ksat): Moderately high to high (0.57 to 5.95 in/hr)

Depth to water table: About 0 inches

Frequency of flooding: None

Frequency of ponding: Frequent

Maximum salinity: Nonsaline to very slightly saline (0.0 to 2.0 mmhos/cm)

Sodium adsorption ratio, maximum: 4.0

Available water supply, 0 to 60 inches: Low (about 5.5 inches)

Interpretive groups

Land capability classification (irrigated): None specified

Land capability classification (nonirrigated): 7w

Hydrologic Soil Group: A/D

Ecological site: R155XY070FL - Sandy Freshwater Isolated Marshes and Swamps

Forage suitability group: Sandy soils on stream terraces, flood plains, or in depressions (G154XB145FL)

Other vegetative classification: Sandy soils on stream terraces, flood plains, or in depressions (G154XB145FL), Freshwater Marshes and Ponds (R154XY010FL)

Hydric soil rating: Yes

Minor Components

Basinger, depressional

Percent of map unit: 3 percent

Landform: Depressions on marine terraces

Landform position (three-dimensional): Dip

Down-slope shape: Concave

Across-slope shape: Concave

Custom Soil Resource Report

Ecological site: R155XY070FL - Sandy Freshwater Isolated Marshes and Swamps

Other vegetative classification: Sandy soils on stream terraces, flood plains, or in depressions (G154XB145FL), Freshwater Marshes and Ponds (R154XY010FL)

Hydric soil rating: Yes

Ona, hydric

Percent of map unit: 3 percent

Landform: Flats on marine terraces

Landform position (three-dimensional): Talf

Down-slope shape: Linear

Across-slope shape: Linear

Ecological site: R155XY070FL - Sandy Freshwater Isolated Marshes and Swamps

Other vegetative classification: Sandy soils on flats of mesic or hydric lowlands (G154XB141FL), South Florida Flatwoods (R154XY003FL)

Hydric soil rating: Yes

St. Johns, hydric

Percent of map unit: 2 percent

Landform: Flats on marine terraces

Landform position (three-dimensional): Talf

Down-slope shape: Linear

Across-slope shape: Linear

Ecological site: R155XY070FL - Sandy Freshwater Isolated Marshes and Swamps

Other vegetative classification: Sandy soils on flats of mesic or hydric lowlands (G154XB141FL), Cutthroat Seeps (R154XY007FL)

Hydric soil rating: Yes

Pomona, hydric

Percent of map unit: 2 percent

Landform: Flats on marine terraces

Landform position (three-dimensional): Talf

Down-slope shape: Linear

Across-slope shape: Linear

Ecological site: R155XY070FL - Sandy Freshwater Isolated Marshes and Swamps

Other vegetative classification: Sandy soils on flats of mesic or hydric lowlands (G154XB141FL), South Florida Flatwoods (R154XY003FL)

Hydric soil rating: Yes

26—Lochloosa fine sand

Map Unit Setting

National map unit symbol: 1jtv9

Elevation: 10 to 160 feet

Mean annual precipitation: 46 to 54 inches

Mean annual air temperature: 70 to 77 degrees F

Frost-free period: 350 to 365 days

Farmland classification: Farmland of unique importance

Map Unit Composition

Lochloosa and similar soils: 90 percent

Minor components: 10 percent

Estimates are based on observations, descriptions, and transects of the mapunit.

Description of Lochloosa

Setting

Landform: Rises on marine terraces, flats on marine terraces

Landform position (three-dimensional): Interfluve

Down-slope shape: Convex

Across-slope shape: Linear

Parent material: Sandy and loamy marine deposits

Typical profile

A - 0 to 6 inches: fine sand

E - 6 to 36 inches: fine sand

Btg - 36 to 65 inches: sandy clay loam

BCg - 65 to 80 inches: sandy clay loam

Properties and qualities

Slope: 0 to 2 percent

Depth to restrictive feature: More than 80 inches

Drainage class: Somewhat poorly drained

Runoff class: Low

Capacity of the most limiting layer to transmit water (Ksat): Moderately low to moderately high (0.06 to 0.20 in/hr)

Depth to water table: About 30 to 60 inches

Frequency of flooding: None

Frequency of ponding: None

Maximum salinity: Nonsaline to very slightly saline (0.0 to 2.0 mmhos/cm)

Sodium adsorption ratio, maximum: 4.0

Available water supply, 0 to 60 inches: Moderate (about 7.8 inches)

Interpretive groups

Land capability classification (irrigated): None specified

Land capability classification (nonirrigated): 2w

Hydrologic Soil Group: C

Forage suitability group: Sandy over loamy soils on rises and knolls of mesic uplands (G154XB231FL)

Other vegetative classification: Sandy over loamy soils on rises and knolls of mesic uplands (G154XB231FL), Upland Hardwood Hammock (R154XY008FL)

Hydric soil rating: No

Minor Components

Kendrick

Percent of map unit: 3 percent

Landform: Knolls on marine terraces, ridges on marine terraces

Landform position (three-dimensional): Interfluve, side slope

Down-slope shape: Convex

Across-slope shape: Linear

Other vegetative classification: Sandy over loamy soils on knolls and ridges of mesic uplands (G154XB211FL), Upland Hardwood Hammock (R154XY008FL)

Hydric soil rating: No

Custom Soil Resource Report

Adamsville

Percent of map unit: 3 percent

Landform: Ridges on marine terraces, rises on marine terraces

Landform position (three-dimensional): Interfluve, tal

Down-slope shape: Convex

Across-slope shape: Linear

Other vegetative classification: Sandy soils on rises and knolls of mesic uplands (G154XB131FL), South Florida Flatwoods (R154XY003FL)

Hydric soil rating: No

Millhopper

Percent of map unit: 2 percent

Landform: Knolls on marine terraces, ridges on marine terraces

Landform position (three-dimensional): Interfluve

Down-slope shape: Convex

Across-slope shape: Linear

Other vegetative classification: Sandy soils on rises, knolls, and ridges of mesic uplands (G154XB121FL), Upland Hardwood Hammock (R154XY008FL)

Hydric soil rating: No

Sparr

Percent of map unit: 2 percent

Landform: Knolls on marine terraces, rises on marine terraces

Landform position (three-dimensional): Interfluve, rise

Down-slope shape: Convex

Across-slope shape: Linear

Other vegetative classification: Sandy soils on rises and knolls of mesic uplands (G154XB131FL), Upland Hardwood Hammock (R154XY008FL)

Hydric soil rating: No

27—Kendrick fine sand, 0 to 5 percent slopes

Map Unit Setting

National map unit symbol: 2v171

Elevation: 30 to 300 feet

Mean annual precipitation: 44 to 56 inches

Mean annual air temperature: 68 to 75 degrees F

Frost-free period: 300 to 365 days

Farmland classification: Farmland of unique importance

Map Unit Composition

Kendrick and similar soils: 80 percent

Minor components: 20 percent

Estimates are based on observations, descriptions, and transects of the mapunit.

Description of Kendrick

Setting

Landform: Knolls on marine terraces, ridges on marine terraces

Landform position (two-dimensional): Shoulder, summit

Custom Soil Resource Report

Landform position (three-dimensional): Interfluve
Down-slope shape: Convex
Across-slope shape: Linear
Parent material: Sandy marine deposits over loamy marine deposits

Typical profile

A - 0 to 7 inches: fine sand
E - 7 to 28 inches: fine sand
Bt - 28 to 73 inches: sandy clay loam
BC - 73 to 80 inches: sandy clay loam

Properties and qualities

Slope: 0 to 5 percent
Depth to restrictive feature: More than 80 inches
Drainage class: Well drained
Runoff class: Negligible
Capacity of the most limiting layer to transmit water (Ksat): Moderately high to high
(0.60 to 2.00 in/hr)
Depth to water table: More than 80 inches
Frequency of flooding: None
Frequency of ponding: None
Maximum salinity: Nonsaline to very slightly saline (0.0 to 2.0 mmhos/cm)
Sodium adsorption ratio, maximum: 4.0
Available water supply, 0 to 60 inches: Low (about 4.8 inches)

Interpretive groups

Land capability classification (irrigated): None specified
Land capability classification (nonirrigated): 2e
Hydrologic Soil Group: A
Forage suitability group: Sandy over loamy soils on knolls and ridges of mesic uplands (G154XB211FL)
Other vegetative classification: Sandy over loamy soils on knolls and ridges of mesic uplands (G154XB211FL), Upland Hardwood Hammock (R154XY008FL)
Hydric soil rating: No

Minor Components

Candler

Percent of map unit: 7 percent
Landform: Ridges on marine terraces, knolls on marine terraces
Landform position (two-dimensional): Backslope
Landform position (three-dimensional): Interfluve, side slope
Down-slope shape: Convex
Across-slope shape: Convex
Other vegetative classification: Longleaf Pine-Turkey Oak Hills (R154XY002FL), Sandy soils on ridges and dunes of xeric uplands (G155XB111FL)
Hydric soil rating: No

Micanopy

Percent of map unit: 5 percent
Landform: Rises on marine terraces
Landform position (two-dimensional): Backslope
Landform position (three-dimensional): Interfluve, talf
Down-slope shape: Convex
Across-slope shape: Linear
Other vegetative classification: Loamy and clayey soils on flats and rises of mesic lowlands (G154XB331FL)

Custom Soil Resource Report

Hydric soil rating: No

Nobleton

Percent of map unit: 4 percent

Landform: Rises on marine terraces

Landform position (two-dimensional): Backslope

Landform position (three-dimensional): Interfluve

Down-slope shape: Convex

Across-slope shape: Linear

Other vegetative classification: Sandy over loamy soils on rises and knolls of mesic uplands (G154XB231FL)

Hydric soil rating: No

Blichton

Percent of map unit: 4 percent

Landform: Ridges on marine terraces, knolls on marine terraces

Landform position (two-dimensional): Backslope

Landform position (three-dimensional): Side slope, interfluve

Down-slope shape: Convex

Across-slope shape: Linear

Other vegetative classification: Sandy over loamy, loamy, or clayey soils on flats and rises of hydric uplands (G154XB441FL)

Hydric soil rating: No

29—St. Lucie fine sand, 0 to 5 percent slopes

Map Unit Setting

National map unit symbol: 2v17s

Elevation: 80 to 160 feet

Mean annual precipitation: 44 to 56 inches

Mean annual air temperature: 68 to 75 degrees F

Frost-free period: 300 to 365 days

Farmland classification: Not prime farmland

Map Unit Composition

St. lucie and similar soils: 90 percent

Minor components: 10 percent

Estimates are based on observations, descriptions, and transects of the mapunit.

Description of St. Lucie

Setting

Landform: Knolls on marine terraces, ridges on marine terraces

Landform position (two-dimensional): Backslope

Landform position (three-dimensional): Interfluve

Down-slope shape: Convex

Across-slope shape: Linear

Parent material: Eolian or sandy marine deposits

Typical profile

A - 0 to 4 inches: fine sand

Custom Soil Resource Report

C - 4 to 80 inches: fine sand

Properties and qualities

Slope: 0 to 5 percent

Depth to restrictive feature: More than 80 inches

Drainage class: Excessively drained

Runoff class: Negligible

Capacity of the most limiting layer to transmit water (Ksat): Very high (19.98 to 50.02 in/hr)

Depth to water table: More than 80 inches

Frequency of flooding: None

Frequency of ponding: None

Maximum salinity: Nonsaline to very slightly saline (0.0 to 2.0 mmhos/cm)

Sodium adsorption ratio, maximum: 4.0

Available water supply, 0 to 60 inches: Very low (about 2.4 inches)

Interpretive groups

Land capability classification (irrigated): None specified

Land capability classification (nonirrigated): 7s

Hydrologic Soil Group: A

Forage suitability group: Sandy soils on ridges and dunes of xeric uplands (G154XB111FL)

Other vegetative classification: Sandy soils on ridges and dunes of xeric uplands (G154XB111FL), Sand Pine Scrub (R154XY001FL)

Hydric soil rating: No

Minor Components

Archbold

Percent of map unit: 4 percent

Landform: Knolls on marine terraces, ridges on marine terraces

Landform position (two-dimensional): Backslope

Landform position (three-dimensional): Interfluvium

Down-slope shape: Convex

Across-slope shape: Linear

Other vegetative classification: Sandy soils on rises, knolls, and ridges of mesic uplands (G154XB121FL), Sand Pine Scrub (R154XY001FL)

Hydric soil rating: No

Myakka

Percent of map unit: 3 percent

Landform: Flats on marine terraces

Landform position (two-dimensional): Shoulder

Landform position (three-dimensional): Interfluvium, tread, talf

Down-slope shape: Convex

Across-slope shape: Linear

Other vegetative classification: South Florida Flatwoods (R154XY003FL), Sandy soils on flats of mesic or hydric lowlands (G154XB141FL)

Hydric soil rating: No

Cassia

Percent of map unit: 3 percent

Landform: Rises on marine terraces

Landform position (two-dimensional): Backslope

Landform position (three-dimensional): Interfluvium, rise

Down-slope shape: Convex

Across-slope shape: Linear

Custom Soil Resource Report

Other vegetative classification: Sandy soils on rises and knolls of mesic uplands
(G154XB131FL)
Hydric soil rating: No

31—Adamsville fine sand, 0 to 2 percent slopes

Map Unit Setting

National map unit symbol: 2r8h8
Elevation: 10 to 100 feet
Mean annual precipitation: 47 to 56 inches
Mean annual air temperature: 68 to 75 degrees F
Frost-free period: 290 to 365 days
Farmland classification: Farmland of unique importance

Map Unit Composition

Adamsville and similar soils: 95 percent
Minor components: 5 percent
Estimates are based on observations, descriptions, and transects of the mapunit.

Description of Adamsville

Setting

Landform: Flats on marine terraces, rises on marine terraces
Landform position (two-dimensional): Summit
Landform position (three-dimensional): Interfluve, talf
Down-slope shape: Convex
Across-slope shape: Linear
Parent material: Sandy marine deposits

Typical profile

Ap - 0 to 7 inches: fine sand
C1 - 7 to 20 inches: fine sand
C2 - 20 to 80 inches: fine sand

Properties and qualities

Slope: 0 to 2 percent
Depth to restrictive feature: More than 80 inches
Drainage class: Somewhat poorly drained
Runoff class: Very low
Capacity of the most limiting layer to transmit water (Ksat): High to very high (5.95 to 19.98 in/hr)
Depth to water table: About 18 to 42 inches
Frequency of flooding: None
Frequency of ponding: None
Maximum salinity: Nonsaline to very slightly saline (0.0 to 2.0 mmhos/cm)
Sodium adsorption ratio, maximum: 4.0
Available water supply, 0 to 60 inches: Very low (about 3.0 inches)

Interpretive groups

Land capability classification (irrigated): None specified
Land capability classification (nonirrigated): 3w

Custom Soil Resource Report

Hydrologic Soil Group: A/D

Forage suitability group: Sandy soils on rises and knolls of mesic uplands (G154XB131FL), Sandy soils on rises and knolls of mesic uplands (G155XB131FL)

Other vegetative classification: Sandy soils on rises and knolls of mesic uplands (G154XB131FL), South Florida Flatwoods (R154XY003FL), Upland Hardwood Hammock (R155XY008FL), Sandy soils on rises and knolls of mesic uplands (G155XB131FL)

Hydric soil rating: No

Minor Components

Myakka

Percent of map unit: 3 percent

Landform: Flatwoods on marine terraces

Landform position (three-dimensional): Tread, talf

Down-slope shape: Convex

Across-slope shape: Linear

Other vegetative classification: Sandy soils on flats of mesic or hydric lowlands (G155XB141FL), South Florida Flatwoods (R155XY003FL)

Hydric soil rating: No

Basinger

Percent of map unit: 2 percent

Landform: Drainageways

Landform position (three-dimensional): Dip, talf

Down-slope shape: Concave, linear

Across-slope shape: Concave, convex

Other vegetative classification: Sandy soils on flats of mesic or hydric lowlands (G155XB141FL), Slough (R155XY011FL)

Hydric soil rating: Yes

33—Holopaw fine sand, frequently ponded, 0 to 1 percent slopes

Map Unit Setting

National map unit symbol: 2x9g8

Elevation: 0 to 190 feet

Mean annual precipitation: 46 to 63 inches

Mean annual air temperature: 68 to 77 degrees F

Frost-free period: 350 to 365 days

Farmland classification: Not prime farmland

Map Unit Composition

Holopaw and similar soils: 85 percent

Minor components: 15 percent

Estimates are based on observations, descriptions, and transects of the mapunit.

Description of Holopaw

Setting

Landform: Depressions on marine terraces
Landform position (three-dimensional): Tread, dip
Down-slope shape: Concave
Across-slope shape: Linear, concave
Parent material: Sandy and loamy marine deposits

Typical profile

A - 0 to 4 inches: fine sand
Eg - 4 to 50 inches: fine sand
Btg - 50 to 66 inches: fine sandy loam
Cg - 66 to 80 inches: loamy fine sand

Properties and qualities

Slope: 0 to 1 percent
Depth to restrictive feature: More than 80 inches
Drainage class: Very poorly drained
Runoff class: Negligible
Capacity of the most limiting layer to transmit water (Ksat): High (2.00 to 6.00 in/hr)
Depth to water table: About 0 inches
Frequency of flooding: None
Frequency of ponding: Frequent
Calcium carbonate, maximum content: 4 percent
Maximum salinity: Nonsaline to very slightly saline (0.0 to 2.0 mmhos/cm)
Sodium adsorption ratio, maximum: 4.0
Available water supply, 0 to 60 inches: Low (about 5.3 inches)

Interpretive groups

Land capability classification (irrigated): None specified
Land capability classification (nonirrigated): 7w
Hydrologic Soil Group: A/D
Ecological site: R155XY070FL - Sandy Freshwater Isolated Marshes and Swamps
Forage suitability group: Sandy soils on stream terraces, flood plains, or in depressions (G155XB145FL)
Other vegetative classification: Freshwater Marshes and Ponds (R155XY010FL), Sandy soils on stream terraces, flood plains, or in depressions (G155XB145FL)
Hydric soil rating: Yes

Minor Components

Basinger

Percent of map unit: 6 percent
Landform: Drainageways on marine terraces, flats on marine terraces
Landform position (three-dimensional): Tread, dip, talf
Down-slope shape: Concave, convex
Across-slope shape: Linear, concave
Ecological site: R155XY070FL - Sandy Freshwater Isolated Marshes and Swamps
Other vegetative classification: Sandy soils on flats of mesic or hydric lowlands (G155XB141FL), Slough (R155XY011FL)
Hydric soil rating: Yes

Riviera

Percent of map unit: 4 percent
Landform: Depressions on marine terraces
Landform position (three-dimensional): Tread, dip
Down-slope shape: Concave
Across-slope shape: Concave
Ecological site: R155XY080FL - Sandy over Loamy Freshwater Isolated Marshes and Swamps
Other vegetative classification: Freshwater Marshes and Ponds (R155XY010FL), Sandy over loamy soils on stream terraces, flood plains, or in depressions (G155XB245FL)
Hydric soil rating: Yes

Floridana

Percent of map unit: 3 percent
Landform: Depressions on marine terraces
Landform position (three-dimensional): Tread, dip
Down-slope shape: Concave
Across-slope shape: Linear, concave
Ecological site: R155XY080FL - Sandy over Loamy Freshwater Isolated Marshes and Swamps
Other vegetative classification: Sandy over loamy soils on stream terraces, flood plains, or in depressions (G155XB245FL), Freshwater Marshes and Ponds (R155XY010FL)
Hydric soil rating: Yes

Manatee

Percent of map unit: 2 percent
Landform: Depressions on marine terraces
Landform position (three-dimensional): Tread, dip
Down-slope shape: Concave
Across-slope shape: Linear, concave
Ecological site: R155XY090FL - Loamy and Clayey Freshwater Isolated Marshes and Swamps
Other vegetative classification: Loamy and clayey soils on stream terraces, flood plains, or in depressions (G155XB345FL), Freshwater Marshes and Ponds (R155XY010FL)
Hydric soil rating: Yes

35—Hontoon muck, frequently ponded, 0 to 1 percent slopes

Map Unit Setting

National map unit symbol: 2vbpq
Elevation: 0 to 250 feet
Mean annual precipitation: 43 to 63 inches
Mean annual air temperature: 68 to 77 degrees F
Frost-free period: 300 to 365 days
Farmland classification: Not prime farmland

Map Unit Composition

Hontoon and similar soils: 85 percent

Minor components: 15 percent

Estimates are based on observations, descriptions, and transects of the mapunit.

Description of Hontoon

Setting

Landform: Depressions on marine terraces

Landform position (three-dimensional): Tread, dip

Down-slope shape: Concave

Across-slope shape: Concave

Parent material: Herbaceous organic material

Typical profile

Oa - 0 to 75 inches: muck

AC - 75 to 80 inches: sandy loam

Properties and qualities

Slope: 0 to 1 percent

Depth to restrictive feature: More than 80 inches

Drainage class: Very poorly drained

Runoff class: Negligible

Capacity of the most limiting layer to transmit water (Ksat): High to very high (5.95 to 19.98 in/hr)

Depth to water table: About 0 inches

Frequency of flooding: None

Frequency of ponding: Frequent

Maximum salinity: Nonsaline to very slightly saline (0.0 to 2.0 mmhos/cm)

Sodium adsorption ratio, maximum: 4.0

Available water supply, 0 to 60 inches: Very high (about 23.9 inches)

Interpretive groups

Land capability classification (irrigated): None specified

Land capability classification (nonirrigated): 7w

Hydrologic Soil Group: A/D

Forage suitability group: Organic soils in depressions and on flood plains (G154XB645FL)

Other vegetative classification: Organic soils in depressions and on flood plains (G154XB645FL), Freshwater Marshes and Ponds (R154XY010FL)

Hydric soil rating: Yes

Minor Components

Samsula

Percent of map unit: 5 percent

Landform: Depressions on marine terraces

Landform position (three-dimensional): Tread, dip

Down-slope shape: Concave

Across-slope shape: Concave

Other vegetative classification: Organic soils in depressions and on flood plains (G155XB645FL), Freshwater Marshes and Ponds (R155XY010FL)

Hydric soil rating: Yes

Hontoon, drained

Percent of map unit: 5 percent

Custom Soil Resource Report

Landform: Depressions on marine terraces
Landform position (three-dimensional): Tread, dip
Down-slope shape: Concave
Across-slope shape: Concave
Other vegetative classification: Organic soils in depressions and on flood plains (G154XB645FL), Freshwater Marshes and Ponds (R154XY010FL)
Hydric soil rating: Yes

Placid

Percent of map unit: 3 percent
Landform: Drainageways on marine terraces, depressions on marine terraces
Landform position (three-dimensional): Tread, dip
Down-slope shape: Concave
Across-slope shape: Concave
Other vegetative classification: Sandy soils on stream terraces, flood plains, or in depressions (G155XB145FL), Freshwater Marshes and Ponds (R155XY010FL)
Hydric soil rating: Yes

Basinger

Percent of map unit: 2 percent
Landform: Depressions on marine terraces
Landform position (three-dimensional): Tread, dip
Down-slope shape: Concave, linear
Across-slope shape: Concave, linear
Other vegetative classification: Sandy soils on flats of mesic or hydric lowlands (G155XB141FL)
Hydric soil rating: Yes

36—Basinger mucky fine sand, frequently ponded, 0 to 1 percent slopes

Map Unit Setting

National map unit symbol: 2y9hl
Elevation: 50 to 230 feet
Mean annual precipitation: 45 to 55 inches
Mean annual air temperature: 70 to 77 degrees F
Frost-free period: 350 to 365 days
Farmland classification: Not prime farmland

Map Unit Composition

Basinger and similar soils: 85 percent
Minor components: 15 percent
Estimates are based on observations, descriptions, and transects of the mapunit.

Description of Basinger

Setting

Landform: Depressions on marine terraces
Landform position (three-dimensional): Dip, talf
Down-slope shape: Concave, linear

Custom Soil Resource Report

Across-slope shape: Concave, linear
Parent material: Sandy marine deposits

Typical profile

A - 0 to 7 inches: mucky fine sand
E - 7 to 19 inches: fine sand
E/Bh - 19 to 39 inches: fine sand
C - 39 to 80 inches: fine sand

Properties and qualities

Slope: 0 to 1 percent
Depth to restrictive feature: More than 80 inches
Drainage class: Very poorly drained
Runoff class: Negligible
Capacity of the most limiting layer to transmit water (Ksat): High to very high (6.00 to 20.00 in/hr)
Depth to water table: About 0 inches
Frequency of flooding: None
Frequency of ponding: Frequent
Maximum salinity: Nonsaline to very slightly saline (0.0 to 2.0 mmhos/cm)
Sodium adsorption ratio, maximum: 4.0
Available water supply, 0 to 60 inches: Moderate (about 6.3 inches)

Interpretive groups

Land capability classification (irrigated): None specified
Land capability classification (nonirrigated): 7w
Hydrologic Soil Group: A/D
Forage suitability group: Sandy soils on stream terraces, flood plains, or in depressions (G154XB145FL)
Other vegetative classification: Sandy soils on stream terraces, flood plains, or in depressions (G154XB145FL), Freshwater Marshes and Ponds (R154XY010FL)
Hydric soil rating: Yes

Minor Components

Placid

Percent of map unit: 4 percent
Landform: Depressions on marine terraces, drainageways on marine terraces
Landform position (three-dimensional): Tread, dip
Down-slope shape: Concave
Across-slope shape: Concave
Other vegetative classification: Sandy soils on stream terraces, flood plains, or in depressions (G155XB145FL), Freshwater Marshes and Ponds (R155XY010FL)
Hydric soil rating: Yes

Pompano

Percent of map unit: 4 percent
Landform: Drainageways on marine terraces, flats on marine terraces
Landform position (three-dimensional): Tread, dip
Down-slope shape: Linear
Across-slope shape: Concave, linear
Other vegetative classification: Sandy soils on flats of mesic or hydric lowlands (G155XB141FL), Slough (R155XY011FL)
Hydric soil rating: Yes

Samsula

Percent of map unit: 4 percent
Landform: Depressions on marine terraces
Landform position (three-dimensional): Tread, dip
Down-slope shape: Concave
Across-slope shape: Concave
Other vegetative classification: Organic soils in depressions and on flood plains (G155XB645FL), Freshwater Marshes and Ponds (R155XY010FL)
Hydric soil rating: Yes

St. Johns

Percent of map unit: 3 percent
Landform: Depressions on marine terraces, flats on marine terraces
Landform position (three-dimensional): Tread, dip, talf
Down-slope shape: Linear
Across-slope shape: Concave
Other vegetative classification: Sandy soils on flats of mesic or hydric lowlands (G155XB141FL), South Florida Flatwoods (R155XY003FL)
Hydric soil rating: Yes

40—Wauchula fine sand

Map Unit Setting

National map unit symbol: 1jtvq
Elevation: 10 to 180 feet
Mean annual precipitation: 46 to 54 inches
Mean annual air temperature: 70 to 77 degrees F
Frost-free period: 350 to 365 days
Farmland classification: Not prime farmland

Map Unit Composition

Wauchula, non-hydric, and similar soils: 65 percent
Wauchula, hydric, and similar soils: 15 percent
Minor components: 20 percent
Estimates are based on observations, descriptions, and transects of the mapunit.

Description of Wauchula, Non-hydric

Setting

Landform: Flats on marine terraces
Landform position (three-dimensional): Talf
Down-slope shape: Convex
Across-slope shape: Linear
Parent material: Sandy and loamy marine deposits

Typical profile

A - 0 to 7 inches: fine sand
E - 7 to 18 inches: fine sand
Bh - 18 to 26 inches: fine sand
E' - 26 to 33 inches: fine sand

Custom Soil Resource Report

Btg - 33 to 70 inches: sandy clay loam

Cg - 70 to 80 inches: fine sandy loam

Properties and qualities

Slope: 0 to 2 percent

Depth to restrictive feature: More than 80 inches

Drainage class: Poorly drained

Runoff class: High

Capacity of the most limiting layer to transmit water (Ksat): Moderately low to moderately high (0.06 to 0.20 in/hr)

Depth to water table: About 6 to 18 inches

Frequency of flooding: None

Frequency of ponding: None

Maximum salinity: Nonsaline to very slightly saline (0.0 to 2.0 mmhos/cm)

Sodium adsorption ratio, maximum: 4.0

Available water supply, 0 to 60 inches: Moderate (about 7.7 inches)

Interpretive groups

Land capability classification (irrigated): None specified

Land capability classification (nonirrigated): 3w

Hydrologic Soil Group: C/D

Ecological site: F155XY130FL - Sandy over Loamy Flatwoods and Hammocks

Forage suitability group: Sandy over loamy soils on flats of hydric or mesic lowlands (G154XB241FL)

Other vegetative classification: Sandy over loamy soils on flats of hydric or mesic lowlands (G154XB241FL), South Florida Flatwoods (R154XY003FL)

Hydric soil rating: No

Description of Wauchula, Hydric

Setting

Landform: Flats on marine terraces

Landform position (three-dimensional): Talf

Down-slope shape: Linear

Across-slope shape: Linear

Parent material: Sandy and loamy marine deposits

Typical profile

A - 0 to 7 inches: fine sand

E - 7 to 18 inches: fine sand

Bh - 18 to 26 inches: fine sand

E' - 26 to 33 inches: fine sand

Btg - 33 to 70 inches: sandy clay loam

Cg - 70 to 80 inches: fine sandy loam

Properties and qualities

Slope: 0 to 2 percent

Depth to restrictive feature: More than 80 inches

Drainage class: Poorly drained

Runoff class: High

Capacity of the most limiting layer to transmit water (Ksat): Moderately low to moderately high (0.06 to 0.20 in/hr)

Depth to water table: About 0 to 12 inches

Frequency of flooding: None

Frequency of ponding: None

Maximum salinity: Nonsaline to very slightly saline (0.0 to 2.0 mmhos/cm)

Sodium adsorption ratio, maximum: 4.0

Custom Soil Resource Report

Available water supply, 0 to 60 inches: Moderate (about 7.7 inches)

Interpretive groups

Land capability classification (irrigated): None specified

Land capability classification (nonirrigated): 3w

Hydrologic Soil Group: C/D

Ecological site: F155XY130FL - Sandy over Loamy Flatwoods and Hammocks

Forage suitability group: Sandy over loamy soils on flats of hydric or mesic lowlands (G154XB241FL)

Other vegetative classification: Sandy over loamy soils on flats of hydric or mesic lowlands (G154XB241FL), South Florida Flatwoods (R154XY003FL)

Hydric soil rating: Yes

Minor Components

Lynne, non-hydric

Percent of map unit: 7 percent

Landform: Flats on marine terraces

Landform position (three-dimensional): Talf

Down-slope shape: Convex

Across-slope shape: Linear

Ecological site: F155XY130FL - Sandy over Loamy Flatwoods and Hammocks

Other vegetative classification: Sandy over loamy soils on flats of hydric or mesic lowlands (G154XB241FL), South Florida Flatwoods (R154XY003FL)

Hydric soil rating: No

Pompano

Percent of map unit: 7 percent

Landform: Flats on marine terraces, drainageways on marine terraces

Landform position (three-dimensional): Talf, dip

Down-slope shape: Linear

Across-slope shape: Concave

Ecological site: F155XY120FL - Sandy Flatwoods and Hammocks

Other vegetative classification: Sandy soils on flats of mesic or hydric lowlands (G154XB141FL), Slough (R154XY011FL)

Hydric soil rating: Yes

Myakka, non-hydric

Percent of map unit: 6 percent

Landform: Flatwoods on marine terraces

Landform position (three-dimensional): Talf

Down-slope shape: Convex

Across-slope shape: Linear

Ecological site: F155XY120FL - Sandy Flatwoods and Hammocks

Other vegetative classification: Sandy soils on flats of mesic or hydric lowlands (G154XB141FL)

Hydric soil rating: No

42—Felda fine sand

Map Unit Setting

National map unit symbol: 1jtv
Elevation: 20 to 200 feet
Mean annual precipitation: 46 to 54 inches
Mean annual air temperature: 70 to 77 degrees F
Frost-free period: 350 to 365 days
Farmland classification: Not prime farmland

Map Unit Composition

Felda and similar soils: 80 percent
Minor components: 20 percent
Estimates are based on observations, descriptions, and transects of the mapunit.

Description of Felda

Setting

Landform: Drainageways on marine terraces
Landform position (three-dimensional): Dip
Down-slope shape: Linear
Across-slope shape: Concave
Parent material: Sandy and loamy marine deposits

Typical profile

A - 0 to 5 inches: fine sand
Eg - 5 to 22 inches: fine sand
Btg - 22 to 50 inches: sandy clay loam
Cg - 50 to 80 inches: sandy loam

Properties and qualities

Slope: 0 to 2 percent
Depth to restrictive feature: More than 80 inches
Drainage class: Poorly drained
Runoff class: High
Capacity of the most limiting layer to transmit water (Ksat): Moderately high to high
(0.57 to 5.95 in/hr)
Depth to water table: About 0 to 12 inches
Frequency of flooding: None
Frequency of ponding: None
Calcium carbonate, maximum content: 15 percent
Maximum salinity: Nonsaline to very slightly saline (0.0 to 2.0 mmhos/cm)
Sodium adsorption ratio, maximum: 4.0
Available water supply, 0 to 60 inches: Low (about 4.9 inches)

Interpretive groups

Land capability classification (irrigated): None specified
Land capability classification (nonirrigated): 3w
Hydrologic Soil Group: A/D

Custom Soil Resource Report

Ecological site: R155XY080FL - Sandy over Loamy Freshwater Isolated Marshes and Swamps

Forage suitability group: Sandy over loamy soils on flats of hydric or mesic lowlands (G154XB241FL)

Other vegetative classification: Sandy over loamy soils on flats of hydric or mesic lowlands (G154XB241FL), Slough (R154XY011FL)

Hydric soil rating: Yes

Minor Components

Floridana, depressional

Percent of map unit: 5 percent

Landform: Depressions on marine terraces

Landform position (three-dimensional): Dip

Down-slope shape: Concave

Across-slope shape: Concave

Ecological site: R155XY080FL - Sandy over Loamy Freshwater Isolated Marshes and Swamps

Other vegetative classification: Sandy over loamy soils on stream terraces, flood plains, or in depressions (G154XB245FL), Freshwater Marshes and Ponds (R154XY010FL)

Hydric soil rating: Yes

Malabar

Percent of map unit: 5 percent

Landform: Flats on marine terraces, drainageways on marine terraces

Landform position (three-dimensional): Talf, dip

Down-slope shape: Linear

Across-slope shape: Concave

Ecological site: F155XY120FL - Sandy Flatwoods and Hammocks

Other vegetative classification: Sandy soils on flats of mesic or hydric lowlands (G154XB141FL), Slough (R154XY011FL)

Hydric soil rating: Yes

Oldsmar, non-hydric

Percent of map unit: 5 percent

Landform: Flatwoods on marine terraces

Landform position (three-dimensional): Talf

Down-slope shape: Convex

Across-slope shape: Linear

Ecological site: F155XY120FL - Sandy Flatwoods and Hammocks

Other vegetative classification: Sandy soils on flats of mesic or hydric lowlands (G154XB141FL), South Florida Flatwoods (R154XY003FL)

Hydric soil rating: No

Bradenton, hydric

Percent of map unit: 5 percent

Landform: Flats on marine terraces

Landform position (three-dimensional): Talf

Down-slope shape: Linear

Across-slope shape: Linear

Ecological site: F155XY140FL - Loamy and Clayey Hardwood Hammocks

Other vegetative classification: Loamy and clayey soils on flats of hydric or mesic lowlands (G154XB341FL), Upland Hardwood Hammock (R154XY008FL)

Hydric soil rating: Yes

47—Zolfo fine sand, 0 to 2 percent slopes

Map Unit Setting

National map unit symbol: 2w0q1
Elevation: 30 to 160 feet
Mean annual precipitation: 44 to 56 inches
Mean annual air temperature: 68 to 77 degrees F
Frost-free period: 350 to 365 days
Farmland classification: Farmland of unique importance

Map Unit Composition

Zolfo and similar soils: 85 percent
Minor components: 15 percent
Estimates are based on observations, descriptions, and transects of the mapunit.

Description of Zolfo

Setting

Landform: Flatwoods on marine terraces, rises on marine terraces
Landform position (two-dimensional): Summit
Landform position (three-dimensional): Tread, rise
Down-slope shape: Linear, convex
Across-slope shape: Linear
Parent material: Sandy marine deposits

Typical profile

A - 0 to 5 inches: fine sand
E - 5 to 59 inches: fine sand
Bh - 59 to 80 inches: fine sand

Properties and qualities

Slope: 0 to 2 percent
Depth to restrictive feature: More than 80 inches
Drainage class: Somewhat poorly drained
Runoff class: Very low
Capacity of the most limiting layer to transmit water (Ksat): Moderately high to high
(0.60 to 2.00 in/hr)
Depth to water table: About 18 to 42 inches
Frequency of flooding: None
Frequency of ponding: None
Maximum salinity: Nonsaline to very slightly saline (0.0 to 2.0 mmhos/cm)
Sodium adsorption ratio, maximum: 4.0
Available water supply, 0 to 60 inches: Low (about 4.8 inches)

Interpretive groups

Land capability classification (irrigated): None specified
Land capability classification (nonirrigated): 3w
Hydrologic Soil Group: A
Forage suitability group: Sandy soils on rises and knolls of mesic uplands
(G155XB131FL)

Custom Soil Resource Report

Other vegetative classification: Sandy soils on rises and knolls of mesic uplands (G155XB131FL), South Florida Flatwoods (R155XY003FL)
Hydric soil rating: No

Minor Components

Myakka

Percent of map unit: 5 percent
Landform: Drainageways on flatwoods on marine terraces
Landform position (three-dimensional): Tread, talf, dip
Down-slope shape: Linear
Across-slope shape: Linear, concave
Other vegetative classification: Sandy soils on flats of mesic or hydric lowlands (G155XB141FL), South Florida Flatwoods (R155XY003FL)
Hydric soil rating: No

Millhopper

Percent of map unit: 4 percent
Landform: Flatwoods on marine terraces, rises on marine terraces
Landform position (two-dimensional): Summit
Landform position (three-dimensional): Tread, talf, rise
Down-slope shape: Convex
Across-slope shape: Linear
Other vegetative classification: Sandy soils on rises, knolls, and ridges of mesic uplands (G155XB121FL)
Hydric soil rating: No

Tavares

Percent of map unit: 4 percent
Landform: Flatwoods on marine terraces, knolls on marine terraces, rises on marine terraces
Landform position (two-dimensional): Summit
Landform position (three-dimensional): Interfluve, side slope, tread, rise
Down-slope shape: Convex, linear
Across-slope shape: Linear, convex
Other vegetative classification: Sandy soils on rises, knolls, and ridges of mesic uplands (G155XB121FL), Longleaf Pine-Turkey Oak Hills (R155XY002FL), Sand Pine Scrub (R155XY001FL)
Hydric soil rating: No

Malabar

Percent of map unit: 2 percent
Landform: — error in exists on —
Landform position (three-dimensional): Tread, talf, dip
Down-slope shape: Linear, concave
Across-slope shape: Linear, concave
Other vegetative classification: Sandy soils on flats of mesic or hydric lowlands (G155XB141FL), Slough (R155XY011FL)
Hydric soil rating: Yes

49—Adamsville-Urban land complex

Map Unit Setting

National map unit symbol: 1jtvz
Elevation: 10 to 120 feet
Mean annual precipitation: 46 to 54 inches
Mean annual air temperature: 70 to 77 degrees F
Frost-free period: 350 to 365 days
Farmland classification: Not prime farmland

Map Unit Composition

Adamsville and similar soils: 60 percent
Urban land: 30 percent
Minor components: 10 percent
Estimates are based on observations, descriptions, and transects of the mapunit.

Description of Adamsville

Setting

Landform: Flats on marine terraces, rises on marine terraces
Landform position (three-dimensional): Interfluve, talf
Down-slope shape: Convex
Across-slope shape: Linear
Parent material: Sandy marine deposits

Typical profile

A - 0 to 6 inches: fine sand
C - 6 to 80 inches: fine sand

Properties and qualities

Slope: 0 to 2 percent
Depth to restrictive feature: More than 80 inches
Drainage class: Somewhat poorly drained
Runoff class: Negligible
Capacity of the most limiting layer to transmit water (Ksat): High to very high (5.95 to 19.98 in/hr)
Depth to water table: About 24 to 42 inches
Frequency of flooding: None
Frequency of ponding: None
Maximum salinity: Nonsaline to very slightly saline (0.0 to 2.0 mmhos/cm)
Sodium adsorption ratio, maximum: 4.0
Available water supply, 0 to 60 inches: Low (about 3.7 inches)

Interpretive groups

Land capability classification (irrigated): None specified
Land capability classification (nonirrigated): 3w
Hydrologic Soil Group: A
Ecological site: F155XY150FL - Sandy Upland Mesic Flatwoods and Hammocks on Rises and Knolls
Forage suitability group: Forage suitability group not assigned (G154XB999FL)

Custom Soil Resource Report

Other vegetative classification: Forage suitability group not assigned (G154XB999FL)
Hydric soil rating: No

Description of Urban Land

Setting

Landform: Marine terraces
Landform position (three-dimensional): Interfluve, talf
Down-slope shape: Linear
Across-slope shape: Linear
Parent material: No parent material

Interpretive groups

Land capability classification (irrigated): None specified
Ecological site: F155XY150FL - Sandy Upland Mesic Flatwoods and Hammocks on Rises and Knolls
Forage suitability group: Forage suitability group not assigned (G154XB999FL)
Other vegetative classification: Forage suitability group not assigned (G154XB999FL)
Hydric soil rating: Unranked

Minor Components

Satellite

Percent of map unit: 5 percent
Landform: Knolls on marine terraces, ridges on marine terraces
Landform position (three-dimensional): Interfluve
Down-slope shape: Convex
Across-slope shape: Linear
Ecological site: R155XY180FL - Sandy Scrub on Rises, Ridges, and Knolls of Mesic Uplands
Other vegetative classification: Forage suitability group not assigned (G154XB999FL), Sand Pine Scrub (R154XY001FL)
Hydric soil rating: No

Tavares

Percent of map unit: 5 percent
Landform: Knolls on marine terraces, ridges on marine terraces
Landform position (three-dimensional): Interfluve
Down-slope shape: Convex
Across-slope shape: Linear
Ecological site: R155XY180FL - Sandy Scrub on Rises, Ridges, and Knolls of Mesic Uplands
Other vegetative classification: Forage suitability group not assigned (G154XB999FL), Longleaf Pine-Turkey Oak Hills (R154XY002FL)
Hydric soil rating: No

50—Candler-Urban land complex, 0 to 5 percent slopes

Map Unit Setting

National map unit symbol: 1jtw0
Elevation: 50 to 150 feet
Mean annual precipitation: 46 to 54 inches
Mean annual air temperature: 70 to 77 degrees F
Frost-free period: 350 to 365 days
Farmland classification: Not prime farmland

Map Unit Composition

Candler and similar soils: 55 percent
Urban land: 45 percent
Estimates are based on observations, descriptions, and transects of the mapunit.

Description of Candler

Setting

Landform: Knolls on marine terraces, ridges on marine terraces
Landform position (three-dimensional): Interfluve
Down-slope shape: Convex
Across-slope shape: Convex
Parent material: Eolian deposits and/or sandy and loamy marine deposits

Typical profile

A - 0 to 6 inches: sand
E - 6 to 63 inches: sand
E and Bt - 63 to 80 inches: sand

Properties and qualities

Slope: 0 to 5 percent
Depth to restrictive feature: More than 80 inches
Drainage class: Excessively drained
Runoff class: Negligible
Capacity of the most limiting layer to transmit water (Ksat): High to very high (5.95 to 19.98 in/hr)
Depth to water table: More than 80 inches
Frequency of flooding: None
Frequency of ponding: None
Maximum salinity: Nonsaline to very slightly saline (0.0 to 2.0 mmhos/cm)
Sodium adsorption ratio, maximum: 4.0
Available water supply, 0 to 60 inches: Very low (about 2.5 inches)

Interpretive groups

Land capability classification (irrigated): None specified
Land capability classification (nonirrigated): 4s
Hydrologic Soil Group: A
Forage suitability group: Forage suitability group not assigned (G154XB999FL)

Custom Soil Resource Report

Other vegetative classification: Forage suitability group not assigned
(G154XB999FL)
Hydric soil rating: No

Description of Urban Land

Setting

Landform: Marine terraces
Landform position (three-dimensional): Interfluve, talf
Down-slope shape: Linear
Across-slope shape: Linear
Parent material: No parent material

Interpretive groups

Land capability classification (irrigated): None specified
Forage suitability group: Forage suitability group not assigned (G154XB999FL)
Other vegetative classification: Forage suitability group not assigned
(G154XB999FL)
Hydric soil rating: Unranked

51—Pomona-Urban land complex

Map Unit Setting

National map unit symbol: 1jtw1
Elevation: 20 to 120 feet
Mean annual precipitation: 46 to 54 inches
Mean annual air temperature: 70 to 77 degrees F
Frost-free period: 350 to 365 days
Farmland classification: Not prime farmland

Map Unit Composition

Pomona, non-hydric, and similar soils: 45 percent
Urban land: 30 percent
Pomona, hydric, and similar soils: 10 percent
Minor components: 15 percent
Estimates are based on observations, descriptions, and transects of the mapunit.

Description of Pomona, Non-hydric

Setting

Landform: Flats on marine terraces
Landform position (three-dimensional): Talf
Down-slope shape: Convex
Across-slope shape: Linear
Parent material: Sandy and loamy marine deposits

Typical profile

A - 0 to 6 inches: fine sand
E - 6 to 21 inches: sand
Bh - 21 to 26 inches: loamy fine sand
E' - 26 to 48 inches: fine sand

Custom Soil Resource Report

Btg - 48 to 73 inches: fine sandy loam

Cg - 73 to 80 inches: loamy sand

Properties and qualities

Slope: 0 to 2 percent

Depth to restrictive feature: More than 80 inches

Drainage class: Poorly drained

Runoff class: High

*Capacity of the most limiting layer to transmit water (Ksat): Moderately high to high
(0.20 to 1.98 in/hr)*

Depth to water table: About 6 to 18 inches

Frequency of flooding: None

Frequency of ponding: None

Maximum salinity: Nonsaline to very slightly saline (0.0 to 2.0 mmhos/cm)

Sodium adsorption ratio, maximum: 4.0

Available water supply, 0 to 60 inches: Low (about 5.7 inches)

Interpretive groups

Land capability classification (irrigated): None specified

Land capability classification (nonirrigated): 4w

Hydrologic Soil Group: A/D

Ecological site: F155XY120FL - Sandy Flatwoods and Hammocks

Forage suitability group: Forage suitability group not assigned (G154XB999FL)

*Other vegetative classification: Forage suitability group not assigned
(G154XB999FL)*

Hydric soil rating: No

Description of Urban Land

Setting

Landform: Marine terraces

Landform position (three-dimensional): Interfluve, talf

Down-slope shape: Linear

Across-slope shape: Linear

Parent material: No parent material

Interpretive groups

Land capability classification (irrigated): None specified

Ecological site: F155XY120FL - Sandy Flatwoods and Hammocks

Forage suitability group: Forage suitability group not assigned (G154XB999FL)

*Other vegetative classification: Forage suitability group not assigned
(G154XB999FL)*

Hydric soil rating: Unranked

Description of Pomona, Hydric

Setting

Landform: Flats on marine terraces

Landform position (three-dimensional): Talf

Down-slope shape: Linear

Across-slope shape: Linear

Parent material: Sandy and loamy marine deposits

Typical profile

A - 0 to 6 inches: fine sand

E - 6 to 21 inches: sand

Bh - 21 to 26 inches: loamy fine sand

Custom Soil Resource Report

E' - 26 to 48 inches: fine sand
Btg - 48 to 73 inches: fine sandy loam
Cg - 73 to 80 inches: loamy sand

Properties and qualities

Slope: 0 to 2 percent
Depth to restrictive feature: More than 80 inches
Drainage class: Poorly drained
Runoff class: High
Capacity of the most limiting layer to transmit water (Ksat): Moderately high to high (0.20 to 1.98 in/hr)
Depth to water table: About 0 to 12 inches
Frequency of flooding: None
Frequency of ponding: None
Maximum salinity: Nonsaline to very slightly saline (0.0 to 2.0 mmhos/cm)
Sodium adsorption ratio, maximum: 4.0
Available water supply, 0 to 60 inches: Low (about 5.7 inches)

Interpretive groups

Land capability classification (irrigated): None specified
Land capability classification (nonirrigated): 4w
Hydrologic Soil Group: A/D
Ecological site: F155XY120FL - Sandy Flatwoods and Hammocks
Forage suitability group: Forage suitability group not assigned (G154XB999FL)
Other vegetative classification: Forage suitability group not assigned (G154XB999FL)
Hydric soil rating: Yes

Minor Components

Myakka

Percent of map unit: 5 percent
Landform: Flatwoods on marine terraces
Landform position (three-dimensional): Talf
Down-slope shape: Convex
Across-slope shape: Linear
Ecological site: F155XY120FL - Sandy Flatwoods and Hammocks
Other vegetative classification: Forage suitability group not assigned (G154XB999FL), South Florida Flatwoods (R154XY003FL)
Hydric soil rating: No

Immokalee

Percent of map unit: 5 percent
Landform: Flatwoods on marine terraces
Landform position (three-dimensional): Talf
Down-slope shape: Convex
Across-slope shape: Linear
Ecological site: F155XY120FL - Sandy Flatwoods and Hammocks
Other vegetative classification: Forage suitability group not assigned (G154XB999FL)
Hydric soil rating: No

Wauchula, non-hydric

Percent of map unit: 5 percent
Landform: Flats on marine terraces
Landform position (three-dimensional): Talf
Down-slope shape: Convex

Custom Soil Resource Report

Across-slope shape: Linear
Ecological site: F155XY130FL - Sandy over Loamy Flatwoods and Hammocks
Other vegetative classification: Forage suitability group not assigned
(G154XB999FL), South Florida Flatwoods (R154XY003FL)
Hydric soil rating: No

53—Myakka-Immokolee-Urban land complex

Map Unit Setting

National map unit symbol: 1jtw2
Elevation: 20 to 210 feet
Mean annual precipitation: 46 to 54 inches
Mean annual air temperature: 70 to 77 degrees F
Frost-free period: 350 to 365 days
Farmland classification: Not prime farmland

Map Unit Composition

Myakka, non-hydric, and similar soils: 30 percent
Urban land: 25 percent
Immokalee and similar soils: 25 percent
Myakka, hydric, and similar soils: 10 percent
Minor components: 10 percent
Estimates are based on observations, descriptions, and transects of the mapunit.

Description of Myakka, Non-hydric

Setting

Landform: Flatwoods on marine terraces
Landform position (three-dimensional): Talf
Down-slope shape: Convex
Across-slope shape: Linear
Parent material: Sandy marine deposits

Typical profile

A - 0 to 7 inches: fine sand
E - 7 to 25 inches: fine sand
Bh - 25 to 36 inches: fine sand
C - 36 to 80 inches: fine sand

Properties and qualities

Slope: 0 to 2 percent
Depth to restrictive feature: More than 80 inches
Drainage class: Poorly drained
Runoff class: High
Capacity of the most limiting layer to transmit water (Ksat): Moderately high to high
(0.57 to 5.95 in/hr)
Depth to water table: About 6 to 18 inches
Frequency of flooding: None

Custom Soil Resource Report

Frequency of ponding: None

Maximum salinity: Nonsaline to very slightly saline (0.0 to 2.0 mmhos/cm)

Sodium adsorption ratio, maximum: 4.0

Available water supply, 0 to 60 inches: Low (about 5.6 inches)

Interpretive groups

Land capability classification (irrigated): None specified

Land capability classification (nonirrigated): 4w

Hydrologic Soil Group: A/D

Ecological site: F155XY120FL - Sandy Flatwoods and Hammocks

Forage suitability group: Forage suitability group not assigned (G154XB999FL)

Other vegetative classification: Forage suitability group not assigned
(G154XB999FL)

Hydric soil rating: No

Description of Urban Land

Setting

Landform: Marine terraces

Landform position (three-dimensional): Interfluve, talf

Down-slope shape: Linear

Across-slope shape: Linear

Parent material: No parent material

Interpretive groups

Land capability classification (irrigated): None specified

Ecological site: F155XY120FL - Sandy Flatwoods and Hammocks

Forage suitability group: Forage suitability group not assigned (G154XB999FL)

Other vegetative classification: Forage suitability group not assigned
(G154XB999FL)

Hydric soil rating: Unranked

Description of Immokalee

Setting

Landform: Flatwoods on marine terraces

Landform position (three-dimensional): Talf

Down-slope shape: Convex

Across-slope shape: Linear

Parent material: Sandy marine deposits

Typical profile

A - 0 to 7 inches: sand

E - 7 to 39 inches: sand

Bh - 39 to 58 inches: sand

E' - 58 to 66 inches: sand

B'h - 66 to 80 inches: sand

Properties and qualities

Slope: 0 to 2 percent

Depth to restrictive feature: More than 80 inches

Drainage class: Poorly drained

Runoff class: High

Capacity of the most limiting layer to transmit water (Ksat): Moderately high to high
(0.57 to 1.98 in/hr)

Depth to water table: About 6 to 18 inches

Frequency of flooding: None

Custom Soil Resource Report

Frequency of ponding: None

Maximum salinity: Nonsaline to very slightly saline (0.0 to 2.0 mmhos/cm)

Sodium adsorption ratio, maximum: 4.0

Available water supply, 0 to 60 inches: Low (about 5.3 inches)

Interpretive groups

Land capability classification (irrigated): None specified

Land capability classification (nonirrigated): 4w

Hydrologic Soil Group: B/D

Ecological site: F155XY120FL - Sandy Flatwoods and Hammocks

Forage suitability group: Forage suitability group not assigned (G154XB999FL)

Other vegetative classification: Forage suitability group not assigned (G154XB999FL)

Hydric soil rating: No

Description of Myakka, Hydric

Setting

Landform: Flats on marine terraces

Landform position (three-dimensional): Talf

Down-slope shape: Linear

Across-slope shape: Linear

Parent material: Sandy marine deposits

Typical profile

A - 0 to 7 inches: fine sand

E - 7 to 25 inches: fine sand

Bh - 25 to 36 inches: fine sand

C - 36 to 80 inches: fine sand

Properties and qualities

Slope: 0 to 2 percent

Depth to restrictive feature: More than 80 inches

Drainage class: Poorly drained

Runoff class: High

Capacity of the most limiting layer to transmit water (Ksat): Moderately high to high (0.57 to 5.95 in/hr)

Depth to water table: About 0 to 12 inches

Frequency of flooding: None

Frequency of ponding: None

Maximum salinity: Nonsaline to very slightly saline (0.0 to 2.0 mmhos/cm)

Sodium adsorption ratio, maximum: 4.0

Available water supply, 0 to 60 inches: Low (about 5.6 inches)

Interpretive groups

Land capability classification (irrigated): None specified

Land capability classification (nonirrigated): 4w

Hydrologic Soil Group: A/D

Ecological site: F155XY120FL - Sandy Flatwoods and Hammocks

Forage suitability group: Forage suitability group not assigned (G154XB999FL)

Other vegetative classification: Forage suitability group not assigned (G154XB999FL)

Hydric soil rating: Yes

Minor Components

Ona, non-hydric

Percent of map unit: 3 percent
Landform: Flats on marine terraces
Landform position (three-dimensional): Talf
Down-slope shape: Convex
Across-slope shape: Linear
Ecological site: F155XY120FL - Sandy Flatwoods and Hammocks
Other vegetative classification: Forage suitability group not assigned
(G154XB999FL), South Florida Flatwoods (R154XY003FL)
Hydric soil rating: No

Basinger

Percent of map unit: 3 percent
Landform: Drainageways on marine terraces
Landform position (three-dimensional): Dip
Down-slope shape: Linear
Across-slope shape: Concave
Ecological site: F155XY120FL - Sandy Flatwoods and Hammocks
Other vegetative classification: Forage suitability group not assigned
(G154XB999FL), Slough (R154XY011FL)
Hydric soil rating: Yes

Pomello

Percent of map unit: 2 percent
Landform: Knolls on marine terraces, ridges on marine terraces
Landform position (three-dimensional): Interfluve, rise
Down-slope shape: Convex
Across-slope shape: Linear
Ecological site: F155XY150FL - Sandy Upland Mesic Flatwoods and Hammocks
on Rises and Knolls
Other vegetative classification: Sandy soils on rises and knolls of mesic uplands
(G154XB131FL), Sand Pine Scrub (R154XY001FL)
Hydric soil rating: No

Pomona, non-hydric

Percent of map unit: 2 percent
Landform: Flats on marine terraces
Landform position (three-dimensional): Talf
Down-slope shape: Convex
Across-slope shape: Linear
Ecological site: F155XY120FL - Sandy Flatwoods and Hammocks
Other vegetative classification: Forage suitability group not assigned
(G154XB999FL), South Florida Flatwoods (R154XY003FL)
Hydric soil rating: No

55—Sparr-Urban land complex, 0 to 5 percent slopes

Map Unit Setting

National map unit symbol: 1jtw4
Elevation: 20 to 150 feet
Mean annual precipitation: 46 to 54 inches
Mean annual air temperature: 70 to 77 degrees F
Frost-free period: 350 to 365 days
Farmland classification: Not prime farmland

Map Unit Composition

Sparr and similar soils: 50 percent
Urban land: 35 percent
Minor components: 15 percent
Estimates are based on observations, descriptions, and transects of the mapunit.

Description of Sparr

Setting

Landform: Flats on marine terraces, rises on marine terraces
Landform position (three-dimensional): Interfluve, rise
Down-slope shape: Convex
Across-slope shape: Linear
Parent material: Sandy and loamy marine deposits

Typical profile

A - 0 to 8 inches: sand
E - 8 to 57 inches: sand
Bt - 57 to 80 inches: sandy clay loam

Properties and qualities

Slope: 0 to 5 percent
Depth to restrictive feature: More than 80 inches
Drainage class: Somewhat poorly drained
Runoff class: Negligible
Capacity of the most limiting layer to transmit water (Ksat): Moderately high to high
(0.57 to 1.98 in/hr)
Depth to water table: About 18 to 42 inches
Frequency of flooding: None
Frequency of ponding: None
Maximum salinity: Nonsaline to very slightly saline (0.0 to 2.0 mmhos/cm)
Sodium adsorption ratio, maximum: 4.0
Available water supply, 0 to 60 inches: Low (about 4.6 inches)

Interpretive groups

Land capability classification (irrigated): None specified

Custom Soil Resource Report

Land capability classification (nonirrigated): 3w
Hydrologic Soil Group: A/D
Forage suitability group: Forage suitability group not assigned (G154XB999FL)
Other vegetative classification: Forage suitability group not assigned (G154XB999FL)
Hydric soil rating: No

Description of Urban Land

Setting

Landform: Marine terraces
Landform position (three-dimensional): Interfluve, talus
Down-slope shape: Linear
Across-slope shape: Linear
Parent material: No parent material

Interpretive groups

Land capability classification (irrigated): None specified
Forage suitability group: Forage suitability group not assigned (G154XB999FL)
Other vegetative classification: Forage suitability group not assigned (G154XB999FL)
Hydric soil rating: Unranked

Minor Components

Millhopper

Percent of map unit: 4 percent
Landform: Knolls on marine terraces, ridges on marine terraces
Landform position (three-dimensional): Interfluve
Down-slope shape: Convex
Across-slope shape: Linear
Other vegetative classification: Forage suitability group not assigned (G154XB999FL), Upland Hardwood Hammock (R154XY008FL)
Hydric soil rating: No

Apopka

Percent of map unit: 4 percent
Landform: Knolls on marine terraces, ridges on marine terraces
Landform position (three-dimensional): Interfluve, side slope
Down-slope shape: Convex
Across-slope shape: Linear
Other vegetative classification: Forage suitability group not assigned (G154XB999FL), Longleaf Pine-Turkey Oak Hills (R154XY002FL)
Hydric soil rating: No

Candler

Percent of map unit: 4 percent
Landform: Knolls on marine terraces, ridges on marine terraces
Landform position (three-dimensional): Interfluve
Down-slope shape: Convex
Across-slope shape: Convex
Other vegetative classification: Forage suitability group not assigned (G154XB999FL), Longleaf Pine-Turkey Oak Hills (R154XY002FL)
Hydric soil rating: No

Tavares

Percent of map unit: 3 percent

Custom Soil Resource Report

Landform: Knolls on marine terraces, ridges on marine terraces
Landform position (three-dimensional): Interfluve
Down-slope shape: Convex
Across-slope shape: Linear
Other vegetative classification: Forage suitability group not assigned
(G154XB999FL), Longleaf Pine-Turkey Oak Hills (R154XY002FL)
Hydric soil rating: No

58—Udorthents, excavated

Map Unit Setting

National map unit symbol: 1jtw6
Elevation: 50 to 250 feet
Mean annual precipitation: 46 to 54 inches
Mean annual air temperature: 70 to 77 degrees F
Frost-free period: 350 to 365 days
Farmland classification: Not prime farmland

Map Unit Composition

Udorthents, excavated, and similar soils: 100 percent
Estimates are based on observations, descriptions, and transects of the mapunit.

Description of Udorthents, Excavated

Setting

Landform: Marine terraces
Landform position (three-dimensional): Interfluve
Down-slope shape: Convex
Across-slope shape: Linear
Parent material: Altered marine deposits

Properties and qualities

Slope: 1 to 4 percent
Depth to restrictive feature: More than 80 inches
Depth to water table: More than 80 inches
Frequency of flooding: None
Frequency of ponding: None

Interpretive groups

Land capability classification (irrigated): None specified
Land capability classification (nonirrigated): 8
Forage suitability group: Forage suitability group not assigned (G154XB999FL)
Other vegetative classification: Forage suitability group not assigned
(G154XB999FL)
Hydric soil rating: No

59—Arents-Urban land complex, 0 to 5 percent slopes

Map Unit Setting

National map unit symbol: 1jtw7
Elevation: 50 to 210 feet
Mean annual precipitation: 46 to 54 inches
Mean annual air temperature: 70 to 77 degrees F
Frost-free period: 350 to 365 days
Farmland classification: Not prime farmland

Map Unit Composition

Arents and similar soils: 55 percent
Urban land: 45 percent
Estimates are based on observations, descriptions, and transects of the mapunit.

Description of Arents

Setting

Landform: Rises on marine terraces
Landform position (three-dimensional): Rise
Down-slope shape: Convex
Across-slope shape: Linear
Parent material: Altered marine deposits

Typical profile

C - 0 to 80 inches: sand

Properties and qualities

Slope: 0 to 5 percent
Depth to restrictive feature: More than 80 inches
Drainage class: Somewhat poorly drained
Runoff class: Negligible
Capacity of the most limiting layer to transmit water (Ksat): High to very high (5.95 to 19.98 in/hr)
Depth to water table: About 18 to 36 inches
Frequency of flooding: None
Frequency of ponding: None
Maximum salinity: Nonsaline to very slightly saline (0.0 to 2.0 mmhos/cm)
Sodium adsorption ratio, maximum: 4.0
Available water supply, 0 to 60 inches: Very low (about 3.0 inches)

Interpretive groups

Land capability classification (irrigated): None specified
Land capability classification (nonirrigated): 6s
Hydrologic Soil Group: A
Forage suitability group: Forage suitability group not assigned (G154XB999FL)
Other vegetative classification: Forage suitability group not assigned (G154XB999FL)
Hydric soil rating: No

Description of Urban Land

Setting

Landform: Marine terraces
Landform position (three-dimensional): Interfluve, talf
Down-slope shape: Linear
Across-slope shape: Linear
Parent material: No parent material

Interpretive groups

Land capability classification (irrigated): None specified
Forage suitability group: Forage suitability group not assigned (G154XB999FL)
Other vegetative classification: Forage suitability group not assigned (G154XB999FL)
Hydric soil rating: Unranked

60—Arents, sandy

Map Unit Setting

National map unit symbol: 1jtw8
Elevation: 80 to 230 feet
Mean annual precipitation: 46 to 54 inches
Mean annual air temperature: 70 to 77 degrees F
Frost-free period: 350 to 365 days
Farmland classification: Not prime farmland

Map Unit Composition

Arents, sandy, and similar soils: 100 percent
Estimates are based on observations, descriptions, and transects of the mapunit.

Description of Arents, Sandy

Setting

Landform: Rises on marine terraces
Landform position (three-dimensional): Rise
Down-slope shape: Convex
Across-slope shape: Linear
Parent material: Altered marine deposits

Typical profile

AC - 0 to 80 inches: sand

Properties and qualities

Slope: 0 to 2 percent
Depth to restrictive feature: More than 80 inches
Drainage class: Moderately well drained
Runoff class: Negligible
Capacity of the most limiting layer to transmit water (Ksat): Very high (19.98 to 50.02 in/hr)
Depth to water table: About 24 to 48 inches

Custom Soil Resource Report

Frequency of flooding: None
Frequency of ponding: None
Maximum salinity: Nonsaline to very slightly saline (0.0 to 2.0 mmhos/cm)
Sodium adsorption ratio, maximum: 4.0
Available water supply, 0 to 60 inches: Very low (about 2.4 inches)

Interpretive groups

Land capability classification (irrigated): None specified
Land capability classification (nonirrigated): 7s
Hydrologic Soil Group: A
Forage suitability group: Forage suitability group not assigned (G154XB999FL)
Other vegetative classification: Forage suitability group not assigned (G154XB999FL)
Hydric soil rating: No

61—Arents, organic substratum-Urban land complex

Map Unit Setting

National map unit symbol: 1jtw9
Elevation: 50 to 180 feet
Mean annual precipitation: 46 to 54 inches
Mean annual air temperature: 70 to 77 degrees F
Frost-free period: 350 to 365 days
Farmland classification: Not prime farmland

Map Unit Composition

Arents, organic substratum, and similar soils: 51 percent
Urban land: 49 percent
Estimates are based on observations, descriptions, and transects of the mapunit.

Description of Arents, Organic Substratum

Setting

Landform: Flats on marine terraces
Landform position (three-dimensional): Talf
Down-slope shape: Convex
Across-slope shape: Linear
Parent material: Sandy dredge spoils over organic material over sandy marine deposits

Typical profile

C - 0 to 30 inches: sand
Oa - 30 to 65 inches: muck
Cg - 65 to 80 inches: sand

Properties and qualities

Slope: 0 to 2 percent
Depth to restrictive feature: More than 80 inches
Drainage class: Somewhat poorly drained
Runoff class: Negligible
Capacity of the most limiting layer to transmit water (Ksat): High to very high (5.95 to 19.98 in/hr)

Custom Soil Resource Report

Depth to water table: About 24 to 36 inches
Frequency of flooding: None
Frequency of ponding: None
Maximum salinity: Nonsaline to very slightly saline (0.0 to 2.0 mmhos/cm)
Sodium adsorption ratio, maximum: 4.0
Available water supply, 0 to 60 inches: Very high (about 13.8 inches)

Interpretive groups

Land capability classification (irrigated): None specified
Land capability classification (nonirrigated): 6s
Hydrologic Soil Group: A
Forage suitability group: Forage suitability group not assigned (G154XB999FL)
Other vegetative classification: Forage suitability group not assigned (G154XB999FL)
Hydric soil rating: No

Description of Urban Land

Setting

Landform: Marine terraces
Landform position (three-dimensional): Interfluve, talf
Down-slope shape: Linear
Across-slope shape: Linear
Parent material: No parent material

Interpretive groups

Land capability classification (irrigated): None specified
Forage suitability group: Forage suitability group not assigned (G154XB999FL)
Other vegetative classification: Forage suitability group not assigned (G154XB999FL)
Hydric soil rating: Unranked

63—Tavares-Urban land complex

Map Unit Setting

National map unit symbol: 1jtwc
Elevation: 20 to 120 feet
Mean annual precipitation: 46 to 54 inches
Mean annual air temperature: 70 to 77 degrees F
Frost-free period: 350 to 365 days
Farmland classification: Not prime farmland

Map Unit Composition

Tavares and similar soils: 75 percent
Urban land: 25 percent
Estimates are based on observations, descriptions, and transects of the mapunit.

Description of Tavares

Setting

Landform: Rises on marine terraces, flats on marine terraces

Custom Soil Resource Report

Landform position (three-dimensional): Talf
Down-slope shape: Convex
Across-slope shape: Linear
Parent material: Eolian or sandy marine deposits

Typical profile

A - 0 to 8 inches: fine sand
C - 8 to 80 inches: fine sand

Properties and qualities

Slope: 0 to 2 percent
Depth to restrictive feature: More than 80 inches
Drainage class: Moderately well drained
Runoff class: Negligible
Capacity of the most limiting layer to transmit water (Ksat): High to very high (5.95 to 50.02 in/hr)
Depth to water table: About 42 to 72 inches
Frequency of flooding: None
Frequency of ponding: None
Maximum salinity: Nonsaline to very slightly saline (0.0 to 2.0 mmhos/cm)
Sodium adsorption ratio, maximum: 4.0
Available water supply, 0 to 60 inches: Very low (about 2.7 inches)

Interpretive groups

Land capability classification (irrigated): None specified
Land capability classification (nonirrigated): 3s
Hydrologic Soil Group: A
Forage suitability group: Forage suitability group not assigned (G154XB999FL)
Other vegetative classification: Forage suitability group not assigned (G154XB999FL)
Hydric soil rating: No

Description of Urban Land

Setting

Landform: Marine terraces
Landform position (three-dimensional): Interfluve, talf
Down-slope shape: Linear
Across-slope shape: Linear
Parent material: No parent material

Interpretive groups

Land capability classification (irrigated): None specified
Forage suitability group: Forage suitability group not assigned (G154XB999FL)
Other vegetative classification: Forage suitability group not assigned (G154XB999FL)
Hydric soil rating: Unranked

66—Fort Meade-Urban land complex, 0 to 5 percent slopes

Map Unit Setting

National map unit symbol: 1jtwf
Elevation: 100 to 250 feet
Mean annual precipitation: 46 to 54 inches
Mean annual air temperature: 70 to 77 degrees F
Frost-free period: 350 to 365 days
Farmland classification: Not prime farmland

Map Unit Composition

Fort meade and similar soils: 55 percent
Urban land: 45 percent
Estimates are based on observations, descriptions, and transects of the mapunit.

Description of Fort Meade

Setting

Landform: Ridges on marine terraces
Landform position (three-dimensional): Interfluve
Down-slope shape: Convex
Across-slope shape: Linear
Parent material: Sandy marine deposits

Typical profile

A - 0 to 25 inches: sand
C - 25 to 80 inches: sand

Properties and qualities

Slope: 0 to 5 percent
Depth to restrictive feature: More than 80 inches
Drainage class: Well drained
Runoff class: Negligible
Capacity of the most limiting layer to transmit water (Ksat): High to very high (5.95 to 19.98 in/hr)
Depth to water table: More than 80 inches
Frequency of flooding: None
Frequency of ponding: None
Maximum salinity: Nonsaline to very slightly saline (0.0 to 2.0 mmhos/cm)
Sodium adsorption ratio, maximum: 4.0
Available water supply, 0 to 60 inches: Low (about 5.8 inches)

Interpretive groups

Land capability classification (irrigated): None specified
Land capability classification (nonirrigated): 3s
Hydrologic Soil Group: A
Forage suitability group: Forage suitability group not assigned (G154XB999FL)
Other vegetative classification: Forage suitability group not assigned (G154XB999FL)
Hydric soil rating: No

Description of Urban Land

Setting

Landform: Marine terraces
Landform position (three-dimensional): Interfluve, talf
Down-slope shape: Linear
Across-slope shape: Linear
Parent material: No parent material

Interpretive groups

Land capability classification (irrigated): None specified
Forage suitability group: Forage suitability group not assigned (G154XB999FL)
Other vegetative classification: Forage suitability group not assigned (G154XB999FL)
Hydric soil rating: Unranked

68—Arents, 0 to 5 percent slopes

Map Unit Setting

National map unit symbol: 1jtw
Elevation: 50 to 360 feet
Mean annual precipitation: 46 to 54 inches
Mean annual air temperature: 70 to 77 degrees F
Frost-free period: 350 to 365 days
Farmland classification: Not prime farmland

Map Unit Composition

Arents and similar soils: 100 percent
Estimates are based on observations, descriptions, and transects of the mapunit.

Description of Arents

Setting

Landform: Rises on marine terraces
Landform position (three-dimensional): Rise
Down-slope shape: Convex
Across-slope shape: Linear
Parent material: Altered marine deposits

Typical profile

C - 0 to 80 inches: sand

Properties and qualities

Slope: 2 to 5 percent
Depth to restrictive feature: More than 80 inches
Drainage class: Moderately well drained
Runoff class: Negligible
Capacity of the most limiting layer to transmit water (Ksat): Very high (19.98 to 50.02 in/hr)
Depth to water table: About 24 to 48 inches

Custom Soil Resource Report

Frequency of flooding: None
Frequency of ponding: None
Maximum salinity: Nonsaline to very slightly saline (0.0 to 2.0 mmhos/cm)
Sodium adsorption ratio, maximum: 4.0
Available water supply, 0 to 60 inches: Very low (about 2.4 inches)

Interpretive groups

Land capability classification (irrigated): None specified
Hydrologic Soil Group: A
Forage suitability group: Forage suitability group not assigned (G154XB999FL)
Other vegetative classification: Forage suitability group not assigned (G154XB999FL)
Hydric soil rating: No

76—Millhopper fine sand, 0 to 5 percent slopes

Map Unit Setting

National map unit symbol: 2v177
Elevation: 60 to 230 feet
Mean annual precipitation: 44 to 56 inches
Mean annual air temperature: 68 to 75 degrees F
Frost-free period: 300 to 365 days
Farmland classification: Farmland of unique importance

Map Unit Composition

Millhopper and similar soils: 85 percent
Minor components: 15 percent
Estimates are based on observations, descriptions, and transects of the mapunit.

Description of Millhopper

Setting

Landform: Knolls on marine terraces, ridges on marine terraces
Landform position (two-dimensional): Shoulder, summit
Landform position (three-dimensional): Interflue
Down-slope shape: Convex
Across-slope shape: Linear
Parent material: Sandy and loamy marine deposits

Typical profile

A - 0 to 7 inches: fine sand
E - 7 to 59 inches: fine sand
Bt - 59 to 64 inches: sandy clay loam
Btg - 64 to 80 inches: sandy clay loam

Properties and qualities

Slope: 0 to 5 percent
Depth to restrictive feature: More than 80 inches
Drainage class: Moderately well drained
Runoff class: Low
Capacity of the most limiting layer to transmit water (Ksat): Moderately high to high (0.60 to 2.00 in/hr)

Custom Soil Resource Report

Depth to water table: About 42 to 60 inches
Frequency of flooding: None
Frequency of ponding: None
Maximum salinity: Nonsaline to very slightly saline (0.0 to 2.0 mmhos/cm)
Sodium adsorption ratio, maximum: 4.0
Available water supply, 0 to 60 inches: Low (about 4.8 inches)

Interpretive groups

Land capability classification (irrigated): None specified
Land capability classification (nonirrigated): 3s
Hydrologic Soil Group: A
Forage suitability group: Sandy soils on rises, knolls, and ridges of mesic uplands (G154XB121FL)
Other vegetative classification: Sandy soils on rises, knolls, and ridges of mesic uplands (G154XB121FL), Upland Hardwood Hammock (R154XY008FL)
Hydric soil rating: No

Minor Components

Kendrick

Percent of map unit: 8 percent
Landform: Ridges on marine terraces
Landform position (two-dimensional): Shoulder
Landform position (three-dimensional): Interfluve
Down-slope shape: Convex
Across-slope shape: Linear
Other vegetative classification: Sandy over loamy soils on knolls and ridges of mesic uplands (G154XB211FL)
Hydric soil rating: No

Tavares

Percent of map unit: 5 percent
Landform: Knolls on marine terraces, ridges on marine terraces
Landform position (two-dimensional): Backslope
Landform position (three-dimensional): Interfluve
Down-slope shape: Convex
Across-slope shape: Linear
Other vegetative classification: Sandy soils on rises, knolls, and ridges of mesic uplands (G154XB121FL), Longleaf Pine-Turkey Oak Hills (R154XY002FL)
Hydric soil rating: No

Nobleton

Percent of map unit: 2 percent
Landform: Rises on marine terraces
Landform position (two-dimensional): Backslope
Landform position (three-dimensional): Interfluve
Down-slope shape: Convex
Across-slope shape: Linear
Other vegetative classification: Sandy over loamy soils on rises and knolls of mesic uplands (G154XB231FL)
Hydric soil rating: Yes

99—Water

Map Unit Composition

Water: 100 percent

Estimates are based on observations, descriptions, and transects of the mapunit.

Description of Water

Interpretive groups

Land capability classification (irrigated): None specified

Forage suitability group: Forage suitability group not assigned (G154XB999FL)

Other vegetative classification: Forage suitability group not assigned
(G154XB999FL)

Hydric soil rating: Unranked

References

- American Association of State Highway and Transportation Officials (AASHTO). 2004. Standard specifications for transportation materials and methods of sampling and testing. 24th edition.
- American Society for Testing and Materials (ASTM). 2005. Standard classification of soils for engineering purposes. ASTM Standard D2487-00.
- Cowardin, L.M., V. Carter, F.C. Golet, and E.T. LaRoe. 1979. Classification of wetlands and deep-water habitats of the United States. U.S. Fish and Wildlife Service FWS/OBS-79/31.
- Federal Register. July 13, 1994. Changes in hydric soils of the United States.
- Federal Register. September 18, 2002. Hydric soils of the United States.
- Hurt, G.W., and L.M. Vasilas, editors. Version 6.0, 2006. Field indicators of hydric soils in the United States.
- National Research Council. 1995. Wetlands: Characteristics and boundaries.
- Soil Survey Division Staff. 1993. Soil survey manual. Soil Conservation Service. U.S. Department of Agriculture Handbook 18. http://www.nrcs.usda.gov/wps/portal/nrcs/detail/national/soils/?cid=nrcs142p2_054262
- Soil Survey Staff. 1999. Soil taxonomy: A basic system of soil classification for making and interpreting soil surveys. 2nd edition. Natural Resources Conservation Service, U.S. Department of Agriculture Handbook 436. http://www.nrcs.usda.gov/wps/portal/nrcs/detail/national/soils/?cid=nrcs142p2_053577
- Soil Survey Staff. 2010. Keys to soil taxonomy. 11th edition. U.S. Department of Agriculture, Natural Resources Conservation Service. http://www.nrcs.usda.gov/wps/portal/nrcs/detail/national/soils/?cid=nrcs142p2_053580
- Tiner, R.W., Jr. 1985. Wetlands of Delaware. U.S. Fish and Wildlife Service and Delaware Department of Natural Resources and Environmental Control, Wetlands Section.
- United States Army Corps of Engineers, Environmental Laboratory. 1987. Corps of Engineers wetlands delineation manual. Waterways Experiment Station Technical Report Y-87-1.
- United States Department of Agriculture, Natural Resources Conservation Service. National forestry manual. http://www.nrcs.usda.gov/wps/portal/nrcs/detail/soils/home/?cid=nrcs142p2_053374
- United States Department of Agriculture, Natural Resources Conservation Service. National range and pasture handbook. <http://www.nrcs.usda.gov/wps/portal/nrcs/detail/national/landuse/rangepasture/?cid=stelprdb1043084>

Custom Soil Resource Report

United States Department of Agriculture, Natural Resources Conservation Service. National soil survey handbook, title 430-VI. http://www.nrcs.usda.gov/wps/portal/nrcs/detail/soils/scientists/?cid=nrcs142p2_054242

United States Department of Agriculture, Natural Resources Conservation Service. 2006. Land resource regions and major land resource areas of the United States, the Caribbean, and the Pacific Basin. U.S. Department of Agriculture Handbook 296. http://www.nrcs.usda.gov/wps/portal/nrcs/detail/national/soils/?cid=nrcs142p2_053624

United States Department of Agriculture, Soil Conservation Service. 1961. Land capability classification. U.S. Department of Agriculture Handbook 210. http://www.nrcs.usda.gov/Internet/FSE_DOCUMENTS/nrcs142p2_052290.pdf

APPENDIX F:
Correspondence

Project Name
Old Dixie Trail PD&E
from Auburndale to Haines City
FPID# 435391-1-22-01

Date of Meeting
August 5, 2020



HNTB Project #
64001

Location
GoToMeeting

Purpose of Meeting
Pre-Application Meeting

Time
2:00 pm – 3:00 pm

Participants

Dave Kramer (SWFWMD)
Al Gagne (SWFWMD)
Brent Setchell (FDOT)
Nicole Monies (FDOT)
Sergio Figueroa (FDOT)
Michelle Rutishauser (HNTB)
Brian McCarthy (HNTB)
Chris Kuzlo (HNTB)

MEETING MINUTES

1. Project Overview

- Nicole and Michelle provided an overview of the Old Dixie Trail Project Development & Environment (PD&E) Study.
 - Proposed 10-12 feet wide multiuse trail from Auburndale to Haines City (8 feet wide at specific locations).
 - Two PD&E alternatives.
 - Three proposed design/construction segments:
 - Segment 1 = Berkley Rd to Shinn Blvd (northern route from Auburndale to Lake Alfred)
 - Segment 2 = Shinn Blvd to Haines City (Lake Alfred to Haines City)
 - Segment 3 = Berkley Rd to S Buena Vista Dr (southern route from Auburndale to Lake Alfred thru Winter Haven)
- Project is in the early stage of PD&E as no preferred alternative has been selected.

2. Permit Type

- Dave stated the project will likely require an Individual Permit, but the ERP would only take into account the portions of the project that impact wetlands or floodplains.
- Dave suggested the project be submitted under one permit application and the impact area could be used in place of the “project size” since the length of the project would likely require a higher permit fee than the overall impacts.

3. Wetland Impacts

- Michelle stated that of the three proposed design/construction segments, one is showing less than 0.5 acres and the other two may have over 0.5 acres of wetland impact. Wetlands will be

minimized to the greatest extent practicable and the impacts will be evaluated using UMAM during design and will be offset using wetland mitigation.

4. Floodplain Impacts

- Brian stated that most floodplain impacts are at cross drain extensions with *de minimis* impact.
 - Dave cautioned FDOT to look at the project holistically and the potential cumulative floodplain impacts to the entire project vs looking at *de minimis* floodplain impacts individually.
 - Brian stated there are 10-15 cross drains, resulting in 0.01-0.02 acre feet, each of floodplain impact.
 - Dave stated there is no threshold for mitigation requirements for floodplain impacts necessarily, but we need to take a look at the cumulative impacts.
 - FDOT agreed that the project will be evaluated cumulatively to determine impacts.
- Brian stated there are floodplain impacts associated with wetlands in Winter Haven. Based on the Peace Creek Watershed Model, there was no rise in the floodplain with the proposed improvements.
 - Dave confirmed that was a valid way to evaluate floodplain impacts.

5. Drainage Impacts

- Dave confirmed that since this is a trail, the project is not required to meet treatment and attenuation requirements as long as there is no loss in treatment function from an existing system.

6. Haines City Burger King

- Brian stated that the existing Burger King stormwater pond will be impacted by the trail and asked if FDOT or Burger King would be the permittee.
- Brent stated that FDOT will determine the “cost to cure” Burger King’s pond as part of the right-of-way (ROW) acquisition. FDOT would financially compensate Burger King both for the ROW acquisition and for Burger King to modify their permit due to the trail impact. Burger King will apply for the permit modification.

7. Species

- Nicole asked if there are any bald eagles nest within the project.
- Michelle stated there are no active bald eagles nest within 330 or 660 feet of the project corridor.
- The project may impact sand skink suitable soils.

Potential Wetland Involvement

Alternative 1: 0.816 Acres
 Alternative 2: 1.34 Acres

Design Construction Segment 1: 0.180 Acres
 Design Construction Segment 2: 0.636 Acres
 Design Construction Segment 3: 0.701 Acres

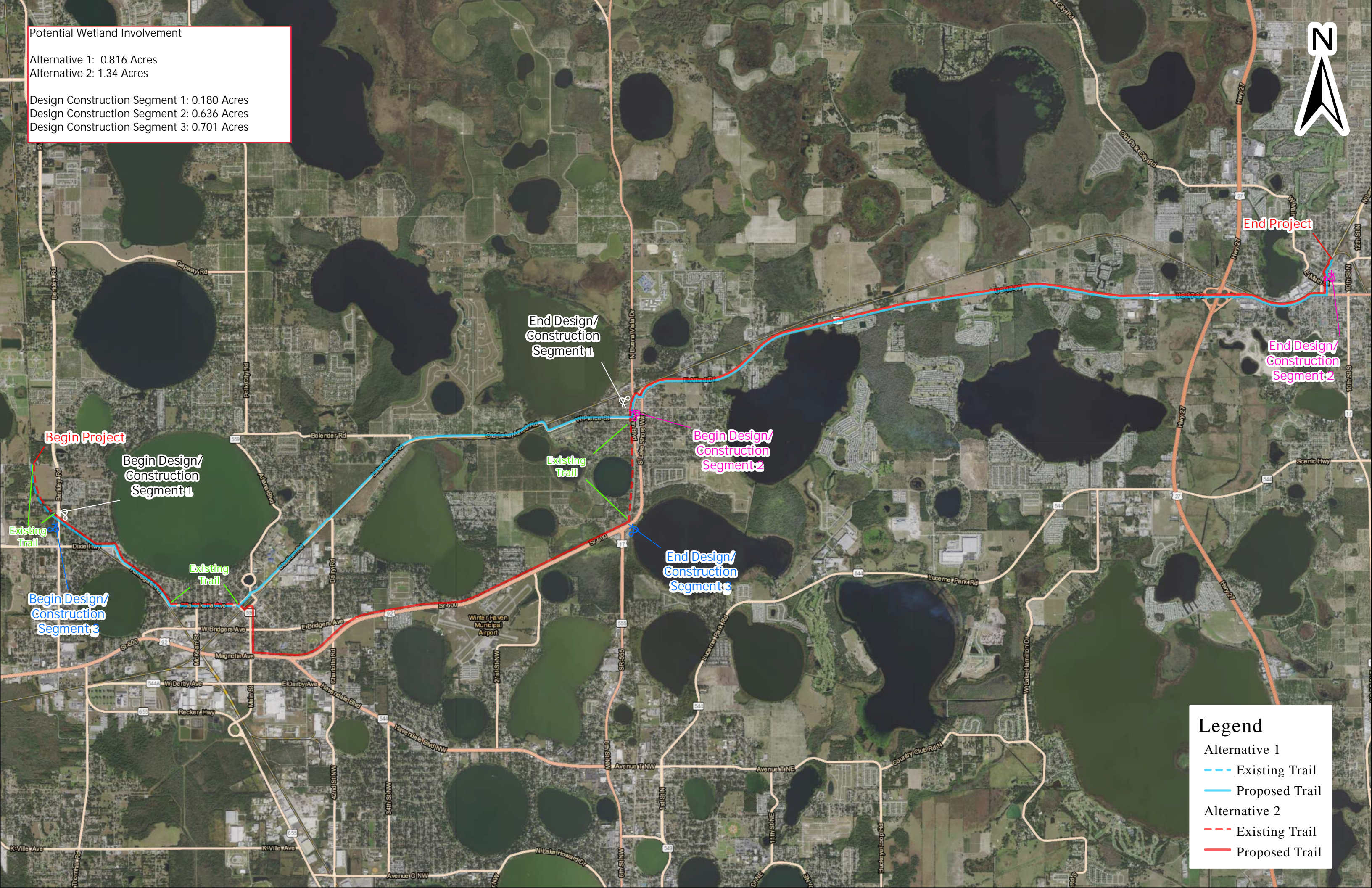

Legend

Alternative 1

- Existing Trill
- Proposed Trill

Alternative 2

- Existing Trill
- Proposed Trill